

Inhoud

Contents

Inhalt

Table des matières

Inhoud

Contents

Inhalt

Table des matières

Kwaliteitsgarantie	Quality assurance	Qualitätssicherung	Assurance qualité	
Ronde buizen gelast en naadloos	Round pipes and tubes welded and seamless	Rundrohre geschweisst und nahtlos	Tubes circulaires soudés et sans soudure	4
Machinebuizen	Hollow bars	Hohlstahl	Ebauches	6
Vierkant/Rechthoek Profielbuizen	Square/Rectangular Hollow Sections	Vierkant/Rechteck Rohre	Tubes profilés carrés / rectangulaires	19
Hoekprofiel	Angleprofiles	Winkelstahl	Cornières	23
Strip	Flat bars	Flachstahl	Plats	27
Rondstaf	Round bars	Rundstahl	Barres rondes	28
Lasbochten gelast en naadloos	Elbows welded and seamless	Rohrbögen geschweisst und nahtlos	Coudes soudés et sans soudure	31
Verloopstukken concentrisch gelast en naadloos	Reducers concentric welded and seamless	Reduzierungen concentrisch geschweisst und nahtlos	Réductions concentriques soudées et sans soudure	33
Verloopstukken excentrisch gelast en naadloos	Reducers excentric welded and seamless	Reduzierungen excentrisch geschweisst und nahtlos	Réductions excentriques soudées et sans soudure	41
T-stukken (gelijkzijdig) gelast en naadloos	Tees (equal) welded and seamless	T-Stücke (egal) geschweisst und nahtlos	Tes soudés et sans soudure (égaux)	50
T-stukken (verloop) gelast en naadloos	Tees (reducing) welded and seamless	T-Stücke (mit reduziertem Abzweig) geschweisst und nahtlos	Tes-réduits soudés et sans soudure (réducteurs)	53
Stub-ends gelast en naadloos	Stub-ends welded and seamless	Stub-ends geschweisst und nahtlos	Stub-ends soudés et sans soudure	59
Caps	Caps	Kappen	Caps	61
Lasbodems	Caps	Klöpperböden	Fonds	63
Kapbeugels/Pijpbeugels	Pipe clips/Double clips	Kappschellen/Doppelschellen	Clips/Colliers pour tubes	65
Boordringen	Pressed collars	Bördel	Collets emboutis	66
Aluminium flenzen	Aluminium flanges	Losflansche aus Aluminium	Brides en aluminium	68
Elektrolytisch verzinkte flenzen st. 37.2	Electrolytic galvanised flanges st. 37.2	Elektrolytisch galvanisierte Flansche st. 37.2	Brides galvanisée électrolytique st. 37.2	71
				73

Geperste overschuifflenzen geel verchromd st. 37.2	Pressed loose flanges yellow passivated st. 37.2	Gepresste Losflansche gelb passiviert st. 37.2	Brides tournantes embouties bichromaté jaun st. 37.2	73
Overschuifflenzen EN 1092-1 type 02 PN 10	Slip-on flanges EN 1092-1 type 02 PN 10	Überschiebflansche EN 1092-1 type 02 PN 10	Brides tournantes EN 1092-1 type 02 PN 10	75
Draadflenzen EN 1092-1 type 13 PN 10/16	Threaded flanges EN 1092-1 type 13 PN 10/16	Gewindeflansche EN 1092-1 type 13 PN 10/16	Brides à visser EN 1092-1 type 13 PN 10/16	76
Blindflenzen EN 1092-1 type 05 PN 10/16 PN 40	Blindflanges EN 1092-1 type 05 PN 10/16 PN 40	Blindflansche EN 1092-1 type 05 PN 10/16 PN 40	Brides pleines EN 1092-1 type 05 PN 10/16 PN 40	77
Vlakke lasflenzen EN 1092-1 type 01 PN 10	Flat welding flanges EN 1092-1 type 01 PN 10	Glatte Flansche EN 1092-1 type 01 PN 10	Brides plates à souder EN 1092-1 type 01 PN 10	78
Voorlasflenzen EN 1092-1 type 11, PN 10 PN 25/40 PN 64/100	Welding neck flanges EN 1092-1 type 11, PN 10 PN 25/40 PN 64/100	Vorschweisflansche EN 1092-1 type 11, PN 10 PN 25/40 PN 64/100	Brides à collerette EN 1092-1 type 11, PN 10 PN 25/40 PN 64/100	80
Welding neck flenzen 150 / 300 / 600 / 1500 lbs	Welding neck flanges 150 / 300 / 600 / 1500 lbs	Vorschweisflansche 150 / 300 / 600 / 1500 lbs	Brides à collerette 150 / 300 / 600 / 1500 lbs	84
Slip-on flenzen 150 / 300 / 600 lbs	Slip-on flanges 150 / 300 / 600 lbs	Überschiebflansche 150 / 300 / 600 lbs	Brides à emmancher 150 / 300 / 600 lbs	89
Draadflenzen 150 lbs	Threaded flanges 150 lbs	Gewindeflansche 150 lbs	Brides à visser 150 lbs	91
Blindflenzen 150 / 300 / 600 lbs	Blind flanges 150 / 300 / 600 lbs	Blindflansche 150 / 300 / 600 lbs	Brides pleines 150 / 300 / 600 lbs	92
Lap joint flenzen 150 / 300 lbs	Lap joint flanges 150 / 300 lbs	Lap joint flansche 150 / 300 lbs	Brides tournantes 150 / 300 lbs	94
Socket Weld flenzen 150 / 300 lbs	Socket Weld flanges 150 / 300 lbs	Socket Weld flansche 150 / 300 lbs	Brides à emboîter 150 / 300 lbs	95
Naadloze pijpnippels	Seamless pipenipples	Nahtlose Rohrrippels	Nipple hors tubes sans soudure	96
Gesmede fittings 3000 / 6000 lbs	Forged fittings 3000 / 6000 lbs	Geschmiedene Fittings 3000 / 6000 lbs	Raccords forgés 3000 / 6000 lbs	99
Draadfittings BSP	Threaded fittings BSP	Gewindefittings BSP	Raccords filetés BSP	107
Snijringkoppelingen hoge druk	Bite-ring couplings high pressure	Scheidringverschraubungen Hohe Druck	Accessoires à bague coupante haute pression	122

Technische bijlagen	Technical data	Technische Daten	Données techniques	
ASTM/ASME/MSS/DIN normen	ASTM/ASME/MSS/DIN standards	ASTM/ASME/MSS/DIN Normierungen	Normes ASTM/ASME/MSS/DIN	126
ANSI afmetingen en gewichten	ANSI dimensions and weights	ANSI Abmessungen und Gewichte	Dimensions et poids ANSI	134
BWG en SWG afmetingen en gewichten	BWG and SWG dimensions and weights	BWG und SWG-Abmessungen und Gewichte	Dimensions et poids BWG et SWG	138
Vergelijkingstabel roestvaststaal	Comparison table different names of stainless steel	Vergleichstabelle Edelstahlsorten	Tableau comparatif des différentes appellations d'acier inoxydable	139
Mechanische eigenschappen	Mechanical properties	Mechanische Eigenschaften	Propriétés mécaniques	143
Toleranties ASTM/DIN/ISO	Tolerances ASTM/DIN/ISO	Toleranzen ASTM/DIN/ISO	Tolérances ASTM/DIN/ISO	145
Tabel voor druk en temperatuur	Table for pressure and temperature	Druck-Temperatur tabelle	Tableau de pression et de température	147
Austenitisch roestvaststaal 304(L) en 316(L)	Austenitic stainless steel 304(L) and 316(L)	Austenitischer, nichtrostender Stahl 304(L) und 316(L)	Acier inoxydable austénitique 304(L) et 316(L)	169
Toepassingsgebieden roestvaststaal	Application areas stainless steel	Anwendungsbereiche nichtrostender Stahlsorten	Champs d'applications d'acier inoxydable	171
Corrosie	Corrosion	Korrosion	Corrosion	175
Beproevingen	Testing	Prüfungen	Tests	183
Keuringsdocumenten	Inspection documents	Prüfbescheinigungen	Documents de contrôle	187

Kwaliteitsgarantie

Quality assurance

Qualitätssicherung

Assurance qualité

Kwaliteitsgarantie

Quality assurance

Qualitätssicherung

Assurance qualité

Kwaliteitsgarantie
Quality assurance
Qualitätssicherung
Assurance qualité

Kwaliteitsgarantie

Quality assurance

Qualitätssicherung

Assurance qualité

Gelaste buizen

Welded tubes

Geschweisste Rohre

Tubes soudés

Spec. 001

Langsnaadgelaste roestvaststalen buizen volgens EN 10217-7 "Prüfklasse 1", gegloeid en met toleranties volgens EN ISO 1127 , D3/T3.

Keuringsrapport volgens EN 10204/3.1.

Buizen aanvullend getest op interkristallijne corrosie volgens EN ISO 3651-2 en afgeperst en/of wervelstroom beproefd en PMI.

Buizen doorlopend gemerkt. Lengten van ca. 6 meter.

Longitudinally welded stainless steel tubes acc. to EN 10217-7 testclass 1, annealed and with tolerances acc. to EN ISO 1127 , D3/T3. Inspection certificate as per EN 10204/3.1.

Tubes additionally tested on intergranular corrosion as per EN ISO 3651-2 and hydrostatically and/or Eddy current tested and PMI.

Tubes continuously marked. Lengths of ca. 6 metres.

Längsnahtgeschweisste Edelstahlrohre nach EN 10217-7 Prüfklasse 1, gegläht und mit Toleranzen nach EN ISO 1127 , D3/T3.

Abnahmeprüfzeugnis nach EN 10204/3.1.

Rohre zusätzlich geprüft auf interkristalline Korrosion nach EN ISO 3651-2 und Kaltwasserprobe und/oder Wirbelstrom geprüft und PMI.

Rohre fortlaufend markiert. Längen von ca. 6 Meter.

Tubes soudés longitudinalement en acier inoxydable, conformes à la classe de test 1 de la norme EN 10217-7, recuits et avec des tolérances conformes aux normes EN ISO 1127, D3/T3.

Certificat d'inspection selon la norme EN 10204/3.1.

Tubes testés pour leur corrosion intergranulaire conformément à la norme EN ISO 3651-2 et soumis à un test hydrostatique et/ou par courant de Foucault et PMI.

Tubes marqués sans interruption. Longueur de 6 mètres environ.

Spec. 002

Langsnaadgelaste roestvaststalen buizen volgens EN 10296-2, niet gegloeid en met toleranties volgens EN ISO 1127, D3/T3. Keuringsrapport volgens EN 10204/3.1.

Buizen aanvullend getest op interkristallijne corrosie volgens EN ISO 3651-2 en afgeperst en/of wervelstroom beproefd.

Buizen doorlopend gemerkt. Lengten van ca. 6 meter.

Longitudinally welded stainless steel tubes acc. to EN 10296-2, not annealed and with tolerances acc. to EN ISO 1127, D3/T3.

Inspection certificate as per EN 10204/3.1.

Tubes additionally tested on intergranular corrosion as per EN ISO 3651-2 and hydrostatically and/or Eddy current tested.

Tubes continuously marked. Lengths of ca. 6 metres.

Längsnahtgeschweisste Edelstahlrohre nach EN 10296-2 nicht gegläht und mit Toleranzen nach EN ISO 1127 , D3/T3.

Abnahmeprüfzeugnis nach EN 10204/3.1.

Rohre zusätzlich geprüft auf interkristalline Korrosion nach EN ISO 3651-2 und Kaltwasserprobe und/oder Wirbelstrom geprüft.

Rohre fortlaufend markiert. Längen von ca. 6 Meter.

Tubes soudés longitudinalement en acier inoxydable, conformes à la norme EN 10296-2, non recuits et avec des tolérances conformes aux normes EN ISO 1127, D3/T3.

Certificat d'inspection selon la norme EN 10204/3.1.

Tubes testés également pour leur corrosion intergranulaire conformément à la norme EN ISO 3651-2 et soumis à un test par hydrostatique et/ou courant de Foucault.

Tubes marqués sans interruption. Longueur de 6 mètres environ.

Spec. 003

Langsnaadgelaste roestvaststalen buizen voor decoratie en constructie, licht geborsteld, niet gegloeid en met toleranties volgens EN ISO 1127, D3/T3. Lengten van ca. 6 meter.

Longitudinally welded stainless steel tubes for structures, lightlybrushed, not annealed and with tolerances acc. to EN ISO 1127, D3/T3. Lengths of ca. 6 metres.

Längsnahtgeschweisste Edelstahlrohre für den Stahlbau, gebürstet, nicht gegläht und mit Toleranzen nach EN ISO 1127 D3/T3. Längen von ca. 6 Meter.

Tubes soudés longitudinalement en acier inoxydable pour structures, légèrement brossés, non recuits, avec des tolérances conformes aux normes EN ISO 1127, D3/T3. Longueur de 6 mètres environ.

Spec. 004

Langsnaadgelaste roestvaststalen buizen volgens ASTM A312/A999.

Buizen gecertificeerd en gemerkt. Keuringsrapport volgens EN 10204/3.1.

Buizen aanvullend getest op interkristallijne corrosie volgens ASTM A262 pr. E, PMI, afgeperst en/of wervelstroom beproefd.

Buizen doorlopend gemerkt. Buizen met gladde einden in lengten van 6 ca. meter.

Longitudinally welded stainless steel tubes acc. to ASTM A312/A999.

Tubes certified and marked. Inspection certificate as per EN 10204/3.1.

Tubes additionally tested on intergranular corrosion as per ASTM A262 pr. E, PMI, hydrostatically and/or Eddy current tested.

Tubes continuously marked. Tubes with plain ends in lengths of ca 6 metres.

Längsnahtgeschweisste Edelstahlrohre nach ASTM A312/A999.

Rohre zertifiziert und markiert. Abnahmeprüfzeugnis nach EN 10204/3.1.

Rohre zusätzlich geprüft auf Interkristalline Korrosion nach ASTM A262 pr.E, Verwechslungsprüfung, Kaltwasserprobe und/oder Wirbelstrom geprüft.

Rohre fortlaufend markiert. Rohre mit glatten Enden in Längen von ca. 6 Meter.

Tubes soudés longitudinalement en acier inoxydable conformes à la norme ASTM A312/A999.

Tubes certifiés et marqués. Certificat d'inspection selon la norme EN 10204/3.1.

Tubes testés également pour leur corrosion intergranulaire conformément à la norme ASTM A262 pr. E. Test PMI et test hydrostatique et/ou par courant de Foucault.

Tubes marqués sans interruption. Tubes avec extrémités lisses d'une longueur de 6 mètres.

Spec. 005

Langsnaadgelaste roestvaststalen buizen, ongegloeid, volgens ASTM A778 of A312/A999-HTO.

Buizen gecertificeerd en gemerkt. Keuringsrapport volgens EN 10204/3.1.

Buizen aanvullend getest op interkristallijne corrosie volgens ASTM A262 pr. E, PMI, afgeperst en/of wervelstroom beproefd.

Buizen doorlopend gemerkt. Buizen met gladde einden in lengten van ca. 6 meter.

Longitudinally welded stainless steel tubes, not annealed, acc. to ASTM A778 or A312/A999-HTO.

Tubes certified and marked. Inspection certificate as per EN 10204/3.1.

Tubes additionally tested on intergranular corrosion as per ASTM A262 pr. E, PMI, hydrostatically and/or Eddy current tested.

Tubes continuously marked. Tubes with plain ends in lengths of ca. 6 metres.

Längsnahtgeschweisste Edelstahlrohre nach ASTM A778 oder A312/A999-HTO, nicht geglüht..

Rohre zertifiziert und markiert. Abnahmeprüfzeugnis nach EN 10204/3.1.

Rohre zusätzlich geprüft auf interkristalline Korrosion nach ASTM A262 pr. E, Verwechslungsprüfung, Kaltwasserprobe und/oder Wirbelstrom geprüft.

Rohre fortlaufend markiert. Rohre mit glatten Enden in Längen von 6 Meter.

Tubes soudés longitudinalement en acier inoxydable, non recuits et conformes à la norme ASTM A778 ou A312/A999-HTO.

Tubes certifiés et marqués. Certificat d'inspection selon la norme EN 10204/3.1.

Tubes testés également pour leur corrosion intergranulaire conformément à la norme ASTM A262 pr. E. Test PMI et test hydrostatique et/ou par courant de Foucault.

Tubes marqués sans interruption. Tubes avec extrémités lisses d'une longueur de 6 mètres.

Spec. 006

Langsnaadgelaste roestvaststalen buizen voor de zuivelindustrie volgens DIN 11850, gegloeid.

Keuringsrapport volgens EN 10204/3.1.

Buizen aanvullend getest op interkristallijne corrosie volgens EN ISO 3651-2 en wervelstroom beproefd.

Buizen doorlopend gemerkt. Lengten van ca. 6 meter.

Longitudinally welded stainless steel dairy-tubes acc. to DIN 11850, annealed.

Inspection certificate as per EN 10204/3.1.

Tubes additionally tested on intergranular corrosion as per EN ISO 3651-2 and Eddy current tested.

Tubes continuously marked. Lengths of ca. 6 metres.

Längsnahtgeschweisste Edelstahlrohre für den Getränke- und Lebensmittelindustrie nach DIN 11850, gegläht.

Abnahmeprüfzeugnis nach EN 10204/3.1.

Rohre zusätzlich geprüft auf interkristalline Korrosion nach EN ISO 3651-2 und Wirbelstrom geprüft.

Rohre fortlaufend markiert. Längen von ca. 6 Meter.

Tubes soudés longitudinalement en acier inoxydable pour laiterie, recuits et conformes à la norme DIN 11850.

Certificat d'inspection selon la norme EN 10204/3.1.

Tubes testés également pour leur corrosion intergranulaire conformément à la norme EN ISO 3651-2 et soumis à un test par courant de Foucault.

Tubes marqués sans interruption. Longueur de 6 mètres environ.

Naadloze buizen Seamless tubes Nahtlose Rohre Tubes sans soudure

Spec. 001

Naadloze roestvaststalen buizen volgens ASME SA312/A999, ASTM A312/A999.

Buizen tweevoudig gecertificeerd. Keuringsrapport volgens EN 10204/3.1.

Buizen aanvullend getest op interkristallijne corrosie volgens ASTM A262 pr. E en PMI d.m.v. spectrograph.

Hardheid HRC 22 max. volgens NACE MR01-75 laatste uitgave.

Buizen met wanddikte boven 10 mm beproefd op kerftaaiheid bij kamertemperatuur.

Buizen met gladde einden in lengten van 4,5 - 6,5 meter en doorlopend gemerkt.

Seamless stainless steel pipes acc. to ASME SA312/A999, ASTM A312/A999.

Tubes dual certified. Inspection certificate as per EN 10204/3.1.

Tubes additionally tested on intergranular corrosion as per ASTM A262 pr. E and PMI by spectrograph.

Hardness HRC 22 max. as per NACE MR01-75 latest edition.

Tubes with wallthickness over 10 mm impact tested at room temperature.

Tubes with plain ends in random lengths of 4,5 - 6,5 metres and continuously marked.

Nahtlose Edeltstahlrohre nach ASME SA312/A999, ASTM A312/A999.

Rohre zweifach zertifiziert. Abnahmeprüfzeugnis nach EN 10204/3.1.

Rohre zusätzlich geprüft auf interkristalline Korrosion nach ASTM A262 pr. E und Verwechslungsprüfung durch Spectrograph.

Härte HRC max. 22 nach NACE MR01-75 letzte Ausgabe.

Rohre mit Wanddicke grösser 10 mm auf Kerbschlagzähigkeit geprüft bei 20° C.

Rohre mit glatten Enden in Längen von 4,5 - 6,5 meter fortlaufend markiert.

Tubes sans soudure en acier inoxydable conformes aux normes ASME SA312/A999, ASTM A312/A999.

Certification double. Certificat d'inspection selon la norme EN 10204/3.1.

Tubes testés également pour leur corrosion intergranulaire conformément à la norme ASTM A262 pr. E. Test PMI par spectrographie.

Dureté HRC 22 max. conformément à la norme NACE MR01-75 (dernière édition).

Tubes d'une épaisseur de paroi de plus de 10 mm soumis à un test d'impact à température ambiante.

Tubes marqués sans interruption avec extrémités lisses d'une longueur de 4,5 à 6,5 mètres.

Spec. 002

Naadloze roestvaststalen buizen volgens ASTM A269/A213 en A1016.

Buizen tweevoudig gecertificeerd. Keuringsrapport volgens EN 10204/3.1.

Buizen aanvullend getest op interkristallijne corrosie volgens ASTM A262 pr. E en PMI d.m.v. spectrograph.

Hardheid 90 HRB en waar mogelijk 80 HRB max.

Lengten van 4,5 - 6,5 meter.

Seamless stainless steel pipes acc. to ASTM 269/213 and A1016.

Tubes dual certified. Inspection certificate as per EN 10204/3.1.

Tubes additionally tested on intergranular corrosion as per ASTM A262 pr. E and PMI by spectrograph.

Hardness 90 HRB max., where possible 80 HRB max.
Random lengths of 4,5 - 6,5 metres.

Nahtlose Edelstahlrohre nach ASTM A269/A213 und A1016.
Rohre zweifach zertifiziert. Abnahmeprüfzeugnis nach EN 10204/3.1.
Rohre zusätzlich geprüft auf interkristalline Korrosion nach ASTM A262 pr. E und Verwechslungsprüfung durch Spectrograph.
Härte 90 HRB max., wenn möglich 80 HRB max.
Längen von 4,5 - 6,5 Meter.

Tubes sans soudure en acier inoxydable conformes aux normes ASTM 269/213 and A1016.
Double Certification. Certificat d'inspection selon la norme EN 10204/3.1.
Tubes testés également pour leur corrosion intergranulaire conformément à la norme ASTM A262 pr. E. Test PMI par spectrographie.
Dureté : 90 HRB max., si possible 80 HRB max.
Longueur de 4,5 à 6,5 mètres.

**Buizen
naadloos/gelast**
**Tubes
seamless/welded**
**Rohre
nahtlos/geschweisst**
**Tubes soudés/
sans soudure**

Buizen naadloos/gelast
Tubes seamless/welded
Rohre nahtlos/geschweisst
Tubes soudés/sans soudure

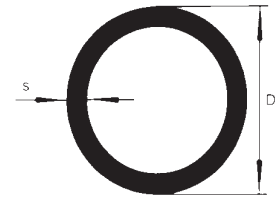

Omschrijving op pagina 6-11
Description on page 6-11
Umschreibung auf Seite 6-11
Description à la page 6-11

- = ook geslepen K 320
- = also ground K 320
- = auch geschliffen K 320
- = aussi polis G 320

Afmeting Size Abmessung Dimension		Afmeting Size Abmessung Dimension		Gewicht Weight Gewicht Poids	304 (1.4301)	304L (1.4306) (1.4307)	316L (1.4404) (1.4571)	304(L) (1.4306) (1.4307) (1.4301)	321(H) (1.4541)	316(L) (1.4404) (1.4571)
D mm	s mm	D inch	s inch / sch	± Kg/m	gelast welded geschw. soudés	gelast welded geschw. soudés	gelast welded geschw. soudés	naadloos seamless nahtlos sans soudure	naadloos seamless nahtlos sans soudure	naadloos seamless nahtlos sans soudure
6,00	1,00			0,13	X		X	X		X
6,00	1,50			0,17						X
6,35	0,71	1/4"	.028"	0,10						X
6,35	0,91	1/4"	.036"	0,12				X		X
6,35	1,22	1/4"	.048"	0,16				X		X
6,35	1,63	1/4"	.064"	0,19					X	X
8,00	1,00			0,18	X		X	X	X	X
8,00	1,50			0,24				X	X	X
8,00	2,00			0,30				X		X
9,53	0,91	3/8"	.036"	0,20				X		X
9,53	1,22	3/8"	.048"	0,25				X	X	X
9,53	1,63	3/8"	.064"	0,32				X		X
10,00	1,00			0,23	X		X	X	X	X
10,00	1,50			0,32	X		X	X	X	X
10,00	2,00			0,40				X		X
10,20	2,00	1/8"	GAS	0,41				X		X
12,00	1,00			0,28	X		X	X	X	X
12,00	1,50			0,39	X	X	X	X	X	X
12,00	2,00			0,50				X	X	X
12,70	0,91	1/2"	.036"	0,27				X	X	X
12,70	1,22	1/2"	.048"	0,35				X		X
12,70	1,63	1/2"	.064"	0,45				X		X
12,70	2,00	1/2"	.079"	0,54						X
12,70	2,11	1/2"	.083"	0,54						X
13,00	1,00			0,30	X					
13,00	1,50			0,43	X			X		
13,72	1,65	1/4"	Sch 10 S	0,50				X		X
13,72	2,24	1/4"	Sch 40 S STD	0,65		X	X	X		X
13,72	3,02	1/4"	Sch 80 S XS	0,81				X	X	X
14,00	1,00			0,33	X		X		X	X
14,00	1,50			0,47	X					X
14,00	2,00			0,60	X		X	X	X	X
14,00	3,00			0,83						X
15,00	1,00			0,35	X		X	X		X
15,00	1,50			0,51	X		X	X	X	X
15,00	2,00			0,65	X		X	X	X	X
15,88	1,63	5/8"	.064"	0,58				X		X
16,00	1,00			0,38	X		X	X		X
16,00	1,50			0,55	X		X	X		X
16,00	2,00			0,70	X		X	X	X	X
16,00	3,00			0,98				X	X	X
17,15	1,65	3/8"	Sch 10 S	0,64						X
17,15	2,31	3/8"	Sch 40 S STD	0,86				X	X	X
17,15	3,20	3/8"	Sch 80 S XS	1,12				X	X	X
17,20	1,60			0,63	X	X	X			X

**Buizen
naadloos/gelast**
 **Tubes
seamless/welded**
**Rohre
nahtlos/geschweisst**
 **Tubes soudés/
sans soudure**

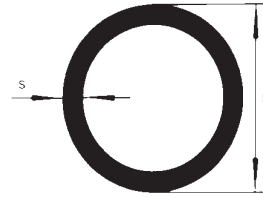

Omschrijving op pagina 6-11
Description on page 6-11
Umschreibung auf Seite 6-11
Description à la page 6-11

- = ook geslepen K 320
- = also ground K 320
- = auch geschliffen K 320
- = aussi polis G 320

Afmeting Size Abmessung Dimension		Afmeting Size Abmessung Dimension		Gewicht Weight Gewicht Poids	304 (1.4301)	304L (1.4306) (1.4307)	316L (1.4404) (1.4571)	304(L) (1.4306) (1.4307) (1.4301)	321(H) (1.4541)	316(L) (1.4404) (1.4571)
D mm	s mm	D inch	s inch / sch	± Kg/m	gelast welded geschw. soudés	gelast welded geschw. soudés	gelast welded geschw. soudés	naadloos seamless nahtlos sans soudure	naadloos seamless nahtlos sans soudure	naadloos seamless nahtlos sans soudure
17,20	2,00			0,76	X		X			
17,20	2,30	3/8"	GAS	0,87	X	X	X		X	
18,00	1,00			0,43	X		X	X		
18,00	1,50			0,62	X		X	X	X	X
18,00	2,00			0,80		X		X	X	X
18,00	2,50			0,97						X
18,00	4,00			1,40					X	X
19,00	1,25			0,56	X	X				
19,00	1,50			0,64	X		X			
19,05	0,91	3/4"	.036"	0,41						X
19,05	1,22	3/4"	.048"	0,54						X
19,05	1,63	3/4"	.064"	0,72						X
19,05	2,11	3/4"	.083"	0,89				X		X
19,05	2,11	3/4"	.109"	0,90				X		
20,00	1,00			0,48	X		X			X
20,00	1,50			0,70	X■		X	X		X
20,00	2,00			0,90	X		X	X	X	X
20,00	2,50			1,10					X	X
20,00	3,00			1,28					X	X
21,30	1,60			0,79	X	X	X			X
21,30	2,00			0,97	X	X	X		X	X
21,30	2,60	1/2"	GAS	1,22	X	X	X		X	
21,34	2,11	1/2"	Sch 10 S	1,02		X	X	X		X
21,34	2,77	1/2"	Sch 40 S STD	1,29		X	X	X	X	X
21,34	3,73	1/2"	Sch 80 S XS	1,65				X	X	X
21,34	4,78	1/2"	Sch 160	1,98				X	X	X
22,00	1,00			0,53	X			X		
22,00	1,50			0,77	X■		X	X		X
22,00	2,00			1,00	X		X	X		X
23,00	1,50			0,80	X		X			X
25,00	1,00			0,60	X■		X			
25,00	1,25			0,72	X					
25,00	1,50			0,88	X	X	X	X		X
25,00	2,00			1,15	X■	X	X	X	X	X
25,00	2,50			1,41	X	X	X	X		X
25,00	3,00			1,65	X			X	X	X
25,00	4,00			2,10				X	X	X
25,40	1,25			0,76	X■		X			
25,40	1,63	1"	.064"	0,97				X		X
25,40	1,65			0,88			X			
25,40	2,11	1"	.083"	1,23						X
26,67	2,11	3/4"	Sch 10 S	1,30		X	X	X		X
26,67	2,87	3/4"	Sch 40 S STD	1,71		X	X	X	X	X
26,67	3,91	3/4"	Sch 80 S XS	2,23				X	X	X
26,67	5,53	3/4"	Sch 160	2,93				X	X	X

**Buizen
naadloos/gelast**

**Tubes
seamless/welded**

**Rohre
nahtlos/geschweisst**

**Tubes soudés/
sans soudure**

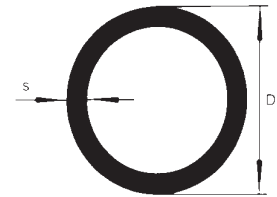

Omschrijving op pagina 6-11
Description on page 6-11
Umschreibung auf Seite 6-11
Description à la page 6-11

- = ook geslepen K 320
- = also ground K 320
- = auch geschliffen K 320
- = aussi polis G 320

Afmeting Size Abmessung Dimension		Afmeting Size Abmessung Dimension		Gewicht Weight Gewicht Poids	304 (1.4301)	304L (1.4306) (1.4307)	316L (1.4404) (1.4571)	304(L) (1.4306) (1.4307) (1.4301)	321(H) (1.4541)	316(L) (1.4404) (1.4571)
D mm	s mm	D inch	s inch / sch	± Kg/m	gelast welded geschw. soudés	gelast welded geschw. soudés	gelast welded geschw. soudés	naadloos seamless nahtlos sans soudure	naadloos seamless nahtlos sans soudure	naadloos seamless nahtlos sans soudure
26,90	1,60			1,01	X	X	X			
26,90	2,00			1,25	X	X	X	X		X
26,90	2,60	3/4"	GAS	1,58	X■	X	X			
28,00	1,00			0,67	X■		X			X
28,00	1,50			1,00	X■		X	X	X	X
28,00	2,00			1,30	X■		X	X		X
28,00	2,50			1,60				X		X
28,00	3,00			1,88						X
30,00	1,00			0,73	X					
30,00	1,50			1,07	X		X			X
30,00	2,00			1,40	X	X	X	X	X	X
30,00	2,50			1,72	X		X	X		X
30,00	3,00			2,02	X			X		X
30,00	4,00			2,60				X		X
30,00	5,00			3,13				X		X
31,80	1,20			0,96	X■					
32,00	1,50			1,15	X		X			
32,00	2,00			1,50	X		X			X
32,00	3,00			2,18				X		X
33,00	1,50			1,18	X					
33,40	2,77	1"	Sch 10 S	2,13		X	X	X	X	X
33,40	3,38	1"	Sch 40 S STD	2,54		X	X	X	X	X
33,40	4,55	1"	Sch 80 S XS	3,29				X	X	X
33,40	6,35	1"	Sch 160	4,31				X	X	X
33,40	9,09	1"	XXS	5,54				X		X
33,70	1,60			1,29	X	X	X			
33,70	2,00			1,59	X	X	X			X
33,70	2,60			2,03	X	X	X	X	X	X
33,70	3,20	1"	GAS	2,44	X	X	X	X		X
34,00	1,00			0,83	X					
34,00	1,50			1,22	X		X			
35,00	1,50			1,26	X	X	X			X
35,00	2,00			1,65	X	X	X	X		X
35,00	2,50			2,03	X	X		X	X	
35,00	3,00			2,40	X					X
38,00	3,00			2,63				X		X
38,00	4,00			3,41				X		X
38,00	5,00			4,13					X	X
38,10	1,20			1,15	X					
38,10	1,25			1,15	X■					
38,10	1,50			1,37	X■	X	X			
38,10	2,00			1,80	X■	X	X■			
38,10	2,50			2,22	X	X	X			
38,10	3,00			2,63	X		X			

**Buizen
naadloos/gelast**
 **Tubes
seamless/welded**
**Rohre
nahtlos/geschweisst**
 **Tubes soudés/
sans soudure**

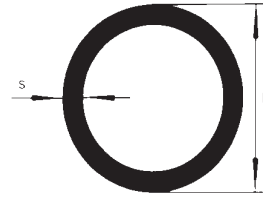

Omschrijving op pagina 6-11
Description on page 6-11
Umschreibung auf Seite 6-11
Description à la page 6-11

- = ook geslepen K 320
- = also ground K 320
- = auch geschliffen K 320
- = aussi polis G 320

Afmeting Size Abmessung Dimension		Afmeting Size Abmessung Dimension		Gewicht Weight Gewicht Poids	304 (1.4301)	304L (1.4306) (1.4307)	316L (1.4404) (1.4571)	304(L) (1.4306) (1.4307) (1.4301)	321(H) (1.4541)	316(L) (1.4404) (1.4571)
D mm	s mm	D inch	s inch / sch	± Kg/m	gelast welded geschw. soudés	gelast welded geschw. soudés	gelast welded geschw. soudés	naadloos seamless nahtlos sans soudure	naadloos seamless nahtlos sans soudure	naadloos seamless nahtlos sans soudure
40,00	1,00			0,98	X■	X	X			
40,00	1,50			1,45	X■	X	X■			
40,00	2,00			1,90	X	X	X	X	X	
40,00	2,50			2,35	X					X
40,00	3,00			2,78	X			X		X
40,00	5,00			4,38				X		X
42,00	3,00			2,93					X	X
42,16	2,77	1.1/4"	Sch 10 S	2,73		X	X	X		X
42,16	3,56	1.1/4"	Sch 40 S STD	3,44		X	X	X	X	X
42,16	4,85	1.1/4"	Sch 80 S XS	4,53				X	X	X
42,16	6,35	1.1/4"	Sch 160	5,69				X	X	X
42,40	1,60			1,63	X	X	X			
42,40	2,00			2,02	X	X	X			X
42,40	2,60			2,59	X		X	X		X
42,40	3,20	1.1/4"	GAS	3,14	X		X			X
43,00	1,50			1,56	X					
44,50	1,50			1,62	X					
44,50	2,00			2,13	X	X	X			X
48,26	2,77	1.1/2"	Sch 10S	3,15		X	X	X	X	X
48,26	3,68	1.1/2"	Sch 40 S STD	4,12		X	X	X	X	X
48,26	5,08	1.1/2"	Sch 80 S XS	5,49				X	X	X
48,26	7,14	1.1/2"	Sch 160	7,35				X	X	X
48,30	1,60			1,87	X	X	X			
48,30	2,00			2,32	X	X	X			X
48,30	2,60			2,97	X	X	X	X	X	X
48,30	3,20	1.1/2"	GAS	3,61	X	X	X			
50,00	1,50			1,82	X					
50,00	2,00			2,40	X		X	X		X
50,00	5,00			5,63				X		X
50,80	1,50			1,85	X■		X			
50,80	1,65			2,03			X			
50,80	2,00			2,44	X		X			
50,80	2,50			3,02	X	X	X			
50,80	3,00			3,59	X					
52,00	1,00			1,28	X					
52,00	1,50			1,90	X		X			
53,00	1,50			1,93	X		X			
54,00	2,00			2,60	X		X	X		X
57,00	1,50			2,08	X					
57,00	2,00			2,75	X		X	X	X	X
57,00	3,00			4,06	X		X			
60,00	5,00			6,89				X		X
60,30	1,60			2,35	X	X	X			
60,30	2,00			2,92	X	X	X	X		X

**Buizen
naadloos/gelast**

**Tubes
seamless/welded**

**Rohre
nahtlos/geschweisst**

**Tubes soudés/
sans soudure**

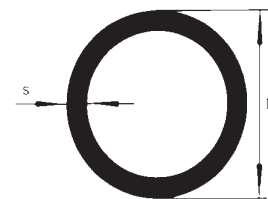

Omschrijving op pagina 6-11
Description on page 6-11
Umschreibung auf Seite 6-11
Description à la page 6-11

- = ook geslepen K 320
- = also ground K 320
- = auch geschliffen K 320
- = aussi polis G 320

Afmeting Size Abmessung Dimension		Afmeting Size Abmessung Dimension		Gewicht Weight Gewicht Poids	304 (1.4301)	304L (1.4306) (1.4307)	316L (1.4404) (1.4571)	304(L) (1.4306) (1.4307) (1.4301)	321(H) (1.4541)	316(L) (1.4404) (1.4571)
D mm	s mm	D inch	s inch / sch	± Kg/m	gelast welded geschw. soudés	gelast welded geschw. soudés	gelast welded geschw. soudés	naadloos seamless nahtlos sans soudure	naadloos seamless nahtlos sans soudure	naadloos seamless nahtlos sans soudure
60,30	2,60			3,76	X	X	X			X
60,30	3,00			4,30	X	X	X			
60,30	3,60	2"	GAS	5,11	X	X	X	X		X
60,33	1,65	2"	Sch 5 S	2,42		X	X			
60,33	2,77	2"	Sch 10 S	3,99		X	X	X	X	X
60,33	3,91	2"	Sch 40 S STD	5,52		X	X	X	X	X
60,33	5,54	2"	Sch 80 S XS	7,60				X	X	X
60,33	8,74	2"	Sch 160	11,26				X	X	X
60,33	11,07	2"	XXS	13,65				X	X	X
63,50	1,50			2,33	X■		X			
63,50	2,00			3,08	X		X			
63,50	2,60			3,97	X					X
70,00	2,00			3,40	X		X			X
70,00	3,00			5,03	X		X			
70,00	5,00			8,14				X		X
73,03	3,05	2.1/2"	Sch 10 S	5,34		X	X	X		X
73,03	5,16	2.1/2"	Sch 40 S STD	8,77		X	X	X	X	X
73,03	7,01	2.1/2"	Sch 80 S XS	11,60				X		X
76,10	1,50			2,80	X■		X			
76,10	2,00			3,71	X	X	X			
76,10	2,60			4,79	X		X			
76,10	3,00			5,49	X	X	X			
76,10	3,60	2.1/2"	GAS	6,53	X		X	X		X
80,00	2,00			3,90	X				X	X
80,00	5,00			9,39				X		X
83,00	1,50			3,06	X					
84,00	2,00			4,11	X	X	X			
85,00	2,00			4,16	X		X			
88,90	2,00			4,35	X	X	X			
88,90	2,11	3"	Sch 5 S	4,59		X	X			
88,90	3,00			6,45	X		X			
88,90	3,05	3"	Sch 10 S	6,56		X	X	X	X	X
88,90	3,20			6,87	X		X	X	X	
88,90	4,00	3"	GAS	8,50	X	X	X			
88,90	5,49	3"	Sch 40 S STD	11,47		X	X	X	X	X
88,90	7,62	3"	Sch 80 S XS	15,52				X	X	X
88,90	11,10	3"	Sch 160	21,68				X	X	X
88,90	15,24	3"	XXS	29,52				X		X
101,60	1,50			3,76	X		X■			
101,60	2,00			4,99	X	X	X			
101,60	3,00			7,41	X		X			
101,60	3,05	3.1/2"	Sch 10 S	7,53		X	X	X		X
101,60	3,60			8,83			X			
101,60	5,74	3.1/2"	Sch 40 S STD	13,79		X	X	X	X	X

**Buizen
naadloos/gelast**
 **Tubes
seamless/welded**
**Rohre
nahtlos/geschweisst**
 **Tubes soudés/
sans soudure**

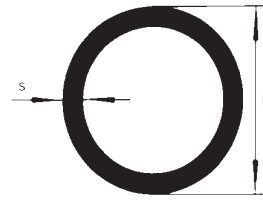

Omschrijving op pagina 6-11
Description on page 6-11
Umschreibung auf Seite 6-11
Description à la page 6-11

- = ook geslepen K 320
- = also ground K 320
- = auch geschliffen K 320
- = aussi polis G 320

Afmeting Size Abmessung Dimension		Afmeting Size Abmessung Dimension		Gewicht Weight Gewicht Poids	304 (1.4301)	304L (1.4306) (1.4307)	316L (1.4404) (1.4571)	304(L) (1.4306) (1.4307) (1.4301)	321(H) (1.4541)	316(L) (1.4404) (1.4571)
D mm	s mm	D inch	s inch / sch	± Kg/m	gelast welded geschw. soudés	gelast welded geschw. soudés	gelast welded geschw. soudés	naadloos seamless nahtlos sans soudure	naadloos seamless nahtlos sans soudure	naadloos seamless nahtlos sans soudure
101,60	8,08	3.1/2"	Sch 80 S XS	18,92				X		X
104,00	2,00			5,11	X	X	X			
106,00	3,00			7,74	X		X			
108,00	2,00			5,31	X		X			
108,00	3,00			7,88	X		X			
108,00	4,00			10,42	X		X	X		X
114,30	2,00			5,62	X	X	X			
114,30	2,11	4"	Sch 5 S	5,93		X				
114,30	3,00			8,36	X					
114,30	3,05	4"	Sch 10 S	8,49		X	X	X	X	X
114,30	3,60			9,98	X	X	X			X
114,30	4,00			11,05	X	X	X			X
114,30	6,02	4"	Sch 40 S STD	16,34		X	X	X	X	X
114,30	8,56	4"	Sch 80 S XS	22,70				X	X	X
114,30	13,49	4"	Sch 160	34,08				X	X	X
114,30	17,12	4"	XXS	41,66						X
129,00	2,00			6,30	X		X			
133,00	3,00			9,77	X		X			
133,00	4,00			12,92	X		X			X
139,70	2,00			6,90	X	X	X			
139,70	3,00			10,27	X	X	X			
139,70	4,00			13,59	X		X	X		X
141,30	3,40	5"	Sch 10 S	11,74		X	X	X	X	X
141,30	6,55	5"	Sch 40 S STD	22,13		X	X	X	X	X
141,30	9,53	5"	Sch 80 S XS	31,44				X	X	X
141,30	15,88	5"	Sch 160	49,87				X		X
154,00	2,00			7,61	X		X			
156,00	3,00			11,49	X		X			
159,00	2,00			7,86	X		X			
159,00	3,00			11,72	X		X			
159,00	4,00			15,52	X		X			
168,28	2,77	6"	Sch 5 S	11,48		X	X			
168,28	3,40	6"	Sch 10 S	14,04		X	X	X	X	X
168,28	7,11	6"	Sch 40 S STD	28,69		X	X	X	X	X
168,28	7,11	6"	Sch 40 S STD	28,72		X	X	X	X	X
168,28	10,97	6"	Sch 80 S XS	43,25				X	X	X
168,28	18,26	6"	Sch 160S	68,59				X		X
168,30	2,00			8,33	X	X	X			
168,30	3,00			12,42	X	X	X			
168,30	4,00			16,46	X		X			
168,30	5,00			20,44	X	X	X			X
204,00	2,00			10,12	X	X	X			
206,00	3,00			15,25	X		X			
208,00	4,00			20,43	X					
219,08	2,77	8"	Sch 5 S	15,00		X	X			

**Buizen
naadloos/gelast**

**Tubes
seamless/welded**

**Rohre
nahtlos/geschweisst**

**Tubes soudés/
sans soudure**

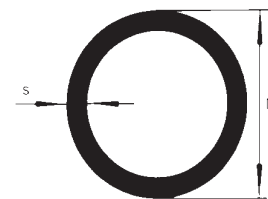

Omschrijving op pagina 6-11
Description on page 6-11
Umschreibung auf Seite 6-11
Description à la page 6-11

- = ook geslepen K 320
- = also ground K 320
- = auch geschliffen K 320
- = aussi polis G 320

Afmeting Size Abmessung Dimension		Afmeting Size Abmessung Dimension		Gewicht Weight Gewicht Poids	304 (1.4301)	304L (1.4306) (1.4307)	316L (1.4404)	304(L) (1.4306) (1.4307)	321(H) (1.4541)	316(L) (1.4404)
D mm	s mm	D inch	s inch / sch	± Kg/m	gelast welded geschw. soudés	gelast welded geschw. soudés	gelast welded geschw. soudés	naadloos seamless nahtlos sans soudure	naadloos seamless nahtlos sans soudure	naadloos seamless nahtlos sans soudure
219,08	3,76	8"	Sch 10 S	20,27		X	X	X		X
219,08	6,35	8"	Sch 20	33,57		X	X	X	X	X
219,08	8,18	8"	Sch 40 S STD	43,20		X	X	X	X	X
219,08	12,70	8"	Sch 80 S XS	65,63		X		X	X	X
219,08	23,01	8"	Sch 160	112,97						X
219,10	2,00			10,87	X	X	X			
219,10	2,60			14,10			X			
219,10	3,00			16,23	X		X			
219,10	4,00			21,54	X		X			
254,00	2,00			12,62	X	X	X			
256,00	3,00			19,01	X		X			
273,00	2,00			13,57	X	X	X			
273,00	3,00			20,28	X	X	X			
273,05	4,19	10"	Sch 10 S	28,21		X	X	X		X
273,05	6,35	10"	Sch 20	42,41		X	X	X		X
273,05	9,27	10"	Sch 40 S STD	61,23		X	X	X	X	X
273,05	12,70	10"	Sch 60 / Sch 80 XS	82,79		X		X		X
304,00	2,00			15,12	X		X			
306,00	3,00			22,76	X		X			
323,85	4,57	12"	Sch 10 S	36,54		X	X	X		X
323,85	6,35	12"	Sch 20	50,49		X	X			
323,85	9,53	12"	Sch 40 S STD	75,00		X	X	X	X	X
323,85	12,70	12"	Sch 80 S XS	98,95		X	X	X		X
323,90	2,00			16,12	X	X	X			
323,90	3,00			24,11	X		X			
355,60	4,78	14"	Sch 10 S	41,99		X	X		X	X
355,60	7,92	14"	Sch 20	68,95			X			X
355,60	9,53	14"	Sch 30 / 40 S	82,83		X	X	X		X
356,00	3,00			26,60	X		X			
406,00	3,00			30,30	X	X	X			
406,40	4,00			40,26	X					
406,40	4,78	16"	Sch 10 S	48,07		X	X			
406,40	7,92	16"	Sch 20	79,03		X	X			
406,40	9,53	16"	Sch 40 S STD	94,70		X	X	X		X
456,00	3,00			34,03	X		X			
457,20	4,78	18"	Sch 10 S	54,15		X	X			
506,00	3,00			37,80	X		X			
508,00	4,00			50,48	X		X			
508,00	5,56	20"	Sch 10 S	69,95		X	X			
508,00	9,53	20"	Sch 20 / Sch 40 STD	118,95		X	X			
606,00	3,00			45,30	X		X			
609,60	6,35	24"	Sch 10 / Sch 10 S	95,49		X	X			
609,60	9,53	24"	Sch 20 / Sch 40	143,20		X	X			
708,00	4,00			70,51			X			

Machinebuizen

Hollow bars

Hohlstahl

Ebauches

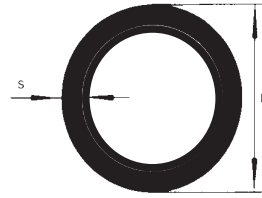

Machinebuizen

Hollow bars

Hohlstahl

Ebauches

Spec. 001

Naadloze roestvaststalen machinebuizen volgens EN 10216-5 met zeer goede machinale bewerkbaarheid.

Toleranties volgens ISO 2938.

Keuringsrapport volgens EN 10204/3.1.

Excentriciteit 12,5% max.

Seamless hollow bars acc. to EN 10216-5 with improved machinability.

Tolerances acc. to ISO 2938.

Inspection certificate as per EN 10204/3.1.

Eccentricity 12,5% max.

Nahtlose Hohlstähle nach EN 10216-5 mit verbesserte maschinelle Bearbeitung.

Toleranzen nach ISO 2938.

Abnahmeprüfzeugnis nach EN 10204/3.1.

Excentrizität 12,5% max.

Ebauches sans soudure, conformes à la norme EN 10216-5, usinabilité accrue.

Tolérance conforme à la norme ISO 2938.

Certificat d'inspection selon la norme EN 10204/3.1.

Excentricité 12,5 % max.

Machinebuizen

Hollow bars

Hohlstahl

Ebauches

Omschrijving op pagina 19
Description on page 19
Umschreibung auf Seite 19
Description à la page 19

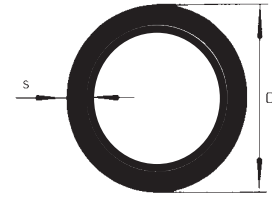

Uitwendige diameter Outside diameter Aussendurchmesser Diamètre extérieur D	Wanddikte Wall thickness Wanddicke Epaisseur de paroi s	Inwendige diameter Inside diameter Innendurchmesser Intérieur	Gewicht Weight Gewicht Poids +/- Kg/m	1.4306 1.4307	1.4404 1.4571
32	6,0	20	4,20	X	X
32	8,0	16	5,07	X	X
36	5,5	25	4,55	X	X
36	8,0	20	5,91	X	X
36	10,0	16	6,78	X	X
40	6,0	28	5,59	X	X
40	7,5	25	6,47	X	X
40	10,0	20	7,83	X	X
45	6,5	32	6,70	X	X
45	8,5	28	8,17	X	X
45	12,5	20	10,50	X	X
50	7,0	36	8,01	X	X
50	9,0	32	9,70	X	X
50	12,5	25	12,10	X	X
56	8,0	40	10,20	X	X
56	10,0	36	12,10	X	X
56	14,0	28	15,20	X	X
63	6,5	50	9,91	X	X
63	11,5	40	15,40	X	X
63	15,5	32	19,00	X	X
71	7,5	56	12,90	X	X
71	13,0	45	19,60	X	X
71	15,5	40	22,30	X	X
71	17,5	36	24,40	X	X
75	7,5	60	13,80	X	X
75	12,5	50	20,70	X	X
75	17,5	40	26,00	X	X
80	8,5	63	16,40	X	X
80	15,0	50	25,30	X	X
80	17,5	45	28,30	X	X
80	20,0	40	30,90	X	X
85	9,0	67	18,50	X	
85	15,0	55	27,80	X	X
85	20,0	45	33,50	X	X
90	9,5	71	20,60	X	X
90	13,5	63	27,10	X	X
90	17,0	56	32,30	X	X
90	20,0	50	36,10	X	X
95	10,0	75	23,10	X	X
95	14,0	67	30,30	X	X
95	22,5	50	42,10	X	X
100	10,0	80	24,40	X	X
100	14,5	71	32,70	X	X
100	22,0	56	42,30	X	X

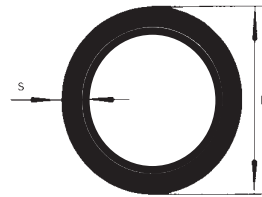

Omschrijving op pagina 19
 Description on page 19
 Umschreibung auf Seite 19
 Description à la page 19

Uitwendige diameter Outside diameter Aussendurchmesser Diamètre extérieur D	Wanddikte Wall thickness Wanddicke Epaisseur de paroi s	Inwendige diameter Inside diameter Innendurchmesser Intérieur	Gewicht Weight Gewicht Poids +/- Kg/m	1.4306 1.4307	1.4404 1.4571
106	13,0	80	32,30	X	X
106	17,5	71	40,60	X	X
106	21,5	63	47,10	X	X
106	25,0	56	52,10	X	X
112	11,0	90	30,20	X	X
112	16,0	80	40,60	X	X
112	24,5	63	55,30	X	X
118	14,0	90	39,00	X	X
118	19,0	80	49,40	X	X
118	27,5	63	64,80	X	X
125	12,5	100	38,30	X	X
125	17,5	90	49,80	X	X
125	22,5	80	60,20	X	X
125	27,0	71	68,50	X	X
132	13,0	106	42,00	X	X
132	21,0	90	61,10	X	X
132	26,0	80	73,15	X	X
132	30,5	71	79,70	X	X
140	14,0	112	47,80	X	X
140	20,0	100	63,30	X	X
140	25,0	90	77,73	X	X
140	30,0	80	85,20	X	X
150	12,5	125	47,40	X	X
150	22,0	106	74,20	X	X
150	27,5	95	92,00	X	
150	35,0	80	103,30	X	X
160	14,0	132	56,20	X	X
160	24,0	112	85,80	X	X
160	35,0	90	114,30	X	X
170	15,0	140	68,30	X	X
170	20,0	130	80,20	X	X
170	26,0	118	98,40	X	X
170	35,0	100	126,71		X
180	15,0	150	68,40	X	X
180	20,0	140	86,10	X	X
180	27,5	125	110,00	X	X
180	40,0	100	146,20	X	X
190	15,0	160	73,00	X	X
190	20,0	150	91,90	X	X
190	29,0	132	123,00	X	X
190	42,0	106	162,40	X	
200	20,0	160	97,60	X	X
200	25,0	150	117,00	X	X

Machinebuizen**Hollow bars****Hohlstahl****Ebauches**

Omschrijving op pagina 19
 Description on page 19
 Umschreibung auf Seite 19
 Description à la page 19

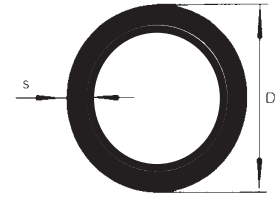

Uitwendige diameter Outside diameter Aussendurchmesser Diamètre extérieur D	Wanddikte Wall thickness Wanddicke Epaisseur de paroi s	Inwendige diameter Inside diameter Innendurchmesser Intérieur	Gewicht Weight Gewicht Poids +/- Kg/m	1.4306 1.4307	1.4404 1.4571
200	30,0	140	134,00	X	X
200	44,0	112	179,30	X	X
212	21,0	170	109,00	X	X
212	41,0	130	182,00	X	X
224	22,0	180	121,00	X	X
224	42,0	140	205,00	X	X
236	23,0	190	133,00	X	X
236	43,0	150	216,00		X
250	25,0	200	152,34	X	X

Profielbuizen

Hollow sections

Vierkant- und Rechteck Rohre

Tubes profilés

Profielbuizen

Hollow sections

Vierkant- und
Rechteck Rohre

Tubes profilés

Spec. 001

Vierkante en rechthoekige roestvaststalen buizen in lengten van ca. 6 m.

Toleranties volgens de opgave van de fabrikant

Square and rectangular hollow sections in lengths of ca 6 m.

Tolerances as per mill's standard.

Quadratische und rechteckige Edelstahlrohre in Längen von ca. 6 m.

Toleranzen nach Angabe der Hersteller.

Tubes profilés carrés et rectangulaires d'une longueur de 6 mètres environ.

Tolérances conformes aux normes convenues.

Buisprofielen
rechthoek

Rectangular
hollow sections

Rechteckrohre

Tubes profilés
rectangulaires

Buisprofielen rechthoek
Rectangular hollow sections
Rechteckrohre
 Tubes profilés rectangulaires

Omschrijving op pagina 23
Description on page 23
Umschreibung auf Seite 23
Description à la page 23

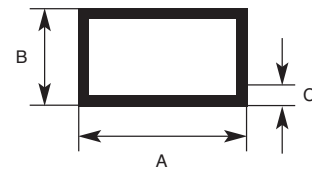

Afmeting Size Abmessung Dimension			Gewicht Weight Gewicht Poids +/- Kg/m	1.4301	1.4301 Geslepen K320 Ground K320 Geschliffen K320 Polis G320	1.4404
A	B	C				
20	10	1,5	0,66	X		
25	15	1,5	0,90	X		
30	15	1,5	1,02	X	X	
30	20	1,5	1,14	X		
30	20	2,0	1,49	X		
40	20	1,5	1,38	X	X	
40	20	2,0	1,81	X	X	X
50	20	2,0	2,13	X	X	
50	25	1,5	1,74	X		
50	25	2,0	2,29	X	X	
50	30	2,0	2,45	X	X	X
50	30	3,0	3,60	X		
60	20	2,0	2,45	X	X	
60	30	2,0	2,77	X		
60	30	3,0	4,08	X		X
60	40	2,0	3,09	X	X	
60	40	3,0	4,56	X		
60	40	4,0	5,96	X		X
80	40	2,0	3,73	X	X	X
80	40	3,0	5,52	X	X	X
80	40	4,0	7,22	X		
80	50	3,0	6,01	X		
80	60	3,0	6,47	X		X
80	60	4,0	8,50	X		
100	40	2,0	4,37	X	X	X
100	40	3,0	6,47	X		X
100	50	2,0	4,68	X		
100	50	3,0	6,95	X	X	X
100	50	4,0	9,12	X	X	
100	50	5,0	11,23	X		
100	60	3,0	7,43	X		
100	60	4,0	9,81	X		
100	60	5,0	12,40	X		
100	80	3,0	8,39	X		
120	40	3,0	7,43	X		
120	60	3,0	8,39	X	X	X
120	60	4,0	11,08	X		X
120	60	5,0	13,73	X		
120	80	3,0	9,34	X		
120	80	4,0	12,36	X		
120	80	5,0	15,32	X		X
150	50	3,0	9,34	X		
150	50	4,0	12,39	X		
150	100	3,0	11,73	X		

Buisprofielen
rechthoek

Rectangular
hollow sections

Rechteckrohre

Tubes profilés
rectangulaires

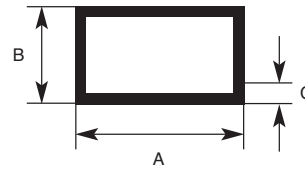

Omschrijving op pagina 23
Description on page 23
Umschreibung auf Seite 23
Description à la page 23

Afmeting Size Abmessung Dimension			Gewicht Weight Gewicht Poids +/- Kg/m	1.4301	1.4301 Geslepen K320 Ground K320 Geschliffen K320 Polis G320	1.4404
A	B	C				
150	100	4,0	15,55	X		
150	100	5,0	19,40	X		
160	80	4,0	14,91	X		
160	80	5,0	18,00	X		
200	100	3,0	14,13	X		
200	100	4,0	18,74	X		X
200	100	5,0	23,30	X		X
200	100	6,0	27,36	X		X
200	150	4,0	15,00	X		
250	100	5,0	26,80	X		X

Buisprofielen
vierkant

Square
hollow sections

Vierkantrohren

Tubes profilés
carrés

Buisprofielen vierkant
Square hollow sections
Vierkantrohren
Tubes profilés carrés

Omschrijving op pagina 23
Description on page 23
Umschreibung auf Seite 23
Description à la page 23

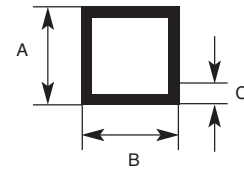

Afmeting Size Abmessung Dimension			Gewicht Weight Gewicht Poids +/- Kg/m	1.4301	1.4301 Geslepen K320 Ground K320 Geschliffen K320 Polis G320	1.4404
A	B	C				
10	10	1	0,29	X		
15	15	1,5	0,66	X		
20	20	1,5	0,90	X	X	X
20	20	2	1,18	X	X	X
25	25	1,5	1,14	X	X	
25	25	2	1,49	X	X	X
30	30	1,5	1,38	X	X	
30	30	2	1,81	X	X	X
30	30	3	2,65	X		X
35	35	2	2,13	X	X	X
40	40	1,2	1,50		X	
40	40	1,5	1,86	X	X	
40	40	2	2,45	X	X	X
40	40	3	3,60	X		X
40	40	4	4,71	X		X
45	45	2	2,77	X		
50	50	2	3,09	X	X	X
50	50	3	4,56	X		X
50	50	4	5,96	X		X
50	50	5	7,32	X		
60	60	2	3,73	X	X	X
60	60	3	5,52	X	X	X
60	60	4	7,22	X		X
60	60	5	8,85	X		X
70	70	3	6,43	X		
70	70	4	8,38	X		
80	80	2	5,00	X	X	X
80	80	3	7,43	X	X	X
80	80	4	9,72	X	X	X
80	80	5	12,10	X		
100	100	2	6,28	X	X	X
100	100	3	9,34	X	X	X
100	100	4	12,36	X		X
100	100	5	15,32	X		X
120	120	3	11,26	X		
120	120	4	14,91	X		
120	120	5	18,51	X		
150	150	3	14,13	X		
150	150	4	18,74	X		
150	150	5	23,30	X		
150	150	6	30,00	X		
200	200	3	18,86	X		
200	200	4	25,11	X		
200	200	5	30,80	X		X

Hoekprofiel (gelijkzijdig)

Angleprofiles (equal)

Winkelstahl (egal)

Cornières (égaux)

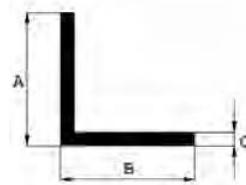

Hoekprofiel

Angleprofiles

Winkelstahl

Cornières

Spec. 001

Warmgewalst hoekprofiel, toleranties volgens DIN 1028.

Lengtes van 6 meter.

Hot finished equal angle, tolerances in accordance with DIN 1028.

Lengths of 6 metres.

Warmgewalzt Winkelstahl, Toleranzen nach DIN 1028.

Längen von 6 Meter.

Cornières égales laminées à chaud, tolérance conforme à la norme DIN 1028.

Longueur de 6 mètres.

Afmeting Size Abmessung Dimension			Gewicht Weight Gewicht Poids	304 (L)	316 (L)				
A	B	C							
20	20	3	0,89	X	X				
25	25	3	1,13	X	X				
30	30	3	1,37	X	X				
35	35	4	2,11	X	X				
40	40	4	2,43	X	X				
40	40	5	3,00	X					
50	50	5	3,80	X	X				
60	60	6	5,47	X	X				
70	70	7	7,47	X	X				
80	80	8	9,73	X	X				
100	100	10	15,20	X	X				

Strip

Flat bars

Flachstahl

Plats

Strip

Flat bars

Flachstahl

Plats

Spec. 001

Geslit platstaal, toleranties volgens DIN 1017.

Lengtes van 4 meter.

Slit flat bars, tolerances in accordance with DIN 1017.

Lengths of 4 metres.

Flachstahl, vom Band geschnitten, Toleranzen nach DIN 1017.

Längen von 4 Meter.

Plats refendus, tolérance conforme à la norme DIN 1017.

Longueur de 4 mètres.

Strip Flat bars Flachstahl Plats

Omschrijving op pagina 28
Description on page 28
Umschreibung auf Seite 28
Description à la page 28

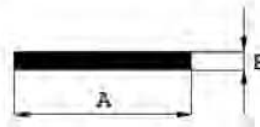

Strip

Flat bars

Flachstahl

Plats

Afmeting Size Abmessung Dimension		Gewicht Weight Gewicht Poids	304 (L)	316 (L)						
A	B									
10	3	0,236	X							
15	3	0,353	X							
15	4	0,471	X							
20	3	0,471	X	X						
20	4	0,628	X	X						
20	5	0,785	X	X						
20	6	0,942	X	X						
20	8	1,26	X	X						
20	10	1,57	X							
25	3	0,589	X	X						
25	4	0,785	X	X						
25	5	0,981	X	X						
25	6	1,18	X	X						
25	8	1,57	X	X						
25	10	1,96	X	X						
30	3	0,707	X	X						
30	4	0,942	X	X						
30	5	1,18	X	X						
30	6	1,41	X	X						
30	8	1,88	X	X						
30	10	2,36	X	X						
30	12	2,83	X							
35	3	0,824	X							
35	4	1,10	X							
35	5	1,37	X	X						
35	8	2,20	X	X						
35	10	2,75	X	X						
40	3	0,942	X	X						
40	4	1,26	X	X						
40	5	1,57	X	X						
40	6	1,88	X	X						
40	8	1,00	X	X						
40	10	3,14	X	X						
40	12	3,77	X							
40	15	4,71	X	X						
50	3	1,178	X	X						
50	4	1,57	X	X						
50	5	1,96	X	X						
50	6	2,36	X	X						
50	8	3,14	X	X						
50	10	3,93	X	X						
50	12	4,71	X							

Strip

Flat bars

Flachstahl

Plats

Strip
Flat bars
Flachstahl
Plats

Omschrijving op pagina 28
Description on page 28
Umschreibung auf Seite 28
Description à la page 28

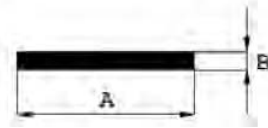

Table with columns: Afmeting Size Abmessung Dimension (A, B), Gewicht Weight Gewicht Poids, 304 (L), 316 (L), and several empty columns. Rows list dimensions and weights for various sizes.

Rondstaf

Round bars

Rundstahl

Barres rondes

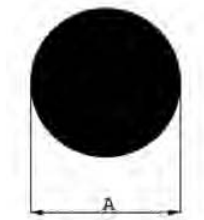

Rondstaf

Round bars

Rundstahl

Barres rondes

Spec. 001

Warmgewalst / geschild stafstaal, toleranties volgens DIN 1013.

Lengtes van 4 - 6 meter.

Round bars, hot rolled / peeled, tolerances in accordance with DIN 1013.

Random lengths of 4 - 6 metres.

Rundstahl, warmgewalzt / geschält, Toleranzen nach DIN 1013.

Längen von 4 - 6 Meter.

Barres rondes laminées à chaud / écrouées, tolérance conforme à la norme DIN 1013.

Longueur de 4 - 6 mètres.

Spec. 002

Koudgetrokken / geslepen stafstaal, toleranties volgens EN 10278.

Lengtes van 3 - 3,2 meter.

Round bars, cold drawn / ground, tolerances in accordance with EN 10278.

Random lengths of 3 - 3,2 metres.

Rundstahl, kaltgezogen / geschliffen, Toleranzen nach EN 10278.

Längen von 3 - 3,2 Meter.

Barres rondes recuit blanc / rectifiées, tolérance conforme à la norme EN 10278.

Longueur de 3 - 3,2 mètres.

Rondstaf**Round bars****Rundstahl****Barres rondes**

Rondstaf
Round bars
Rundstahl
Barres rondes

Omschrijving op pagina 31
 Description on page 31
 Umschreibung auf Seite 31
 Description à la page 31



Afmeting Size Abmessung Dimension A	Warmgewalst / geschild Hot rolled / peeled Warmgewalzt / geschält Chaud / écroustées	Koudgetrokken / Geslepen Cold drawn / grinded Kaltgezogen / geschliffen Recuits blanc / rectifié	Gewicht Weight Gewicht Poids	304 (L)	316 (L)
4		X	0,099	X	X
5		X	0,154	X	X
6		X	0,222	X	X
8		X	0,395	X	X
10		X	0,617	X	X
12		X	0,888	X	X
14		X	1,208	X	
15		X	1,387	X	X
16		X	1,578	X	X
18		X	1,998	X	
20		X	2,466	X	X
22		X	2,984	X	
25		X	3,853	X	X
30		X	5,549	X	
35		X	7,553	X	X
40		X	9,865	X	X
45		X	12,49	X	
50		X	15,41	X	X
60		X	22,20	X	X
60	X		22,20	X	X
70	X		30,21	X	X
80	X		39,46	X	X
90	X		49,94	X	X
100	X		61,65	X	X

Lasbochten

Elbows

Rohrbogen

Coudes

Lasbochten

Elbows

Rohrbogen

Coudes

Spec. 001

Lasbochten R=1,5D. Keuringsrapport volgens EN 10204/3.1.

Elbows R=1,5D. Inspection certificate as per EN 10204/3.1.

Rohrbogen R=1,5D. Abnahmeprüfzeugnis nach EN 10204/3.1.

Coudes R=1,5 D. Certificat d'inspection en vertu de la norme EN 10204/3.1.

Spec. 002

Zuivel -lasbochten 90° volgens DIN 11852. Geslepen of ongeslepen. Keuringsrapport volgens EN 10204/3.1.

Dairy - elbows 90° acc. to DIN 11852 . Polished or not polished. Inspection certificate as per EN 10204/3.1.

Getränkeleitungsbogen, 90° nach DIN 11852 . Geschliffen oder nicht geschliffen. Abnahmeprüfzeugnis nach EN 10204/3.1.

Coudes 90° pour laiterie conformes à la norme ISO 11852. Rectifiée ou non rectifiée. Certificat d'inspection selon la norme EN 10204/3.1.

Spec. 003

Lasbochten volgens ASTM A403 en ASME B16.9. Keuringsrapport volgens EN 10204/3.1 van zowel de bocht als het basismateriaal.
Alle bochten 100% op materiaalverwisseling getest. Bochten tweevoudig gecertificeerd.

Elbows acc. to ASTM A403 and ASME B16.9. Inspection certificate as per EN 10204/3.1 for the elbow and the base material.
All elbows 100 % PMI- tested. Elbows dual certified.

Rohrbogen nach ASTM A403 und ASME B16.9. Abnahmeprüfzeugnis nach EN 10204/3.1 für Bogen und Grundwerkstoff.
Alle Bogen mit 100% Verwechslungsprüfung. Bogen zweifach zertifiziert.

Coudes soudés conformes aux normes ASTM A403 et ASME B16.9. Certificat d'inspection selon la norme EN 10204/3.1, pour le coude et la matière de base. Tous les coudes sont testés PMI à 100 %. Double certification.

Spec. 004

Naadloze lasbochten volgens ASTM A403 en ASME B16.9.

Keuringsrapport volgens EN 10204/3.1 van zowel de bocht als het basismateriaal.

Alle bochten aanvullend getest op interkristallijne corrosie volgens ASTM A262 pr.E en PMI d.m.v. spectrograph.

Hardheid HRC 22 max. volgens NACE MR01-75 laatste uitgave Bochten tweevoudig gecertificeerd.

Seamless elbows acc. to ASTM A403 and ASME B16.9.

Inspection certificate as per EN 10204/3.1 for the elbow and the base material.

All elbows additionally tested on intergranular corrosion acc. to ASTM A262 pr E and PMI-tested by spectrograph.

Hardness HRC 22 max. acc. to NACE MR01-75 latest edition. Elbows dual certified.

Nahtlose Rohrbogen nach ASTM A403 und ASME B16.9.

Abnahmeprüfzeugnis nach EN 10204/3.1 für Bogen und Grundwerkstoff.

Alle Bogen zusätzlich geprüft auf Interkristalline Korrosion nach ASTM A262 pr. E und mit Verwechslungsprüfung durch Spectrograph.

Härte HRC max. 22 nach NACE MR01-75 letzte Ausgabe. Bogen zweifach zertifiziert.

Coudes sans soudure conformes aux normes ASTM A403 et ASME B16.9.

Certificat d'inspection selon la norme EN 10204/3.1, pour le coude et la matière de base.

Coudes testés également pour leur corrosion intergranulaire conformément à la norme ASTM A262 pr. E. Test PMI par spectrographe.

Dureté HCR 22 max., conformément à la norme NACE MR01-75 (dernière édition). Double certification.

Een groot deel van ons assortiment naadloze fittingen is ook leverbaar van door STOOMWEZEN goedgekeurde leveranciers

A major part of our stockprogramme seamless fittings is also available from STOOMWEZEN approved suppliers

Einen grossen Teil aus unserem nahtlosen Fittingsortiment können wir auch nach STOOMWEZEN-anerkannten Lieferanten liefern.

La plupart des raccords sans soudure de notre gamme sont également disponibles et fabriqués par des fournisseurs agréés « STOOMWEZEN ».

Omschrijving op pagina 33-34
 Description on page 33-34
 Umschreibung auf Seite 33-34
 Description à la page 33-34

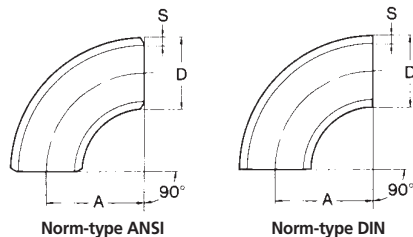

Lasbochten

Elbows

Rohrbogen

Coudes

- = Volgens DIN 11852, gepolijst - nach DIN 11852, poliert
to DIN 11852, polished - selon la norme DIN 11852, polis
- = Volgens DIN 11852, gebeitst - nach DIN 11852, gebeitzt
- to DIN 11852, pickled - selon la norme DIN 11852, décapés
- * = Afmetingen vlg ASME B16.9, vervaardigd vlg ASTM A403, afgeschuind vlg ASME B16.25
- * = Dimensions to ASME B16.9, produced to ASTM A403, ends bevelled to ASME B16.25
- * = Abmessungen nach ASME B16.9, hergestellt nach ASTM A403, abgeschrägt nach ASME B16.25
- * = Dimensions selon la norme ASME B16.9, fabriqués selon la norme ASTM A403, extrémités chanfreinées selon la norme ASME B16.25

Afmeting				Gewicht	Radius		type	304/304L	304/304L	316/316L	316/316L
Size				Weight				1.4306	1.4306	1.4404	1.4404
Abmessung				Gewicht				1.4307	1.4307	gelast	naadloos
Dimension				Poids				gelast	naadloos	welded	seaml.
D	S			+/- Kg	A			geschw.	nahtl.	geschw.	nahtl.
				St./pc.				soudés	sans soudure	soudés	sans soudure
13,50	2,30			0,03	20,0	1,5D	90°				X
15,00	1,50			0,03	27,5	1,5D	90°				X
17,20	1,60			0,03	25 / 27,5	1,5D	90°			X	
17,20	2,30			0,04	25 / 27,5	1,5D	90°				X
18,00	1,50			0,03	23 / 22,5	1,5D	90°				X
20,00	1,50			0,03	25 / 26	1,5D	90°			X	
20,00	2,00			0,04	25 / 26	1,5D	90°			X	
21,30	1,60			0,03	28 / 38	1,5D	90°			X	
21,30	2,00			0,06	28 / 38	5S	90°			X	
21,30	2,60			0,10	28 / 38	5S	90°				X
21,34	2,11	1/2"	Sch 10 S *	0,06	38,1	LR *	90°	X	X	X	X
21,34	2,11	1/2"	Sch 10 S *	0,03	38,1	LR *	45°		X		X
21,34	2,77	1/2"	Sch 40 S STD *	0,08	38,1	LR *	90°	X	X	X	X
21,34	2,77	1/2"	Sch 40 S STD *	0,04	38,1	LR *	45°		X		X
21,34	3,73	1/2"	Sch 80 S XS *	0,10	38,1	LR *	90°		X		X
21,34	3,73	1/2"	Sch 80 S XS *	0,05	38,1	LR *	45°		X		X
21,34	4,78	1/2"	Sch 160 *	0,12	38,1	LR *	90°				X
23,00	1,50			0,04	25 / 30	1,5D	90°			X	
25,00	1,50			0,04	27,5 / 37	1,5D	90°	X		X	
25,00	2,00			0,05	27,5 / 37		90°	X		X	
25,40	1,50			0,04	38,0		90°			X■□	
26,67	2,11	3/4"	Sch 10 S *	0,06	28,5 / 38,1	LR *	90°	X	X	X	X
26,67	2,11	3/4"	Sch 10 S *	0,03	28,5 / 38,1	LR *	45°		X		X
26,67	2,87	3/4"	Sch 40 S STD *	0,10	28,5 / 38,1	LR *	90°	X	X	X	X
26,67	2,87	3/4"	Sch 40 S STD *	0,05	28,5 / 38,1	LR *	45°	X	X		X
26,67	3,91	3/4"	Sch 80 S XS *	0,12	28,5 / 38,1	LR *	90°		X		X
26,67	3,91	3/4"	Sch 80 S XS	0,06	28,5 / 38,1	LR *	45°				X
26,67	5,56	3/4"	Sch 160 *	0,15	28,5 / 38,1	LR *	90°		X		X
26,67	5,56	3/4"	Sch 160 *	0,08	28,5 / 38,1	LR *	45°				X
26,90	1,60			0,05	28,6	1,5D	90°	X		X	
26,90	2,00			0,10	29,00	5S	90°			X	
26,90	2,60			0,14	29,00	5S	90°				X
28,00	1,50			0,08	32,5 / 37		90°			X■□	
28,00	1,50			0,07	32,5	1,5D	90°	X		X	
28,00	2,00			0,07	32,5	3S	90°			X	
30,00	2,00			0,07	33,5 / 38	1,5D	90°	X		X	
32,00	1,50			0,06	35,0		90°			X■□	
32,00	2,00			0,08	35,0	1,5D	90°	X			
33,40	2,77	1"	Sch 10 S *	0,15	38,1	LR *	90°	X	X	X	X
33,40	2,77	1"	Sch 10 S *	0,08	38,1	LR *	45°		X		X

Omschrijving op pagina 33-34
 Description on page 33-34
 Umschreibung auf Seite 33-34
 Description à la page 33-34

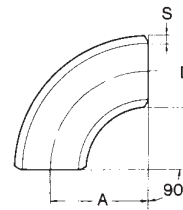

Norm-type ANSI

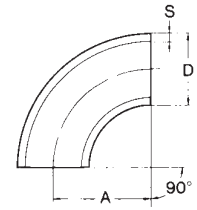

Norm-type DIN

- = Volgens DIN 11852, gepolijst - nach DIN 11852, poliert
 to DIN 11852, polished - selon la norme DIN 11852, polis
- = Volgens DIN 11852, gebeitst - nach DIN 11852, gebeitzt
 - to DIN 11852, pickled - selon la norme DIN 11852, décapés
- * = Afmetingen vlg ASME B16.9, vervaardigd vlg ASTM A403, afgeschuind vlg ASME B16.25
- * = Dimensions to ASME B16.9, produced to ASTM A403, ends bevelled to ASME B16.25
- * = Abmessungen nach ASME B16.9, hergestellt nach ASTM A403, abgeschrägt nach ASME B16.25
- * = Dimensions selon la norme ASME B16.9, fabriqués selon la norme ASTM A403, extrémités chanfreinées selon la norme ASME B16.25

Afmeting Size Abmessung Dimension				Gewicht Weight Gewicht Poids	Radius	type	304/304L	304/304L	316/316L	316/316L
D	S			+/- Kg St./pc.	A		1.4306 1.4307 gelast welded geschw. soudés	1.4306 1.4307 naadloos seaml. nahtl. sans soudure	1.4404 gelast welded geschw. soudés	1.4404 naadloos seaml. nahtl. sans soudure
33,40	2,77	1"	Sch 10 S *	0,08	25,0	SR *	90°			X
33,40	3,38	1"	Sch 40 S STD *	0,16	38,1	LR *	90°	X	X	X
33,40	3,38	1"	Sch 40 S STD *	0,08	38,1	LR *	45°		X	X
33,40	3,38	1"	Sch 40 S STD *	0,10	25,0	SR *	90°		X	X
33,40	4,55	1"	Sch 80 S XS *	0,19	38,1	LR *	90°		X	X
33,40	4,55	1"	Sch 80 S XS *	0,10	38,1	LR *	45°			X
33,40	6,35	1"	Sch 160 *	0,27	38,1	LR *	90°		X	X
33,70	1,60			0,08	38,1	1,5D	90°	X		X
33,70	2,00			0,10	38,1	1,5D	90°	X		X
33,70	2,00			0,18	72,5	5S	90°			X
35,00	1,50			0,10	45 / 50	1,5D	90°			X
38,00	1,50			0,11	45 / 52	1,5D	90°	X		X
38,00	2,00			0,13	45 / 52	1,5D	90°	X		X
38,10	1,50			0,11	56,0		90°			X
40,00	1,50			0,12	54 / 60		90°		X■□	
40,00	1,50			0,12	45,0	1,5D	90°	X		
40,00	2,00			0,16	45 / 60	1,5D	90°	X		X
42,16	2,77	1.1/4"	Sch 10 S *	0,20	47,6	LR *	90°	X	X	X
42,16	3,56	1.1/4"	Sch 40 S STD *	0,25	47,6	LR *	90°	X	X	X
42,16	3,56	1.1/4"	Sch 40 S STD *	0,13	47,6	LR *	45°		X	X
42,16	4,85	1.1/4"	Sch 80 XS *	0,33	47,6	LR *	90°		X	X
42,40	1,60			0,14	47,6	1,5D	90°			X
42,40	2,00			0,16	47,6	1,5D	90°	X		X
42,40	2,00			0,29	92,5		90°			X
44,50	2,00			0,17	51,0	1,5D	90°	X		X
48,26	2,77	1.1/2"	Sch 10 S *	0,28	57,2	LR *	90°	X	X	X
48,26	2,77	1.1/2"	Sch 10 S *	0,14	57,2	LR *	45°	X	X	X
48,26	2,77	1.1/2"	Sch 10 S *	0,19	38,0	SR *	90°		X	X
48,26	3,68	1.1/2"	Sch 40 S STD *	0,36	57,2	LR *	90°	X	X	X
48,26	3,68	1.1/2"	Sch 40 S STD *	0,18	57,2	LR *	45°		X	X
48,26	3,68	1.1/2"	Sch 40 S STD *	0,25	38,0	SR *	90°		X	X
48,26	5,08	1.1/2"	Sch 80 S XS *	0,49	57,2	LR *	90°		X	X
48,26	7,14	1.1/2"	Sch 160 *	0,68	57,2	LR *	90°		X	X
48,26	10,15	1.1/2"	Sch XXS *	0,90	57,2	LR *	90°			X
48,30	1,60			0,19	57,2	1,5D	90°	X		X
48,30	2,00			0,22	57,2	1,5D	90°	X		X
48,30	2,00			0,40	110,0	5S	90°			X
50,80	1,50			0,25	72,0		90°	X	X■□	
51,00	1,50			0,25	67,5	1,5D	90°	X		X
51,00	2,00			0,31	67,5	1,5D	90°	X		X

Omschrijving op pagina 33-34
 Description on page 33-34
 Umschreibung auf Seite 33-34
 Description à la page 33-34

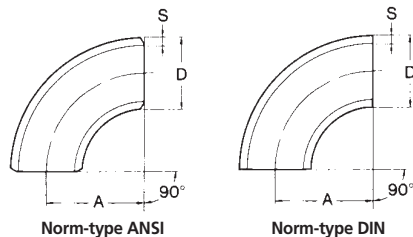

Lasbochten

Elbows

Rohrbogen

Coudes

- = Volgens DIN 11852, gepolijst - nach DIN 11852, poliert
to DIN 11852, polished - selon la norme DIN 11852, polis
- = Volgens DIN 11852, gebeitst - nach DIN 11852, gebeitzt
- to DIN 11852, pickled - selon la norme DIN 11852, décapés
- * = Afmetingen vlg ASME B16.9, vervaardigd vlg ASTM A403, afgeschuind vlg ASME B16.25
- * = Dimensions to ASME B16.9, produced to ASTM A403, ends bevelled to ASME B16.25
- * = Abmessungen nach ASME B16.9, hergestellt nach ASTM A403, abgeschrägt nach ASME B16.25
- * = Dimensions selon la norme ASME B16.9, fabriqués selon la norme ASTM A403, extrémités chanfreinées selon la norme ASME B16.25

Afmeting Size Abmessung Dimension		Gewicht Weight Gewicht Poids		Radius		type		304/304L	304/304L	316/316L	316/316L
D	S	+/- Kg St./pc.	A					1.4306 1.4307 gelast welded geschw. soudés	1.4306 1.4307 naadloos seaml. nahtl. sans soudure	1.4404 gelast welded geschw. soudés	1.4404 naadloos seaml. nahtl. sans soudure
52,00	1,50		0,25	72,0		90°				X■	
53,00	1,50		0,26	72,5 / 75	1,5D	90°	X				
54,00	2,00		0,34	70 / 75	1,5D	90°	X			X	
57,00	2,00		0,34	75,0	1,5D	90°	X			X	
57,00	3,00		0,48	75,0	3S	90°				X	
60,30	1,60		0,29	76,2	1,5D	90°	X			X	
60,30	2,00		0,34	76,2	1,5D	90°	X			X	
60,30	2,00		0,60	135,0	5S	90°				X	
60,33	2,77	2"	0,47	76,2	LR *	90°	X	X	X	X	X
60,33	2,77	2"	0,24	76,2	LR *	45°	X	X	X	X	X
60,33	2,77	2"	0,32	51,0	SR *	90°		X	X	X	X
60,33	3,91	2"	0,65	76,2	LR *	90°	X	X	X	X	X
60,33	3,91	2"	0,33	76,2	LR *	45°	X	X			X
60,33	3,91	2"	0,45	51,0	SR *	90°		X	X	X	X
60,33	5,54	2"	0,89	76,2	LR *	90°		X			X
60,33	5,54	2"	0,45	76,2	LR *	45°		X			X
60,33	8,74	2"	1,40	76,2	LR *	90°		X			X
60,33	8,74	2"	0,70	76,2	LR *	45°		X			X
63,50	1,50		0,33	84,0		90°				X■□	
63,50	1,60		0,33	82,5 / 90	1,5D	90°	X			X	
63,50	2,00		0,37	82,5	1,5D	90°				X	
70,00	2,00		0,50	92,0	1,5D	90°	X			X	
73,03	3,05	2.1/2"	0,79	95,3	LR *	90°	X	X	X	X	X
73,03	3,05	2.1/2"	0,40	95,3	LR *	45°	X			X	X
73,03	5,16	2.1/2"	1,29	95,3	LR *	90°	X	X	X	X	X
73,03	5,16	2.1/2"	0,65	95,3	LR *	45°	X	X	X	X	X
73,03	5,16	2.1/2"	0,87	63,0	SR *	90°		X	X	X	
73,03	7,01	2.1/2"	1,70	95,3	LR *	90°		X			X
76,10	1,50		0,47	95,3		90°				X■□	
76,10	1,60		0,50	95,3	1,5D	90°	X			X	
76,10	2,00		0,62	95,3	1,5D	90°	X			X	
76,10	2,00		1,00	175,0	5S	90°				X	
76,10	3,00		0,90	95,3	1,5D	90°	X			X	
76,10	3,60		1,08	95,3	1,5D	90°				X	
84,00	2,00		0,75	120,0	1,5D	90°	X			X	
88,90	2,00		0,81	114,3	1,5D	90°	X			X	
88,90	2,00		1,39	205,0	5S	90°				X	
88,90	2,60		1,80	114,0	5S	90°				X	
88,90	3,05	3"	1,16	114,3	LR *	90°	X	X	X	X	X
88,90	3,05	3"	0,63	114,3	LR *	45°	X	X	X	X	X

Omschrijving op pagina 33-34
Description on page 33-34
Umschreibung auf Seite 33-34
Description à la page 33-34

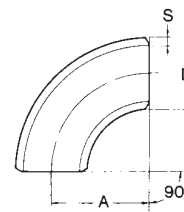

Norm-type ANSI

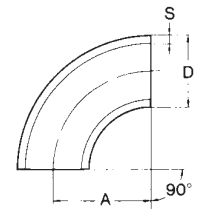

Norm-type DIN

- = Volgens DIN 11852, gepolijst - nach DIN 11852, poliert
to DIN 11852, polished - selon la norme DIN 11852, polis
- = Volgens DIN 11852, gebeitst - nach DIN 11852, gebeizt
- to DIN 11852, pickled - selon la norme DIN 11852, décapés
- * = Afmetingen vlg ASME B16.9, vervaardigd vlg ASTM A403, afgeschuind vlg ASME B16.25
- * = Dimensions to ASME B16.9, produced to ASTM A403, ends bevelled to ASME B16.25
- * = Abmessungen nach ASME B16.9, hergestellt nach ASTM A403, abgeschrägt nach ASME B16.25
- * = Dimensions selon la norme ASME B16.9, fabriqués selon la norme ASTM A403, extrémités chanfreinées selon la norme ASME B16.25

Afmeting Size Abmessung Dimension				Gewicht Weight Gewicht Poids	Radius	type		304/304L	304/304L	316/316L	316/316L
D	S			+/- Kg St./pc.	A			1.4306 1.4307 gelast welded geschw. soudés	1.4306 1.4307 naadloos seaml. nahtl. sans soudure	1.4404 gelast welded geschw. soudés	1.4404 naadloos seaml. nahtl. sans soudure
88,90	3,05	3"	Sch 10 S *	0,77	76,0	SR *	90°		X	X	X
88,90	4,00			1,65	114,5	1,5D	90°			X	
88,90	5,49	3"	Sch 40 S STD *	2,02	114,3	LR *	90°	X	X	X	X
88,90	5,49	3"	Sch 40 S STD *	1,01	114,3	LR *	45°		X		X
88,90	5,49	3"	Sch 40 S STD *	1,38	76,0	SR *	90°		X	X	X
88,90	7,62	3"	Sch 80 S XS *	2,74	114,3	LR *	90°		X		X
88,90	7,62	3"	Sch 80 S XS *	1,37	114,3	LR *	45°				X
88,90	11,13	3"	Sch 160 *	4,02	114,3	LR *	90°				X
101,60	2,00			1,05	133,0	1,5D	90°	X		X■□	
101,60	3,05	3.1/2"	Sch 10 S *	1,56	133,4	LR *	90°	X	X	X	
101,60	5,74	3.1/2"	Sch 40 S STD *	2,84	133,4	LR *	90°	X		X	X
104,00	2,00			1,20	150,0	1,5D	90°	X		X	
104,00	2,00			2,50	250,0	5S	90°			X	
106,00	3,00			2,40	200,0	D+100	90°			X	
108,00	2,00			1,10	142,5	3S	90°			X	
108,00	4,00			2,20	142,5	3S	90°	X		X	
114,30	2,00			1,20	152,4	1,5D	90°	X		X	
114,30	3,05	4"	Sch 10 S *	2,00	152,4	LR *	90°	X	X	X	X
114,30	3,05	4"	Sch 10 S *	1,00	152,4	LR *	45°	X	X	X	X
114,30	3,05	4"	Sch 10 S *	1,33	102,0	SR *	90°	X	X	X	X
114,30	4,00			4,00	152,4	3S	90°			X	
114,30	6,02	4"	Sch 40 S STD *	3,84	152,4	LR *	90°	X	X	X	X
114,30	6,02	4"	Sch 40 S STD *	1,92	152,4	LR *	45°	X	X	X	X
114,30	6,02	4"	Sch 40 S STD *	2,62	102,0	SR *	90°		X	X	X
114,30	8,56	4"	Sch 80 S XS *	5,34	152,4	LR *	90°		X		X
129,00	2,00			2,00	187,5	1,5D	90°	X		X	
133,00	4,00			3,64	181,0	3S	90°	X		X	
139,70	2,00			2,07	190,5	1,5D	90°	X		X	
139,70	2,60			4,30	190,0	5S	90°			X	
139,70	3,00			3,08	190,5	1,5D	90°	X		X	
139,70	4,00			4,10	190,5	1,5D	90°	X		X	
141,30	3,40	5"	Sch 10 S *	3,46	190,5	LR *	90°	X	X	X	X
141,30	6,55	5"	Sch 40 S STD *	6,51	190,5	LR *	90°	X	X	X	X
154,00	2,00			2,60	225,0	1,5D	90°	X		X	
154,00	2,00			4,40	375,0	5S	90°			X	
154,00	2,00			3,00	250,0	D+100	90°	X		X	
156,00	3,00			4,50	250,0	D+100	90°			X	
159,00	3,00			3,95	216,0	3S	90°	X			
159,00	4,00			5,23	216,0	3S	90°			X	
168,28	3,40	6"	Sch 10 S *	4,96	228,5	LR *	90°	X	X	X	X

Omschrijving op pagina 33-34
Description on page 33-34
Umschreibung auf Seite 33-34
Description à la page 33-34

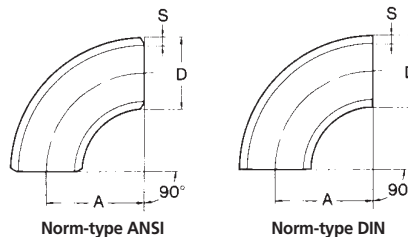

Lasbochten

Elbows

Rohrbogen

Coudes

- = Volgens DIN 11852, gepolijst - nach DIN 11852, poliert
to DIN 11852, polished - selon la norme DIN 11852, polis
- = Volgens DIN 11852, gebeitst - nach DIN 11852, gebeitzt
- to DIN 11852, pickled - selon la norme DIN 11852, décapés
- * = Afmetingen vlg ASME B16.9, vervaardigd vlg ASTM A403, afgeschuind vlg ASME B16.25
- * = Dimensions to ASME B16.9, produced to ASTM A403, ends bevelled to ASME B16.25
- * = Abmessungen nach ASME B16.9, hergestellt nach ASTM A403, abgeschrägt nach ASME B16.25
- * = Dimensions selon la norme ASME B16.9, fabriqués selon la norme ASTM A403, extrémités chanfreinées selon la norme ASME B16.25

Afmeting				Gewicht	Radius	type	304/304L	304/304L	316/316L	316/316L		
Size											Weight	
Abmessung				Gewicht								
Dimension				Poids								
D	S			+/- Kg	A							
				St./pc.								
							1.4306	1.4306	1.4404	1.4404		
							gelast	naadloos	gelast	naadloos		
							welded	seaml.	welded	seaml.		
							geschw.	nahtl.	geschw.	nahtl.		
							soudés	sans soudure	soudés	sans soudure		
168,28	3,40	6"	Sch 10 S *	2,48	228,5	LR *		45°	X	X	X	X
168,28	3,40	6"	Sch 10 S *	3,29	152,0	SR *	90°		X	X	X	X
168,28	7,11	6"	Sch 40 S STD *	10,10	228,6	LR *	90°		X	X	X	X
168,28	7,11	6"	Sch 40 S STD *	5,05	228,6	LR *		45°	X	X	X	X
168,28	7,11	6"	Sch 40 S STD *	6,89	152,0	SR *	90°		X	X	X	X
168,28	10,97	6"	Sch 80 S XS *	15,30	228,6	LR *	90°			X		X
168,28	10,97	6"	Sch 80 S XS *	7,65	228,6	LR *		45°		X		X
168,30	2,00			3,00	228,5	1,5D	90°		X		X	
168,30	2,60			6,05	229,0	5S	90°				X	
168,30	3,00			4,56	228,5	1,5D	90°		X		X	
168,30	4,00			5,90	228,6	1,5D	90°		X			
204,00	2,00			4,80	300,0	D+100	90°		X		X	
204,00	2,00			7,95	500,0	5S	90°				X	
206,00	3,00			7,30	300,0	D+100	90°		X		X	
219,08	3,76	8"	Sch 10 S *	9,55	304,8	LR *	90°		X	X	X	X
219,08	3,76	8"	Sch 10 S *	4,78	304,8	LR *		45°	X	X	X	X
219,08	3,76	8"	Sch 10 S *	6,34	203,0	SR *	90°		X		X	
219,08	8,18	8"	Sch 40 S STD *	20,30	304,8	LR *	90°		X	X	X	X
219,08	8,18	8"	Sch 40 S STD *	10,15	304,8	LR *		45°	X	X	X	X
219,08	8,18	8"	Sch 40 S STD *	13,80	203,0	SR *	90°		X	X	X	X
219,08	12,70	8"	Sch 80 S XS *	30,90	304,8	LR *	90°		X	X		X
219,10	2,00			5,23	305,0	1,5D	90°		X		X	
219,10	3,00			7,80	305,0	1,5D	90°		X		X	
219,10	3,00			13,30	510,0	5S	90°				X	
219,10	4,00			10,00	305,0	1,5D	90°				X	
254,00	2,00			7,00	350,0	D+100	90°		X		X	
256,00	3,00			10,50	350,0	D+100	90°		X		X	
273,00	2,00			8,10	381,0	1,5D	90°		X			
273,00	3,00			12,34	381,0	1,5D	90°		X		X	
273,05	4,19	10"	Sch 10 S *	16,60	381,0	LR *	90°		X	X	X	X
273,05	4,19	10"	Sch 10 S *	8,30	381,0	LR *		45°	X		X	X
273,05	4,19	10"	Sch 10 S *	11,07	254,0	SR *	90°		X		X	
273,05	9,27	10"	Sch 40 S STD *	36,00	381,0	LR *	90°		X	X	X	X
273,05	9,27	10"	Sch 40 S STD *	18,00	381,0	LR *		45°	X	X	X	X
273,05	9,27	10"	Sch 40 S STD *	24,50	254,0	SR *	90°		X		X	
304,00	2,00			10,00	400,0	D+100	90°		X		X	
306,00	3,00			16,20	457,0	1,5D	90°		X		X	
306,00	3,00			14,40	400,0	D+100	90°		X		X	
323,85	4,57	12"	Sch 10 S *	25,80	457,2	LR *	90°		X		X	
323,85	4,57	12"	Sch 10 S *	12,90	457,2	LR *		45°	X		X	

Lasbochten

Elbows

Rohrbogen

Coudes

Omschrijving op pagina 33-34
 Description on page 33-34
 Umschreibung auf Seite 33-34
 Description à la page 33-34

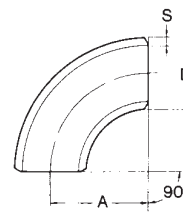

Norm-type ANSI

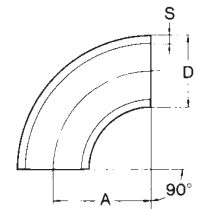

Norm-type DIN

- = Volgens DIN 11852, gepolijst - nach DIN 11852, poliert
 to DIN 11852, polished - selon la norme DIN 11852, polis
- = Volgens DIN 11852, gebeitst - nach DIN 11852, gebeitzt
 - to DIN 11852, pickled - selon la norme DIN 11852, décapés
- * = Afmetingen vlg ASME B16.9, vervaardigd vlg ASTM A403, afgeschuind vlg ASME B16.25
- * = Dimensions to ASME B16.9, produced to ASTM A403, ends bevelled to ASME B16.25
- * = Abmessungen nach ASME B16.9, hergestellt nach ASTM A403, abgeschrägt nach ASME B16.25
- * = Dimensions selon la norme ASME B16.9, fabriqués selon la norme ASTM A403, extrémités chanfreinées selon la norme ASME B16.25

Afmeting Size Abmessung Dimension				Gewicht Weight Gewicht Poids	Radius	type		304/304L	304/304L	316/316L	316/316L
D	S			+/- Kg St./pc.	A			1.4306 gelast welded geschw. soudés	1.4306 naadloos seaml. nahtl. sans soudure	1.4404 gelast welded geschw. soudés	1.4404 naadloos seaml. nahtl. sans soudure
323,85	4,57	12"	Sch 10 S *	17,31	305,0	SR *	90°	X		X	
323,85	9,53	12"	Sch 40 S STD *	53,00	457,2	LR *	90°	X	X	X	X
323,85	9,53	12"	Sch 40 S STD *	26,50	457,2	LR *	45°	X	X	X	
323,90	2,00			16,50	457,0	1,5D	90°	X			
323,90	3,00			17,37	457,0	1,5D	90°	X		X	
355,60	4,78	14"	Sch 10 S *	34,60	533,4	LR *	90°	X		X	
355,60	4,78	14"	Sch 10 S *	11,61	356,0	SR *	45°	X			
356,00	3,00			21,90	533,4	1,5D	90°	X		X	
356,00	3,00			18,80	450,0	D+100	90°	X		X	
406,00	3,00			24,00	500,0	D+100	90°	X		X	
406,40	3,00			28,80	609,6	1,5D	90°	X			
406,40	4,78	16"	Sch 10 S *	45,20	609,6	LR *	90°	X		X	
406,40	4,78	16"	Sch 10 S *	22,60	609,6	LR *	45°	X		X	
406,40	9,53	16"	Sch 40 S STD *	89,20	609,6	LR *	90°	X		X	
456,00	3,00			30,00	550,0	D+100	90°	X		X	
457,20	4,78	18"	Sch 10 S *	57,30	685,8	LR *	90°	X		X	
457,20	4,78	18"	Sch 10 S *	28,65	685,8	LR *	45°	X		X	
506,00	3,00			37,00	600,0	D+100	90°	X			
508,00	5,56	20"	Sch 10 S *	82,00	762,0	LR *	90°	X		X	
606,00	3,00			49,00	700,0	D+100	90°	X			
609,60	6,35	24"	Sch 10 / Sch 10 S *	136,00	914,0	LR *	90°	X		X	
609,60	6,35	24"	Sch 10 / Sch 10 S *	68,00	914,0	LR *	45°	X		X	

Verloopstukken

Reducers

Reduzierungen

Réductions

Verloopstukken

Reducers

Reduzierungen

Réductions

Spec. 001

Gelaste excentrische en concentrische zuivel verloopstukken volgens DIN 11852.

Oppervlak uitwendig en inwendig gebeitst. Keuringsrapport volgens EN 10204/3.1.

Welded eccentric and concentric dairyreducers acc. to DIN 11852.

Surface outside and inside descaled . Inspection certificate as per EN 10204/3.1.

Geschweisste exzentrische und konzentrische Reduzierstücke für Molkereibetriebe nach DIN 11852 .

Aussere und innere Oberfläche gebeitzt . Abnahmeprüfzeugnis nach EN 10204/3.1.

Réductions soudées excentriques et concentriques pour laiterie, conformes à la norme DIN 11852.

Surface intérieure et extérieure décapée. Certificat d'inspection selon la norme EN 10204/3.1.

Spec. 002

Gelaste conc. verloopstukken L=3(D-d) trechertype. Interkristallijne corrosietest volgens EN / ISO 3651-2 of NF A 05-159.

Keuringsrapport volgens EN 10204/3.1.

Welded conc. reducers L=3(D-d) Buckettype. Intergranular corrosion test acc. to EN / ISO 3651-2 or NF A 05-159.

Inspection certificate as per EN 10204/3.1.

Geschweisste konz. Reduzierstücke L=3(D-d). Interkristalline Korrosion Prüfung nach EN / ISO 3651-2 oder NF A 05-159.

Abnahmeprüfzeugnis nach EN 10204/3.1.

Réductions concentriques L=3 (D-d) coniques. Test de résistance à la corrosion intergranulaire conformément à la norme EN / ISO 3651-2 ou NF A 05-159. Certificat d'inspection selon la norme EN 10204/3.1.

Spec. 003

Gelaste excentr. verloopstukken L=3(D-d) trechertype. Interkristallijne corrosietest volgens EN / ISO 3651-2 of NF A 05-159.

Keuringsrapport volgens EN 10204/3.1.

Welded ecc. reducers L=3(D-d) Buckettype. Intergranular corrosion test acc. to EN / ISO 3651-2 or NF A 05-159.

Inspection certificate as per EN 10204/3.1.

Geschweisste exz. Reduzierstücke L=3(D-d). Interkristalline Korrosion Prüfung nach EN / ISO 3651-2 oder NF A 05-159.

Abnahmeprüfzeugnis nach EN 10204/3.1.

Réductions excentriques soudées L=3 (D-d). Test de résistance à la corrosion intergranulaire conformément à la norme EN / ISO 3651-2 ou NF A 05-159. Certificat d'inspection selon la norme EN 10204/3.1.

Spec. 004

Excentrische en concentrische zuivelverloopstukken volgens DIN 11852.

Oppervlak uitwendig gepolijst en inwendig glas-gestraald.

Keuringsrapport volgens EN 10204/3.1.

Eccentric and concentric dairy reducers acc. to DIN 11852.

Surface outside satin polished and inside glass blasted.

Inspection certificate as per EN 10204/3.1.

Exzentrische und konzentrische Reduzierstücke nach DIN 11852.

Oberfläche aussen poliert und innen glas-gestrahlt.

Abnahmeprüfzeugnis nach EN 10204/3.1.

Réductions excentriques et concentriques pour laiterie, conformes à la norme DIN 11852.

Surface extérieure polie et intérieure par soufflage de verre.

Certificat d'inspection selon la norme EN 10204/3.1.

Spec. 005

Gelaste exc. en conc. verloopstukken volgens ASTM A403 en ASME B16.9.

Keuringsrapport volgens EN 10204/3.1 van zowel het verloopstuk als het basismateriaal.

Alle verloopstukken 100% op materiaalverwisseling getest.

Verloopstukken tweevoudig gecertificeerd.

Welded ecc. and conc. reducers acc. to ASTM A403 and ASME B16.9.

Inspection certificate as per EN 10204/3.1 for the reducer and the base material.

All reducers 100 % PMI- tested.

Reducers dual certified.

Geschweisste exz. und konz. Reduzierstücke nach ASTM A403 und ASME B16.9.

Abnahmeprüfzeugnis nach EN 10204/3.1 für Reduzierstück und Grundwerkstoff.

Alle Reduzierstücke mit 100% Verwechslungsprüfung.

Reduzierstücke zweifach zertifiziert.

Réductions concentriques et excentriques conformes aux normes ASTM A403 et ASME B16.9.

Certificat d'inspection selon la norme EN 10204/3.1, pour le reduction et la matière de base.

Toutes les réductions ont été soumises au test PMI à 100 %.

Double certification.

Spec. 006

Naadloze exc. en conc. verloopstukken volgens ASTM A403 en ASME B16.9.

Keuringsrapport volgens EN 10204/3.1 van zowel het verloopstuk als het basismateriaal.

Alle verloopstukken aanvullend getest op interkristallijne corrosie volgens ASTM A262 pr.E en PMI d.m.v.spectrograph.

Hardheid HRC 22 max. volgens NACE MR01-75 laatste uitgave.

Verloopstukken tweevoudig gecertificeerd.

Seamless ecc. and conc. reducers acc. to ASTM A403 and ASME B16.9.

Inspection certificate as per EN 10204/3.1 for the reducer and the base material.

All reducers additionally tested on intergranular corrosion acc. to ASTM A262 pr.E and PMI-tested by spectrograph.

Hardness HRC 22 max. acc. to NACE MR01-75 latest edition.

Reducers dual certified.

Nahtlose exz. und konz. Reduzierstücke nach ASTM A403 und ASME B16.9.

Abnahmeprüfzeugnis nach EN 10204/3.1 für Reduzierstück und Grundwerkstoff.

Alle Reduzierstücke zusätzlich geprüft auf interkristalline Korrosion nach ASTM A262 pr.E und mit Verwechslungsprüfung durch Spectrograph.

Härte HRC max. 22 nach NACE MR01-75 letzte Ausgabe.

Reduzierstücke zweifach zertifiziert.

Réductions concentriques et excentriques sans soudure conformes aux normes ASTM A403 et ASME B16.9.

Certificat d'inspection selon la norme EN 10204/3.1, pour le raccord réducteur et la matière de base.

Toutes les réductions sont également testées pour leur corrosion intergranulaire, conformément à la norme ASTM A262 pr. E et ont été soumis au test PMI par spectrographe.

Dureté HRC 22 max., conformément à la norme NACE MR01-75 (dernière édition).

Double certification.

Een groot deel van ons assortiment naadloze fittingen is ook leverbaar van door STOOMWEZEN goedgekeurde leveranciers.

A major part of our stockprogramme seamless fittings is also available from STOOMWEZEN approved suppliers.

Einen grossen Teil aus unserem nahtlosen Fittingsortiment können wir auch nach STOOMWEZEN-anerkannten Lieferanten liefern.

La plupart des raccords sans soudure de notre gamme sont également disponibles et fabriqués par des fournisseurs agréés « STOOMWEZEN ».

Concentrische lasverloopstukken

Concentric reducers

Konzentrische Reduzierungen

Réductions concentriques

Concentrische lasverloopstukken

gelast en naadloos

Concentric reducers

welded and seamless

Konzentrische Reduzierungen

geschweisst und nahtlos

Réductions concentriques

soudés et sans soudure

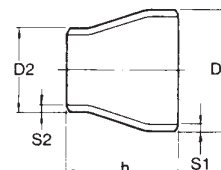

Norm-type A / ANSI

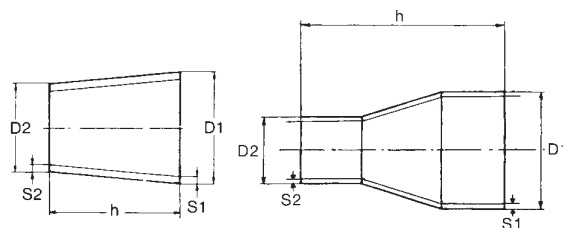

Norm-type B / DIN

Norm-type D / DIN

- = Gepolijst - Polished - Poliirt - Polis
- = Gebeitst - Pickled - Gebeitst - Décapés
- * = Afmeting vgl. ASME B 16.9, vervaardigd vlg. ASTM A403, afgeschuind vgl. ASME B 16.25
- * = Dimension to ASME B.16.9, produced ASTM A403, ends bevelled to ASME B16.25
- * = Abmessung nach ASME B 16.9, hergestellt nach ASTM A403, abgeSchrägt nach ASME B 16.25
- * = Dimension selon la norme ASME B.16.9, fabriqués selon la norme ASTM A403, extrémités chanfreinées selon la norme ASME B16.25

Omschrijving op pagina 41-43
Description on page 41-43
Umschreibung auf Seite 41-43
Description à la page 41-43

mm Afmeting		inch Afmeting								304L	304L	316L	316L
mm Size		inch Size								gelast	naadloos	gelast	naadloos
mm Abmessung		inch Abmessung								welded	seamless	welded	seamless
Dimension en mm		Dimension en pouces								geschw.	nahtlos.	geschw.	nahtlos.
D1	D2	D1	D2		S1	S2	h	Norm type	+/- Kg St./pc.	soudés	sans soudure	soudés	sans soudure
21,30	17,20				2,00	2,00	12,3	B	0,02			X	
21,34	17,15	1/2"	3/8"	Sch 10 S*	2,11	1,65	50,8	A	0,03		X		X
26,67	21,34	3/4"	1/2"	Sch 10 S*	2,11	2,11	38,1	A	0,04	X	X	X	X
26,67	21,34	3/4"	1/2"	Sch 40 S STD*	2,87	2,77	38,1	A	0,06		X	X	X
26,67	21,34	3/4"	1/2"	Sch 80 S XS*	3,91	3,73	38,1	A	0,08		X		X
26,67	21,34	3/4"	1/2"	Sch 160*	5,54	4,75	38,1	A	0,15		X		X
26,90	21,30				2,00	2,00	16,8	B	0,02			X	
28,00	18,00				1,50	1,50	30,0	B/D	0,02	X■			
33,40	21,34	1"	1/2"	Sch 10 S*	2,77	2,11	50,8	A	0,09	X	X	X	X
33,40	21,34	1"	1/2"	Sch 40 S STD*	3,38	2,77	50,8	A	0,11		X	X	X
33,40	21,34	1"	1/2"	Sch 80 S XS*	4,55	3,37	50,8	A	0,13		X		X
33,40	21,34	1"	1/2"	Sch 160*	6,35	4,75	50,8	A	0,22		X		X
33,40	26,67	1"	3/4"	Sch 10 S*	2,77	2,11	50,8	A	0,10	X	X	X	X
33,40	26,67	1"	3/4"	Sch 40 S STD*	3,38	2,87	50,8	A	0,12		X		X
33,40	26,67	1"	3/4"	Sch 80 S XS*	4,55	3,91	50,8	A	0,15		X		X
33,40	26,67	1"	3/4"	Sch 160*	6,35	5,54	50,8	A	0,22		X		X
33,70	21,30				2,00	2,00	37,3	B	0,5			X	
33,70	26,90				2,00	2,00	20,4	B	0,03			X	
38,10	25,40				1,50	1,50	97,0	B/D	0,02			X■□	
40,00	28,00				1,50	1,50	102,0	B/D	0,03			X■	
42,16	21,34	1.1/4"	1/2"	Sch 40 S STD*	3,56	2,77	50,8	A	0,13			X	X
42,16	21,34	1.1/4"	1/2"	Sch 80 S*	4,85	3,73	50,8	A	0,17				X
42,16	26,67	1.1/4"	3/4"	Sch 10 S*	2,77	2,11	50,8	A	0,11	X	X	X	X
42,16	26,67	1.1/4"	3/4"	Sch 40 S STD*	3,56	2,87	50,8	A	0,14		X		X
42,16	33,40	1.1/4"	1"	Sch 10 S*	2,77	2,77	50,8	A	0,12	X	X	X	X
42,16	33,40	1.1/4"	1"	Sch 40 S STD*	3,56	3,38	50,8	A	0,16				X
42,16	33,40	1.1/4"	1"	Sch 80 S XS*	4,85	4,55	50,8	A	0,21				X
42,40	33,70				2,00	2,00	26,1	B	0,07			X	
44,00	29,00				2,00	2,00	45,0	B	0,05			X	
48,26	21,34	1.1/2"	1/2"	Sch 10 S*	2,77	2,11	63,5	A	0,14		X	X	X
48,26	21,34	1.1/2"	1/2"	Sch 40 S STD*	3,68	2,77	63,5	A	0,18		X		X
48,26	21,34	1.1/2"	1/2"	Sch 80 S XS*	5,08	3,73	63,5	A	0,24		X		X
48,26	26,67	1.1/2"	3/4"	Sch 10 S*	2,77	2,11	63,5	A	0,15		X	X	X
48,26	26,67	1.1/2"	3/4"	Sch 40 S STD*	3,68	2,87	63,5	A	0,20		X		X
48,26	26,67	1.1/2"	3/4"	Sch 80 S XS*	5,08	3,91	63,5	A	0,27		X		X

Concentrische lasverloopstukken

Concentric reducers

Konzentrische Reduzierungen

Réductions concentriques

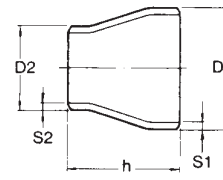

Norm-type A / ANSI

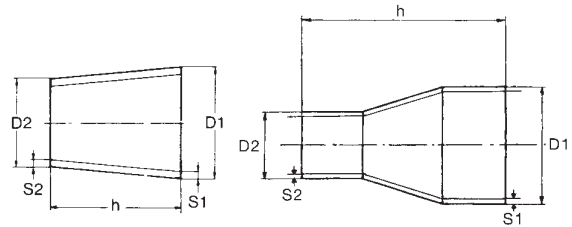

Norm-type B / DIN

Norm-type D / DIN

- = Gepolijst - Polished - Poliërt - Polis
- = Gebeitst - Pickled - Gebeitst - Décapés
- * = Afmeting vgl. ASME B 16.9, vervaardigd vlg. ASTM A403, afgeschuind vgl. ASME B 16.25
- * = Dimension to ASME B.16.9, produced ASTM A403, ends bevelled to ASME B16.25
- * = Abmessung nach ASME B 16.9, hergestellt nach ASTM A403, abgeSchrägt nach ASME B 16.25
- * = Dimension selon la norme ASME B.16.9, fabriqués selon la norme ASTM A403, extrémités chanfreinées selon la norme ASME B16.25

Omschrijving op pagina 41-43
Description on page 41-43
Umschreibung auf Seite 41-43
Description à la page 41-43

mm Afmeting mm Size mm Abmessung Dimension en mm		inch Afmeting inch Size inch Abmessung Dimension en pouces			S1	S2	h	Norm type	+/- Kg St./pc.	304L gelast welded geschw. soudés	304L naadloos seamless nahtlos. sans soudure	316L gelast welded geschw. soudés	316L naadloos seamless nahtlos. sans soudure
D1	D2	D1	D2										
48,26	33,40	1.1/2"	1"	Sch 10 S*	2,77	2,77	63,5	A	0,17	X	X	X	X
48,26	33,40	1.1/2"	1"	Sch 40 S STD*	3,68	3,38	63,5	A	0,22		X	X	X
48,26	33,40	1.1/2"	1"	Sch 80 S XS*	5,08	4,55	63,5	A	0,29		X		X
48,26	42,16	1.1/2"	1.1/4"	Sch 10 S*	2,77	2,77	63,5	A	0,18	X		X	X
48,26	42,16	1.1/2"	1.1/4"	Sch 40 S STD*	3,68	3,56	63,5	A	0,24			X	X
48,26	42,16	1.1/2"	1.1/4"	Sch 80 S XS*	5,08	4,85	63,5	A	0,32				X
48,30	33,70				2,00	2,00	43,8	B	0,09			X	
48,30	42,40				2,00	2,00	17,7	B	0,04			X	
50,80	25,40				1,50	1,50	115,0	B/D	0,1			X■□	
50,80	38,10				1,50	1,50	97,0	B/D	0,12			X■□	
52,00	28,00				1,50	1,50	130,0	B/D	0,07			X■	
52,00	40,00				1,50	1,50	113,0	B/D	0,09			X■□	
54,00	30,00				2,00	2,00	60,0	B	0,12			X	
54,00	34,00				2,00	2,00	72,0	B	0,11			X	
54,00	44,00				2,00	2,00	30,0	B	0,07			X	
60,30	21,30				2,00	2,00	117,0	B	0,23			X	
60,30	33,70				2,00	2,00	79,8	B	0,19			X	
60,30	42,40				2,00	2,00	53,7	B	0,14			X	
60,30	48,30				2,00	2,00	35,0	B	0,10			X	
60,33	21,34	2"	1/2"	Sch 10 S*	2,77	2,11	76,2	A	0,23		X	X	X
60,33	21,34	2"	1/2"	Sch 40 S STD*	3,91	2,77	76,2	A	0,28		X		X
60,33	26,67	2"	3/4"	Sch 10 S*	2,77	2,11	76,2	A	0,22	X		X	X
60,33	26,67	2"	3/4"	Sch 40 S STD*	3,91	2,87	76,2	A	0,30		X		X
60,33	26,67	2"	3/4"	Sch 80 S XS*	5,54	3,91	76,2	A	0,41		X		X
60,33	33,40	2"	1"	Sch 10 S*	2,77	2,77	76,2	A	0,23	X	X	X	X
60,33	33,40	2"	1"	Sch 40 S STD*	3,91	3,38	76,2	A	0,32		X	X	X
60,33	33,40	2"	1"	Sch 80 S XS*	5,54	4,55	76,2	A	0,44		X		X
60,33	33,40	2"	1"	Sch 160*	8,71	6,35	76,2	A	0,94				X
60,33	42,16	2"	1.1/4"	Sch 10 S*	2,77	2,77	76,2	A	0,25	X	X	X	X
60,33	42,16	2"	1.1/4"	Sch 40 S STD*	3,91	3,56	76,2	A	0,35		X		X
60,33	42,16	2"	1.1/4"	Sch 80 S XS*	5,54	4,85	76,2	A	0,48				X
60,33	48,26	2"	1.1/2"	Sch 10 S*	2,77	2,77	76,2	A	0,27	X	X	X	X
60,33	48,26	2"	1.1/2"	Sch 40 S STD*	3,91	3,68	76,2	A	0,37	X	X	X	X
60,33	48,26	2"	1.1/2"	Sch 80 S XS*	5,54	5,08	76,2	A	0,51		X		X
63,50	38,10				1,50	1,50	65,0	B/D	0,09			X■□	

Concentrische lasverloopstukken

Concentric reducers

Konzentrische Reduzierungen

Réductions concentriques

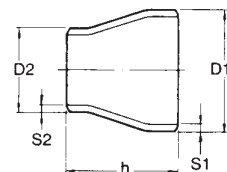

Norm-type A / ANSI

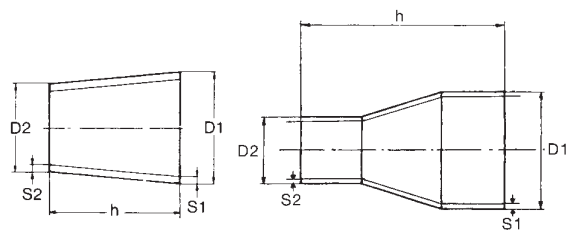

Norm-type B / DIN

Norm-type D / DIN

- = Gepolijst - Polished - Poliirt - Polis
- = Gebeitst - Pickled - Gebeizt - Décapés
- * = Afmeting vgl. ASME B 16.9, vervaardigd vlg. ASTM A403, afgeschuind vgl. ASME B 16.25
- * = Dimension to ASME B.16.9, produced ASTM A403, ends bevelled to ASME B16.25
- * = Abmessung nach ASME B 16.9, hergestellt nach ASTM A403, abgeSchrägt nach ASME B 16.25
- * = Dimension selon la norme ASME B.16.9, fabriqués selon la norme ASTM A403, extrémités chanfreinées selon la norme ASME B16.25

Omschrijving op pagina 41-43
 Description on page 41-43
 Umschreibung auf Seite 41-43
 Description à la page 41-43

mm Afmeting mm Size mm Abmessung Dimension en mm		inch Afmeting inch Size inch Abmessung Dimension en pouces								304L	304L	316L	316L
D1	D2	D1	D2	S1	S2	h	Norm type	+/- Kg St./pc.	gelast welded geschw. soudés	naadloos seamless nahtlos. sans soudure	gelast welded geschw. soudés	naadloos seamless nahtlos. sans soudure	
63,50	50,80			1,50	1,50	97,0	B/D	0,13				X■□	
69,00	54,00			2,00	2,00	45,0	B	0,13				X	
70,00	40,00			1,50	1,50	117,0	B/D	0,15				X□	
70,00	52,00			1,50	1,50	135,0	B/D	0,15				X■	
73,03	33,40	2.1/2"	1"	Sch 10 S*	3,05	2,77	88,9	A	0,35				X
73,03	48,26	2.1/2"	1.1/2"	Sch 10 S*	3,05	2,77	88,9	A	0,39	X	X	X	X
73,03	48,26	2.1/2"	1.1/2"	Sch 40 S STD*	5,16	3,68	88,9	A	0,66	X	X		X
73,03	60,33	2.1/2"	2"	Sch 10 S*	3,05	2,77	88,9	A	0,43	X	X	X	X
73,03	60,33	2.1/2"	2"	Sch 40 S STD*	5,16	3,91	88,9	A	0,72		X		X
73,03	60,33	2.1/2"	2"	Sch 80 S XS*	7,01	5,54	88,9	A	0,92				X
76,10	33,70				2,00	2,00	127,2	B	0,26			X	
76,10	38,10				1,50	1,50	132,0	B/D	0,26			X■□	
76,10	42,40				2,00	2,00	101,1	B	0,26			X	
76,10	42,40				2,50	2,50	101,1	B	0,39			X	
76,10	48,30				2,00	2,00	83,4	B	0,26			X	
76,10	48,30				3,00	3,00	83,4	B	0,35			X	
76,10	50,80				1,50	1,50	115,0	B/D	0,26			X■□	
76,10	60,30				2,00	2,00	47,4	B	0,16			X	
76,10	60,30				3,00	3,00	47,4	B	0,24			X	
76,10	63,50				1,50	1,50	97,0	B/D	0,16	X■		X■□	
84,00	44,50				2,00	2,00	120,0	B	0,45			X	
84,00	54,00				2,00	2,00	90,0	B	0,30			X	
84,00	69,00				2,00	2,00	45,0	B	0,17			X	
88,90	33,40	3"	1"	Sch 10 S*	3,05	2,77	88,9	A	0,43	X		X	X
88,90	33,40	3"	1"	Sch 40 S STD*	5,49	3,38	88,9	A	0,74		X		X
88,90	33,40	3"	1"	Sch 80 S XS*	7,62	4,55	88,9	A	0,83				X
88,90	42,16	3"	1.1/4"	Sch 10 S*	3,05	2,77	88,9	A	0,40			X	X
88,90	48,26	3"	1.1/2"	Sch 10 S*	3,05	2,77	88,9	A	0,45	X	X	X	X
88,90	48,26	3"	1.1/2"	Sch 40 S STD*	5,49	3,68	88,9	A	0,78		X	X	X
88,90	48,26	3"	1.1/2"	Sch 80 S XS*	7,62	5,08	88,9	A	0,43		X		X
88,90	48,30				2,00	2,00	121,8	B	1,04			X	
88,90	60,30				2,00	2,00	85,8	B	0,32			X	
88,90	60,33	3"	2"	Sch 10 S*	3,05	2,77	88,9	A	0,48	X	X	X	X
88,90	60,33	3"	2"	Sch 40 S STD*	5,49	3,91	88,9	A	0,85		X	X	X
88,90	60,33	3"	2"	Sch 80 S XS*	7,62	5,54	88,9	A	1,13		X		X

Concentrische lasverloopstukken

Concentric reducers

Konzentrische Reduzierungen

Réductions concentriques

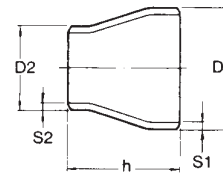

Norm-type A / ANSI

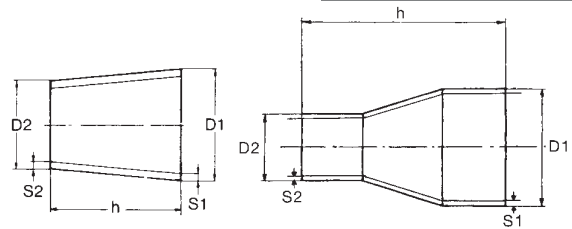

Norm-type B / DIN

Norm-type D / DIN

- = Gepolijst - Polished - Poliirt - Polis
- = Gebeitst - Pickled - Gebeitst - Décapés
- * = Afmeting vgl. ASME B 16.9, vervaardigd vlg. ASTM A403, afgeschuind vgl. ASME B 16.25
- * = Dimension to ASME B.16.9, produced ASTM A403, ends bevelled to ASME B16.25
- * = Abmessung nach ASME B 16.9, hergestellt nach ASTM A403, abgeSchrägt nach ASME B 16.25
- * = Dimension selon la norme ASME B.16.9, fabriqués selon la norme ASTM A403, extrémités chanfreinées selon la norme ASME B16.25

Omschrijving op pagina 41-43
Description on page 41-43
Umschreibung auf Seite 41-43
Description à la page 41-43

mm Afmeting mm Size mm Abmessung Dimension en mm		inch Afmeting inch Size inch Abmessung Dimension en pouces			S1	S2	h	Norm type	+/- Kg St./pc.	304L gelast welded geschw. soudés	304L naadloos seamless nahtlos. sans soudure	316L gelast welded geschw. soudés	316L naadloos seamless nahtlos. sans soudure
D1	D2	D1	D2										
88,90	60,33	3"	2"	Sch 160*	11,13	8,71	88,9	A	0,16		X		X
88,90	73,03	3"	2.1/2"	Sch 10 S*	3,05	3,05	88,9	A	0,52	X	X	X	X
88,90	73,03	3"	2.1/2"	Sch 40 S STD*	5,49	5,16	88,9	A	0,93	X	X		X
88,90	73,03	3"	2.1/2"	Sch 80 S XS*	7,62	7,01	88,9	A	2,23		X		X
88,90	76,10				2,00	2,00	38,4	B	0,16			X	
88,90	76,10				3,00	3,00	38,4	B	1,23			X	
101,60	50,80				1,50	1,50	73,0	B/D	0,35			X■□	
101,60	63,50				1,50	1,50	56,0	B/D	0,32			X■□	
101,60	76,10				1,50	1,50	35,5	B/D	0,30			X■	
104,00	54,00				2,00	2,00	150,0	B	0,44			X	
104,00	69,00				2,00	2,00	105,0	B	0,37			X	
104,00	84,00				2,00	2,00	60,0	B	0,27			X	
114,30	48,26	4"	1.1/2"	Sch 10 S*	3,05	2,77	101,6	A	0,63		X	X	X
114,30	48,26	4"	1.1/2"	Sch 40 S STD*	6,02	3,68	101,6	A	1,18		X		X
114,30	60,30				2,00	2,00	162,0	B	0,45			X	
114,30	60,33	4"	2"	Sch 10 S*	3,05	2,77	101,6	A	0,67	X	X	X	X
114,30	60,33	4"	2"	Sch 40 S STD*	6,02	3,91	101,6	A	1,27	X	X	X	X
114,30	60,33	4"	2"	Sch 80 S XS*	8,56	5,54	101,6	A	1,76				X
114,30	73,03	4"	2.1/2"	Sch 10 S*	3,05	3,05	101,6	A	0,71	X	X	X	X
114,30	73,03	4"	2.1/2"	Sch 40 S STD*	6,02	5,16	101,6	A	1,37		X	X	X
114,30	76,10				2,00	2,00	114,6	B	0,55			X	
114,30	76,10				3,00	3,00	114,6	B	0,90			X	
114,30	88,90				2,00	2,00	76,2	B	0,39			X	
114,30	88,90	4"	3"	Sch 10 S*	3,05	3,05	101,6	A	0,76	X	X	X	X
114,30	88,90	4"	3"	Sch 40 S STD*	6,02	5,49	101,6	A	1,45	X	X	X	X
114,30	88,90	4"	3"	Sch 80 S XS*	8,56	7,62	101,6	A	2,02		X		X
129,00	69,00				2,00	2,00	180,0	B	0,85			X	
129,00	84,00				2,00	2,00	135,0	B	0,70			X	
129,00	104,00				2,00	2,00	75,0	B	0,43			X	
139,70	76,10				3,00	3,00	190,8	B	1,50			X	
139,70	88,90				2,00	2,00	152,4	B	0,88			X	
139,70	88,90				3,00	3,00	152,4	B	1,10			X	
139,70	114,30				2,00	2,00	76,2	B	0,49			X	
139,70	114,30				3,00	3,00	76,2	B	0,74			X	
141,30	73,03	5"	2.1/2"	Sch 10 S*	3,40	3,05	127,0	A	2,00		X	X	

Concentrische lasverloopstukken

Concentric reducers

Konzentrische Reduzierungen

Réductions concentriques

Omschrijving op pagina 41-43
Description on page 41-43
Umschreibung auf Seite 41-43
Description à la page 41-43

- = Gepolijst - Polished - Poliirt - Polis
- = Gebeitst - Pickled - Gebeizt - Décapés
- * = Afmeting vgl. ASME B 16.9, vervaardigd vlg. ASTM A403, afgeschuind vgl. ASME B 16.25
- * = Dimension to ASME B.16.9, produced ASTM A403, ends bevelled to ASME B16.25
- * = Abmessung nach ASME B 16.9, hergestellt nach ASTM A403, abgeSchrägt nach ASME B 16.25
- * = Dimension selon la norme ASME B.16.9, fabriqués selon la norme ASTM A403, extrémités chanfreinées selon la norme ASME B16.25

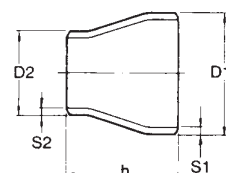

Norm-type A / ANSI

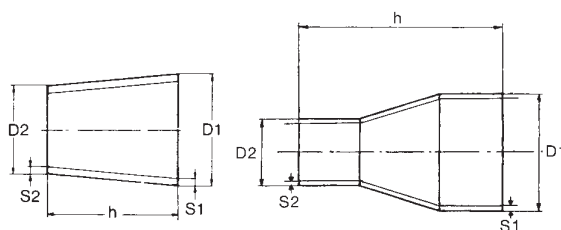

Norm-type B / DIN

Norm-type D / DIN

mm Afmeting		inch Afmeting			S1	S2	h	Norm type	+/- Kg St./pc.	304L	304L	316L	316L
mm Size	inch Size	mm Abmessung	inch Abmessung							gelast welded geschw. soudés	naadloos seamless nahtlos. sans soudure	gelast welded geschw. soudés	naadloos seamless nahtlos. sans soudure
D1	D2	D1	D2	Dimension en mm	Dimension en pouces								
141,30	88,90	5"	3"	Sch 10 S*	3,40	3,05	127,0	A	1,22			X	X
141,30	88,90	5"	3"	Sch 40 S STD*	6,55	5,49	127,0	A	2,27		X		X
141,30	114,30	5"	4"	Sch 10 S*	3,40	3,05	127,0	A	1,33	X	X	X	X
141,30	114,30	5"	4"	Sch 40 S STD*	6,55	6,02	127,0	A	2,50	X	X		X
154,00	84,00				2,00	2,00	210,0	B	1,22			X	
154,00	104,00				2,00	2,00	150,0	B	0,95			X	
154,00	129,00				2,00	2,00	75,0	B	0,52			X	
168,28	88,90	6"	3"	Sch 10 S*	3,40	3,05	140,0	A	1,53	X	X	X	X
168,28	88,90	6"	3"	Sch 40 S STD*	7,11	5,49	140,0	A	3,04	X	X	X	X
168,28	88,90	6"	3"	Sch 80 S XS*	10,97	7,62	140,0	A	4,56		X		X
168,28	114,30	6"	4"	Sch 10 S*	3,40	3,05	140,0	A	1,65	X	X	X	X
168,28	114,30	6"	4"	Sch 40 S STD*	7,11	6,02	140,0	A	3,30	X	X	X	X
168,28	114,30	6"	4"	Sch 80 S XS*	10,97	8,56	140,0	A	4,96		X		X
168,28	141,30	6"	5"	Sch 10 S*	3,40	3,40	140,0	A	1,78	X		X	X
168,28	141,30	6"	5"	Sch 40 S STD*	7,11	6,55	140,0	A	3,57		X		X
168,30	88,90				2,00	2,00	238,2	B	1,00			X	
168,30	114,30				2,00	2,00	162,0	B	1,16			X	
168,30	114,30				3,00	3,00	162,0	B	1,70			X	
168,30	139,70				2,00	2,00	85,8	B	0,84			X	
168,30	139,70				3,00	3,00	85,8	B	1,00			X	
204,00	104,00				2,00	2,00	300,0	B	2,28			X	
204,00	129,00				2,00	2,00	225,0	B	1,85			X	
204,00	154,00				2,00	2,00	150,0	B	1,33			X	
219,08	114,30	8"	4"	Sch 10 S*	3,76	3,05	152,4	A	2,43	X	X	X	X
219,08	114,30	8"	4"	Sch 40 S STD*	8,18	6,02	152,4	A	5,10	X	X	X	X
219,08	141,30	8"	5"	Sch 10 S*	3,76	3,40	152,4	A	5,40	X		X	X
219,08	168,30	8"	6"	Sch 10 S*	3,76	3,40	152,4	A	2,72	X	X	X	X
219,08	168,30	8"	6"	Sch 40 S STD*	8,18	7,11	152,4	A	5,71	X	X	X	X
219,10	114,30				2,00	2,00	314,4	B	2,10			X	
219,10	139,70				3,00	3,00	238,2	B	3,90			X	
219,10	168,30				3,00	3,00	152,4	B	2,20			X	
254,00	154,00				2,00	2,00	300,0	B	3,04			X	
254,00	204,00				2,00	2,00	150,0	B	1,71			X	
256,00	206,00				3,00	3,00	150,0	B	2,55			X	

Concentrische lasverloopstukken

Concentric reducers

Konzentrische Reduzierungen

Réductions concentriques

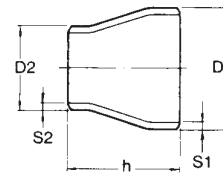

Norm-type A / ANSI

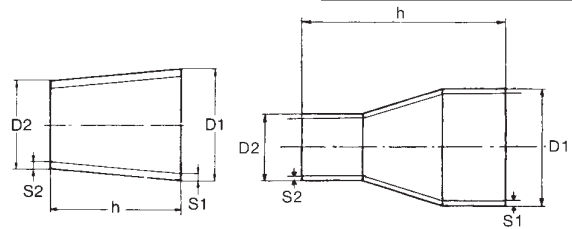

Norm-type B / DIN

Norm-type D / DIN

- = Gepolijst - Polished - Poliirt - Polis
- = Gebeitst - Pickled - Gebeitst - Décapés
- * = Afmeting vgl. ASME B 16.9, vervaardigd vlg. ASTM A403, afgeschuind vgl. ASME B 16.25
- * = Dimension to ASME B.16.9, produced ASTM A403, ends bevelled to ASME B16.25
- * = Abmessung nach ASME B 16.9, hergestellt nach ASTM A403, abgeSchrägt nach ASME B 16.25
- * = Dimension selon la norme ASME B.16.9, fabriqués selon la norme ASTM A403, extrémités chanfreinées selon la norme ASME B16.25

Omschrijving op pagina 41-43
Description on page 41-43
Umschreibung auf Seite 41-43
Description à la page 41-43

mm Afmeting mm Size mm Abmessung Dimension en mm		inch Afmeting inch Size inch Abmessung Dimension en pouces								304L	304L	316L	316L
D1	D2	D1	D2	S1	S2	h	Norm type	+/- Kg St./pc.	gelast welded geschw. soudés	naadloos seamless nahtlos. sans soudure	gelast welded geschw. soudés	naadloos seamless nahtlos. sans soudure	
273,00	168,30			3,00	3,00	314,1	B	5,27				X	
273,00	219,10			3,00	3,00	161,7	B	3,00				X	
273,05	114,30	10"	4"	4,19	3,05	177,8	A	3,80				X	
273,05	168,28	10"	6"	4,19	3,40	177,8	A	4,14	X			X	X
273,05	168,28	10"	6"	9,27	7,11	177,8	A	8,78	X	X		X	X
273,05	219,08	10"	8"	4,19	3,76	177,8	A	4,49	X	X		X	X
273,05	219,08	10"	8"	9,27	8,18	177,8	A	9,58	X	X		X	X
304,00	204,00			2,00	2,00	300,0	B	5,00				X	
304,00	254,00			2,00	2,00	150,0	B	4,80				X	
306,00	206,00			3,00	3,00	300,0	B	5,70				X	
323,85	168,28	12"	6"	4,57	3,40	203,0	A	5,92	X			X	
323,85	219,08	12"	8"	4,57	3,76	203,0	A	6,31	X			X	
323,85	219,08	12"	8"	9,53	8,18	203,0	A	3,46	X			X	
323,85	273,05	12"	10"	4,52	4,19	203,2	A	12,70	X			X	X
323,85	273,05	12"	10"	9,53	9,27	203,2	A	13,60	X	X		X	X
323,90	168,30			3,00	3,00	466,8	B	6,70				X	
323,90	219,10			3,00	3,00	314,8	B	6,40				X	
323,90	273,00			3,00	3,00	152,7	B	6,40				X	
355,60	219,10			3,00	3,00	409,5	B	6,50				X	
355,60	273,00			3,00	3,00	247,8	B	5,90				X	
355,60	273,05	14"	10"	4,78	4,19	330,2	A	12,10	X			X	
355,60	323,90			3,00	3,00	95,1	B	2,40				X	
355,60	323,85	14"	12"	4,78	4,57	330,2	A	13,00	X			X	
356,00	306,00			3,00	3,00	150,0	B	3,70				X	
406,00	273,00			3,00	3,00	400,2	B	8,50				X	
406,00	306,00			3,00	3,00	300,0	B	7,96				X	
406,00	356,00			3,00	3,00	150,0	B	4,26				X	
406,40	273,05	16"	10"	4,78	4,19	355,6	A	14,4	X			X	
406,40	323,85	16"	12"	4,78	4,57	355,6	A	15,20	X			X	
406,40	323,85	16"	12"	9,53	9,53	355,6	A	29,60				X	
406,40	355,60	16"	14"	4,78	4,78	508,0	A	15,80	X			X	
506,00	356,00			3,00	3,00	457,2	B	15,00				X	
506,00	406,00			3,00	3,00	300,0	B	11,00				X	

Excentrische lasverloopstukken

Excentric reducers

Exzentrische Reduzierungen

Réductions excentriques

Excentrische lasverloopstukken

gelast en naadloos

Excentric reducers

welded and seamless

Exzentrische Reduzierungen

geschweisst und nahtlos

Réductions excentriques

soudés et sans soudures

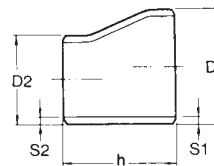

Norm-type A / ANSI

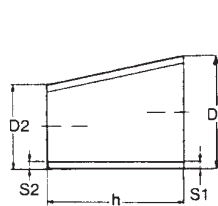

Norm-type B / DIN

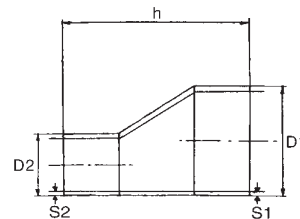

Norm-type D / DIN

- = Gepolijst - Polished - Poliërt - Polis
- = Gebeitst - Pickled - Gebeitst - Décapés
- * = Afmeting vgl. ASME B 16.9, vervaardigd vlg. ASTM A403, afgeschuind vgl. ASME B 16.25
- * = Dimension to ASME B.16.9, produced ASTM A403, ends bevelled to ASME B16.25
- * = Abmessung nach ASME B 16.9, hergestellt nach ASTM A403, abgeSchrägt nach ASME B 16.25
- * = Dimension selon la norme ASME B.16.9, fabriqués selon la norme ASTM A403, extrémités chanfreinées selon la norme ASME B16.25

Omschrijving op pagina 41-43
Description on page 41-43
Umschreibung auf Seite 41-43
Description à la page 41-43

mm Afmeting		inch Afmeting			S1	S2	h	Norm type	+/- Kg St./pc.	304L	304L	316L	316L
mm Size	mm Abmessung	inch Size	inch Abmessung							gelast welded geschw. soudés	naadloos seamless nahtlos. sans soudure	gelast welded geschw. soudés	naadloos seamless nahtlos. sans soudure
D1	D2	D1	D2										
26,67	21,34	3/4"	1/2"	Sch 40 S STD*	2,87	2,77	38,1	A	0,06				X
33,40	21,34	1"	1/2"	Sch 10 S*	2,77	2,11	50,8	A	0,09	X	X	X	X
33,40	21,34	1"	1/2"	Sch 40 S STD*	3,38	2,77	50,8	A	0,11	X	X		X
33,40	21,34	1"	1/2"	Sch 80 S XS*	4,55	3,73	50,8	A	0,13		X		X
33,40	26,67	1"	3/4"	Sch 80 S*	4,55	3,91	50,8	A	0,15				X
42,16	26,67	1.1/4"	3/4"	Sch 40 S STD*	3,56	2,87	50,8	A	0,14			X	
42,16	33,40	1.1/4"	1"	Sch 10 S*	2,77	2,77	50,8	A	0,12	X			X
42,16	33,40	1.1/4"	1"	Sch 40 S*	3,56	3,38	50,8	A	0,16			X	
48,26	26,67	1.1/2"	3/4"	Sch 10 S*	2,77	2,11	63,5	A	0,15		X		X
48,26	26,67	1.1/2"	3/4"	Sch 40 S STD*	3,68	2,87	63,5	A	0,20		X		X
48,26	26,67	1.1/2"	3/4"	Sch 80 S*	5,08	3,91	63,5	A	0,27				X
48,26	33,40	1.1/2"	1"	Sch 10 S*	2,77	2,77	63,5	A	0,17		X	X	X
48,26	33,40	1.1/2"	1"	Sch 40 S STD*	3,68	3,38	63,5	A	0,22		X	X	X
48,26	33,40	1.1/2"	1"	Sch 80 S XS*	5,08	4,55	63,5	A	0,29				X
48,26	42,16	1.1/2"	1.1/4"	Sch 10 S*	2,77	2,77	63,5	A	0,18		X	X	
48,30	33,70				2,00	2,00	43,8	B	0,09			X	
50,80	38,10				1,50	1,50	38,1	B/D	0,12			X■	
60,30	21,30				2,00	2,00	117,0	B	0,25			X	
60,30	33,70				2,00	2,00	79,8	B	0,24			X	
60,30	48,30				2,00	2,00	36,0	B	0,10			X	
60,33	26,67	2"	3/4"	Sch 10 S*	2,77	2,11	76,2	A	0,22		X	X	
60,33	26,67	2"	3/4"	Sch 80 S XS*	5,54	3,91	76,2	A	0,41				X
60,33	33,40	2"	1"	Sch 10 S*	2,77	2,77	76,2	A	0,23		X	X	X
60,33	33,40	2"	1"	Sch 40 S STD*	3,91	3,38	76,2	A	0,32		X		X
60,33	33,40	2"	1"	Sch 80 S XS*	5,54	4,55	76,2	A	0,44		X		X
60,33	33,40	2"	1"	Sch 160	8,71	6,35	76,2	A	0,94		X		
60,33	42,16	2"	1.1/4"	Sch 10 S*	2,77	2,77	76,2	A	0,25			X	
60,33	48,26	2"	1.1/2"	Sch 10 S*	2,77	2,77	76,2	A	0,27	X	X	X	X
60,33	48,26	2"	1.1/2"	Sch 40 S STD*	3,91	3,68	76,2	A	0,37		X		X
60,33	48,26	2"	1.1/2"	Sch 80 S XS*	5,54	5,08	76,2	A	0,51				X
73,03	48,26	2.1/2"	1.1/2"	Sch 10 S*	3,05	2,77	88,9	A	0,39				X
73,03	60,33	2.1/2"	2"	Sch 10 S*	3,05	2,77	88,9	A	0,43	X	X		
76,10	48,30				2,00	2,00	83,4	B	0,26			X	
76,10	60,30				2,00	2,00	47,4	B	0,16			X	
84,00	54,00				2,00	2,00	88,9	B	0,30			X	

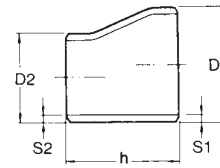

Norm-type A / ANSI

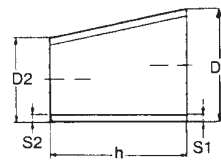

Norm-type B / DIN

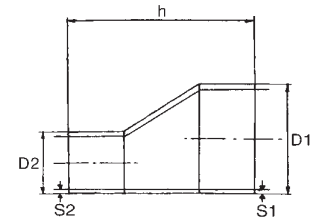

Norm-type D / DIN

- = Gepolijst - Polished - Poliërt - Polis
- = Gebeitst - Pickled - Gebeitst - Décapés
- * = Afmeting vgl. ASME B 16.9, vervaardigd vlg. ASTM A403, afgeschuind vgl. ASME B 16.25
- * = Dimension to ASME B.16.9, produced ASTM A403, ends bevelled to ASME B16.25
- * = Abmessung nach ASME B 16.9, hergestellt nach ASTM A403, abgeSchrägt nach ASME B 16.25
- * = Dimension selon la norme ASME B.16.9, fabriqués selon la norme ASTM A403, extrémités chanfreinées selon la norme ASME B16.25

Omschrijving op pagina 41-43
Description on page 41-43
Umschreibung auf Seite 41-43
Description à la page 41-43

mm Afmeting mm Size mm Abmessung Dimension en mm		inch Afmeting inch Size inch Abmessung Dimension en pouces								304L	304L	316L	316L
D1	D2	D1	D2	S1	S2	h	Norm type	+/- Kg St./pc.		gelast welded geschw. soudés	naadloos seamless nahtlos. sans soudure	gelast welded geschw. soudés	naadloos seamless nahtlos. sans soudure
84,00	69,00			2,00	2,00	45,0	B	0,17				X	
88,90	33,40	3"	1"	Sch 10 S*	3,05	2,77	88,9	A	0,43				X
88,90	42,40				2,00	2,00	139,5	B	0,43			X	
88,90	48,26	3"	1.1/2"	Sch 10 S*	3,05	2,77	88,9	A	0,45		X	X	X
88,90	48,26	3"	1.1/2"	Sch 40 S STD*	5,49	3,68	88,9	A	0,78		X		X
88,90	48,26	3"	1.1/2"	Sch 80 S XS*	7,62	5,08	88,9	A	0,46				X
88,90	60,30				2,00	2,00	85,8	B	0,32			X	
88,90	60,33	3"	2"	Sch 10 S*	3,05	2,77	88,9	A	0,48	X	X	X	X
88,90	60,33	3"	2"	Sch 40 S STD*	5,49	3,91	88,9	A	0,85		X		X
88,90	60,33	3"	2"	Sch 80 S XS*	7,62	5,54	88,9	A	1,18		X		X
88,90	73,03	3"	2.1/2"	Sch 10 S*	3,05	3,05	88,9	A	0,52		X	X	X
88,90	73,03	3"	2.1/2"	Sch 40 S STD*	5,49	5,16	88,9	A	0,93				X
88,90	76,10				3,00	3,00	38,4	B	0,16			X	
104,00	69,00				2,00	2,00	105,0	B	0,37			X	
104,00	84,00				2,00	2,00	60,0	B	0,27			X	
114,30	48,26	4"	1.1/2"	Sch 10 S*	3,05	2,77	101,6	A	0,63		X		X
114,30	60,30				2,00	2,00	162,0	B	0,71			X	
114,30	60,33	4"	2"	Sch 10 S*	3,05	2,77	101,6	A	0,67	X	X	X	X
114,30	60,33	4"	2"	Sch 40 S STD*	6,02	3,91	101,6	A	1,27		X		X
114,30	73,03	4"	2.1/2"	Sch 10 S*	3,05	3,05	101,6	A	0,71		X	X	X
114,30	76,10				2,00	2,00	114,6	B	0,55			X	
114,30	88,90				2,00	2,00	76,2	B	0,39			X	
114,30	88,90	4"	3"	Sch 10 S*	3,05	3,05	101,6	A	0,76		X	X	X
114,30	88,90	4"	3"	Sch 40 S STD*	6,02	5,49	101,6	A	1,45		X		X
129,00	84,00				2,00	2,00	135,0	B	0,70			X	
129,00	104,00				2,00	2,00	75,0	B	0,43			X	
139,70	76,10				2,00	2,00	190,8	B	1,04			X	
139,70	88,90				2,00	2,00	152,4	B	0,88			X	
139,70	114,30				2,00	2,00	76,2	B	0,49			X	
139,70	114,30				3,00	3,00	76,2	B	0,74			X	
141,30	88,90	5"	3"	Sch 10 S*	3,40	3,05	127,0	A	1,22	X			
141,30	114,30	5"	4"	Sch 10 S*	3,40	3,05	127,0	A	1,33			X	
154,00	84,00				2,00	2,00	210,0	B	1,22			X	
154,00	104,00				2,00	2,00	150,0	B	0,96			X	
154,00	129,00				2,00	2,00	75,0	B	0,52			X	

Excentrische lasverloopstukken

Excentric reducers

Exzentrische Reduzierungen

Réductions excentriques

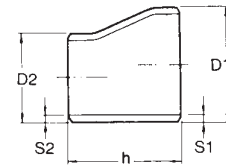

Norm-type A / ANSI

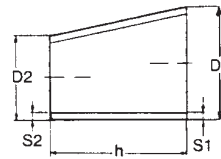

Norm-type B / DIN

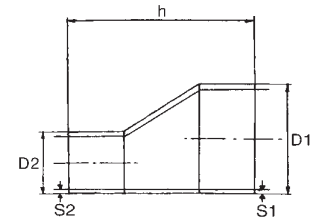

Norm-type D / DIN

- = Gepolijst - Polished - Poliërt - Polis
- = Gebeitst - Pickled - Gebeitst - Décapés
- * = Afmeting vgl. ASME B 16.9, vervaardigd vgl. ASTM A403, afgeschuind vgl. ASME B 16.25
- * = Dimension to ASME B.16.9, produced ASTM A403, ends bevelled to ASME B16.25
- * = Abmessung nach ASME B 16.9, hergestellt nach ASTM A403, abgeSchrägt nach ASME B 16.25
- * = Dimension selon la norme ASME B.16.9, fabriqués selon la norme ASTM A403, extrémités chanfreinées selon la norme ASME B16.25

Omschrijving op pagina 41-43
Description on page 41-43
Umschreibung auf Seite 41-43
Description à la page 41-43

mm Afmeting		inch Afmeting			S1	S2	h	Norm type	+/- Kg St./pc.	304L	304L	316L	316L
mm Size	inch Size	mm Abmessung	inch Abmessung							gelast welded geschw. soudés	naadloos seamless nahtlos. sans soudure	gelast welded geschw. soudés	naadloos seamless nahtlos. sans soudure
D1	D2	D1	D2	Dimension en mm	Dimension en pouces								
168,28	88,90	6"	3"	Sch 10 S*	3,40	3,05	152,4	A	1,53		X	X	X
168,28	88,90	6"	3"	Sch 40 S STD*	7,11	5,49	152,4	A	3,04		X		X
168,28	114,30	6"	4"	Sch 10 S*	3,40	3,05	152,4	A	1,65	X	X	X	X
168,28	114,30	6"	4"	Sch 40 S STD*	7,11	6,02	152,4	A	3,30		X		X
168,28	114,30	6"	4"	Sch 80 S	10,97	8,56	140,0	A	5,45		X		
168,28	141,30	6"	5"	Sch 10 S*	3,40	3,40	152,4	A	1,78		X	X	X
168,30	114,30				2,00	2,00	162,0	B	0,96			X	
168,30	139,70				3,00	3,00	85,0	B	1,00			X	
204,00	104,00				2,00	2,00	300,0	B	2,28			X	
204,00	129,00				2,00	2,00	225,0	B	1,85			X	
204,00	154,00				2,00	2,00	150,0	B	1,33			X	
219,08	114,30	8"	4"	Sch 10 S*	3,76	3,05	152,4	A	2,43	X	X	X	X
219,08	141,30	8"	5"	Sch 10 S*	3,76	3,40	152,4	A	2,58	X	X		X
219,08	168,28	8"	6"	Sch 10 S*	3,76	3,40	152,4	A	2,72	X	X	X	X
219,08	168,28	8"	6"	Sch 40 S STD*	8,18	7,11	152,4	A	5,71	X	X	X	X
219,10	114,30				2,00	2,00	314,4	B	2,10			X	
254,00	204,00				2,00	2,00	150,0	B	3,04			X	
273,00	168,30				3,00	3,00	314,1	B	5,27			X	
273,00	219,10				3,00	3,00	161,7	B	3,02			X	
273,05	168,30	10"	6"	Sch 10 S*	4,19	3,40	177,8	A	4,14	X		X	
273,05	219,10	10"	8"	Sch 10 S*	4,19	3,76	177,8	A	4,49	X		X	
273,05	219,10	10"	8"	Sch 40 S STD*	9,27	8,18	177,8	A	9,58	X	X	X	X
323,85	219,08	12"	8"	Sch 10 S*	4,57	3,76	203,2	A	6,31	X		X	
323,85	273,05	12"	10"	Sch 10 S*	4,57	4,19	203,2	A	6,78	X		X	
323,90	168,30				3,00	3,00	466,8	B	8,73			X	
323,90	219,10				3,00	3,00	314,4	B	6,49			X	
355,60	273,05	14"	10"	Sch 10 S*	4,78	4,19	330,2	A	12,10	X			
406,40	273,05	16"	10"	Sch 10 S*	4,78	4,19	355,6	A	14,4	X			
406,40	323,90	16"	12"	Sch 10 S*	4,78	4,57	355,6	A	15,20	X		X	

T-stukken

Tees

T-Stücke

Tes

T-stukken

Tees

T-Stücke

Tes

Spec. 001

Gelaste T-stukken volgens ASTM A403 en ASME B16.9.

Keuringsrapport volgens EN 10204/3.1 van zowel het T-stuk als het basismateriaal.

Alle T-stukken 100% op materiaalverwisseling getest.

T-stukken tweevoudig gecertificeerd.

Welded tees acc. to ASTM A403 and ASME B16.9.

Inspection certificate as per EN 10204/3.1 for the tee and the base material.

All tees 100 % PMI- tested.

Tees dual certified.

Geschweisste T-Stücke nach ASTM A403 und ASME B16.9.

Abnahmeprüfzeugnis nach EN 10204/3.1 für T-Stück und Grundwerkstoff.

Alle T-Stücke mit 100% Verwechslungsprüfung.

T-Stücke zweifach zertifiziert.

Tes soudés conformes aux normes ASTM A403 et ASME B16.9.

Certificat d'inspection selon la norme EN 10204/3.1, pour le te et la matière de base.

Tous les tes ont été soumis à un test PMI à 100 %.

Double certification.

Spec. 002

Naadloze T-stukken volgens ASTM A403 en ASME B16.9.

Keuringsrapport volgens EN 10204/3.1 van zowel het T-stuk als het basismateriaal.

Alle T-stukken aanvullend getest op interkristallijne corrosie volgens ASTM A262 pr.E en PMI d.m.v.spectrograph.

Hardheid HRC 22 max. volgens NACE MR01-75 laatste uitgave.

T-stukken tweevoudig gecertificeerd.

Seamless tees acc. to ASTM A403 and ASME B16.9.

Inspection certificate as per EN 10204/3.1 for the tee and the base material.

All tees additionally tested on intergranular corrosion acc. to ASTM A262 pr.E and PMI-tested by spectrograph.

Hardness HRC 22 max. acc. to NACE MR01-75 latest edition.

Tees dual certified.

Nahtlose T-Stücke nach ASTM A403 und ASME B16.9.

Abnahmeprüfzeugnis nach EN 10204/3.1 für T-Stück und Grundwerkstoff.

Alle T-Stücke zusätzlich geprüft auf Interkristalline Korrosion nach ASTM A262 pr.E und mit Verwechslungsprüfung durch Spectrograph.

Härte HRC max. 22 nach NACE MR01-75 letzte Ausgabe.

T-Stücke zweifach zertifiziert.

Tes sans soudure conformes aux normes ASTM A403 et ASME B16.9.

Certificat d'inspection selon la norme EN 10204/3.1, pour le te et la matière de base.

Tous les tes sont également testés pour leur corrosion intergranulaire, conformément à la norme ASTM A262 pr. E et ont été soumis à un test PMI par spectrographe.

Dureté HRC 22 max., conformément à la norme NACE MR01-75 (dernière édition).

Double certification.

Een groot deel van ons assortiment naadloze fittingen is ook leverbaar van door STOOMWEZEN goedgekeurde leveranciers

A major part of our stockprogramme seamless fittings is also available from STOOMWEZEN approved suppliers

Einen grossen Teil aus unserem nahtlosen Fittingsortiment können wir auch nach STOOMWEZEN-anerkannten Lieferanten liefern.

La plupart des raccords sans soudure de notre gamme sont également disponibles et fabriqués par des fournisseurs agréés « STOOMWEZEN ».

Spec. 003

Gelaste T-stukken korte aftakking. Interkristallijne corrosietest volgens DIN 50914 of NF A 05-159.

Keuringsrapport volgens EN 10204/3.1.

Welded tees without branch. Intergranular corrosion test acc. to DIN 50914 or NF A 05-159.

Inspection certificate as per EN 10204/3.1.

Geschweisste T-Stücke ohne Abzweig. Interkristalline Korrosion Prüfung nach DIN 50914 oder NF A 05-159. Abnahmeprüfzeugnis nach EN 10204/3.1.

Tes soudés extrudés. Test de corrosion intergranulaire conforme à la norme DIN 50914 ou NF A 05-159.

Certificat d'inspection selon la norme EN 10204/3.1.

Spec. 004

Gelaste zuivel T-stukken volgens DIN 11852. Oppervlak uitwendig gepolijst en inwendig glas-gestraald.

Keuringsrapport volgens EN 10204/3.1.

Welded dairy tees acc. to DIN 11852. Surface outside satin and inside glass blasted.

Inspection certificate as per EN 10204/3.1.

Geschweisste T-Stücke für Molkereibetriebe, nach DIN 11852. Oberfläche aussen poliert und innen glas-gestrahlt.

Abnahmeprüfzeugnis nach EN 10204/3.1.

Tes soudés pour laiterie conformes à la norme DIN 11852. Surface extérieure polie et intérieure par soufflage de verre.
Certificat d'inspection selon la norme EN 10204/3.1.

Spec. 005

Gelaste zuivel T-stukken volgens DIN 11852. Oppervlak uitwendig en inwendig gebeitst.
Keuringsrapport volgens EN 10204/3.1.

Welded dairy tees acc. to DIN 11852. Surface outside and inside descaled.
Inspection certificate as per EN 10204/3.1.

Geschweisste Molkereigetriebe T-Stücke für Molkereibetriebe nach DIN 11852. Aussere und innere Oberfläche gebeitzt.
Abnahmeprüfzeugnis nach EN 10204/3.1.

Tes soudés pour laiterie conformes à la norme DIN 11852. Surface intérieure et extérieure décapés.
Certificat d'inspection selon la norme EN 10204/3.1.

**T-stukken
(gelijkzijdig)**

**Tees
(equal)**

**T-stücke
(egal)**

**Tes
(égaux)**

T-stukken (gelijkzijdig)

gelast en naadloos

Tees (equal)

welded and seamless

T-stücke (egal)

geschweisst und nahtlos

Tes (égaux)

soudés et sans soudure

Omschrijving op pagina 53-55
Description on page 53-55
Umschreibung auf Seite 53-55
Description à la page 53-55

- A = Afmeting vlg. ASME B 16.9, vervaardigd vlg. ASTM A403, afgeschuind vlg. ASME B 16.25
- A = Dimension to ASME B 16.9, produced to ASTM A403, ends bevelled to ASME B 16.25
- A = Abmessung nach ASME B 16.9, hergestellt nach ASTM A403, abgeschrägt nach ASME B 16.25
- A = Dimension selon la norme ASME B 16.9, fabriqués selon la norme ASTM A403, extrémités chanfreinées selon la norme ASME B 16.25
- B = Gepolijst - Polished - Poliert - Polis "■"
- B = Gebeitst - Pickled - Gebeitst - Décapés "□"
- L = type L met kleine opstaande rand; Type L with small branche; Type L mit kurzem Abzweig, Type L avec petit embranchement

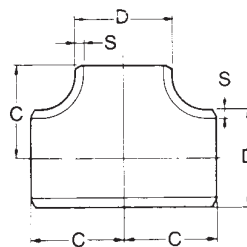

Norm-type A / ANSI
Norm-type S / DIN

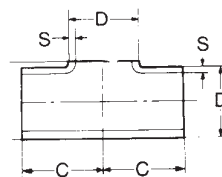

Norm-type L / DIN

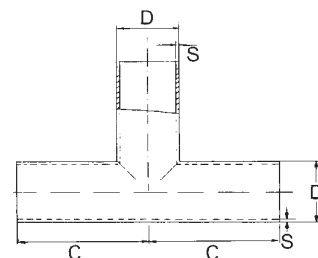

Norm-type B / DIN

mm Afmeting mm Size mm Abmessung Dimension en mm		inch Afmeting inch Size inch Abmessung Dimension en pouces		C	Norm type	+/- Kg. St./pc.	304L	304L	316L	316L
D	S						gelast welded geschw. soudés	naadloos seamless nahtlos. sans soudure	gelast welded geschw. soudés	naadloos seamless nahtlos sans soudure
21,30	1,60			25,5	L	0,15			X	
21,30	2,00			27,5	S	0,05			X	
21,34	2,11	1/2"	Sch 10 S	25,4	A	0,07	X	X	X	X
21,34	2,77	1/2"	Sch 40 S STD	25,4	A	0,08	X	X	X	X
21,34	3,73	1/2"	Sch 80 S XS	25,4	A	0,11		X		X
21,34	4,78	1/2"	Sch 160	25,4	A	0,15				X
25,40	1,50			75,0	B	0,19			X■□	
26,67	2,11	3/4"	Sch 10 S	28,6	A	0,09	X	X	X	X
26,67	2,87	3/4"	Sch 40 S STD	28,6	A	0,11	X	X	X	X
26,67	3,91	3/4"	Sch 80 S XS	28,6	A	0,16		X		X
26,67	5,56	3/4"	Sch 160	28,6	A	0,30				X
26,90	1,60			28,5	L	0,20			X	
28,00	1,50			50,0	B	0,11			X■□	
33,40	2,77	1"	Sch 10 S	38,1	A	0,20	X	X	X	X
33,40	3,38	1"	Sch 40 S STD	38,1	A	0,24	X	X	X	X
33,40	4,55	1"	Sch 80 S XS	38,1	A	0,32		X		X
33,40	6,35	1"	Sch 160	38,1	A	0,47				X
33,70	2,00			38,0	L + S	0,33			X	
38,10	1,50			90,0	B	0,33			X■□	
40,00	1,50			60,0	B	0,24			X■	
42,16	2,77	1.1/4"	Sch 10 S	47,6	A	0,33	X		X	X
42,16	3,68	1.1/4"	Sch 40 S STD	47,6	A	0,41	X	X	X	X
42,16	4,85	1.1/4"	Sch 80 S XS	47,6	A	0,54		X		X
42,40	2,00			47,5	L + S	0,35			X	
44,50	2,00			47,5	L	0,38			X	
48,26	2,77	1.1/2"	Sch 10 S	57,2	A	0,46	X	X	X	X
48,26	3,68	1.1/2"	Sch 40 S STD	57,2	A	0,60	X	X	X	X
48,26	5,08	1.1/2"	Sch 80 S XS	57,2	A	0,80		X		X
48,30	2,00			57,0	L + S	0,38			X	

**T-stukken
(gelijkzijdig)**

**Tees
(equal)**

**T-stücke
(egal)**

**Tes
(égaux)**

Omschrijving op pagina 53-55
Description on page 53-55
Umschreibung auf Seite 53-55
Description à la page 53-55

- A = Afmeting vlg. ASME B 16.9, vervaardigd vlg. ASTM A403, afgeschuind vlg. ASME B 16.25
- A = Dimension to ASME B 16.9, produced to ASTM A403, ends bevelled to ASME B 16.25
- A = Abmessung nach ASME B 16.9, hergestellt nach ASTM A403, abgeschrägt nach ASME B 16.25
- A = Dimension selon la norme ASME B 16.9, fabriqués selon la norme ASTM A403, extrémités chanfreinées selon la norme ASME B 16.25
- B = Gepolijst - Polished - Poliert - Polis "■"
- B = Gebeitst - Pickled - Gebeitst - Décapés "□"
- L = type L met kleine opstaande rand; Type L with small branche; Type L mit kurzem Abzweig, Type L avec petit embranchement

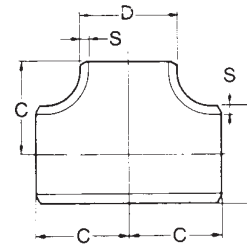

**Norm-type A / ANSI
Norm-type S / DIN**

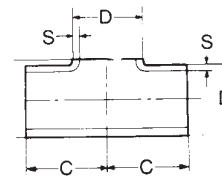

Norm-type L / DIN

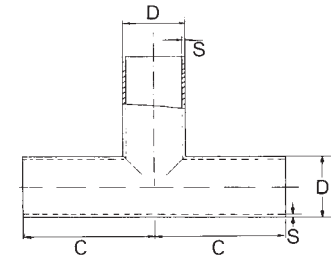

Norm-type B / DIN

mm Afmeting mm Size mm Abmessung Dimension en mm		inch Afmeting inch Size inch Abmessung Dimension en pouces		C	Norm type	+/- Kg. St./pc.	304L	304L	316L	316L
D	S						gelast welded geschw. soudés	naadloos seamless nahtlos. sans soudure	gelast welded geschw. soudés	naadloos seamless nahtlos sans soudure
50,80	1,50			100,0	B	0,49			X■□	
52,00	1,50			72,0	B	0,40			X■	
54,00	2,00			63,5	L	0,38			X	
60,30	2,00			63,5	L + S	0,48			X	
60,33	2,77	2"	Sch 10 S	63,5	A	0,63	X	X	X	X
60,33	3,91	2"	Sch 40 S STD	63,5	A	0,87	X	X	X	X
60,33	5,54	2"	Sch 80 S XS	63,5	A	1,20		X		X
60,33	8,74	2"	Sch 160	63,5	A	3,18				X
63,50	1,50			115,0	B	0,67			X■□	
69,00	2,00			76,0	L	0,38	X		X	
70,00	2,00			85,0	B	0,69			X■	
73,03	3,05	2.1/2"	Sch 10 S	76,2	A	1,01	X	X	X	X
73,03	5,16	2.1/2"	Sch 40 S STD	76,2	A	1,66	X		X	X
76,10	1,50			130,0	B	0,91			X□	
76,10	2,00			130,0	B	1,19			X■	
76,10	2,00			76,0	L + S	0,97			X	
76,10	3,00			76,0	L	1,45			X	
84,00	2,00			85,5	L	0,57	X		X	
88,90	2,00			85,5	L + B	0,57			X	
88,90	3,05	3"	Sch 10 S	85,7	A	1,37	X	X	X	X
88,90	5,49	3"	Sch 40 S STD	85,7	A	1,90	X	X	X	X
88,90	7,62	3"	Sch 80 S XS	85,7	A	3,25		X		X
101,60	2,00			150,0	B	1,90	X■		X■□	
104,00	2,00			105,0	L + B	1,40	X		X■	
114,30	2,00			105,0	L + S	1,50			X	
114,30	3,05	4"	Sch 10 S	104,8	A	2,15	X	X	X	X
114,30	6,02	4"	Sch 40 S STD	104,8	A	4,13	X	X	X	X
114,30	8,56	4"	Sch 80 S XS	104,8	A	5,74		X		X

**T-stukken
(gelijkzijdig)**

**Tees
(equal)**

**T-stücke
(egal)**

**Tes
(égaux)**

Omschrijving op pagina 53-55
Description on page 53-55
Umschreibung auf Seite 53-55
Description à la page 53-55

- A = Afmeting vlg. ASME B 16.9, vervaardigd vlg. ASTM A403, afgeschuind vlg. ASME B 16.25
- A = Dimension to ASME B 16.9, produced to ASTM A403, ends bevelled to ASME B 16.25
- A = Abmessung nach ASME B 16.9, hergestellt nach ASTM A403, abgeschragt nach ASME B 16.25
- A = Dimension selon la norme ASME B 16.9, fabriqués selon la norme ASTM A403, extrémités chanfreinées selon la norme ASME B 16.25
- B = Gepolijst - Polished - Poliert - Polis "■"
- B = Gebeitst - Pickled - Gebeitz - Décapés "□"
- L = type L met kleine opstaande rand; Type L with small branche; Type L mit kurzem Abzweig, Type L avec petit embranchement

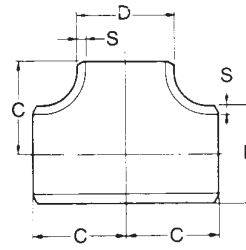

**Norm-type A / ANSI
Norm-type S / DIN**

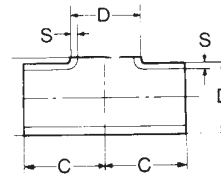

Norm-type L / DIN

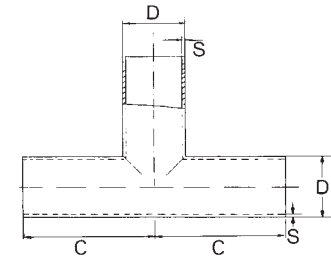

Norm-type B / DIN

mm Afmeting mm Size mm Abmessung Dimension en mm		inch Afmeting inch Size inch Abmessung Dimension en pouces		C	Norm type	+/- Kg. St./pc.	304L	304L	316L	316L
D	S						gelast welded geschw. soudés	naadloos seamless nahtlos. sans soudure	gelast welded geschw. soudés	naadloos seamless nahtlos sans soudure
129,00	2,00			124,0	L	1,39			X	
139,70	2,00			124,0	L	1,48			X	
139,70	3,00			124,0	L	3,55	X		X	
141,30	3,40	5"	Sch 10 S	123,8	A	3,48	X	X	X	
141,30	6,55	5"	Sch 40 S STD	123,8	A	6,55	X			X
154,00	2,00			143,0	L	2,00			X	
156,00	3,00			143,0	L	5,40			X	
168,28	3,40	6"	Sch 10 S	142,8	A	4,76	X	X	X	X
168,28	7,11	6"	Sch 40 S STD	142,8	A	9,73	X	X	X	X
168,28	10,97	6"	Sch 80 S XS	142,8	A	12,80		X		X
168,30	2,00			143,0	L	4,40			X	
168,30	3,00			143,0	L	5,40			X	
204,00	2,00			178,0	L	7,20			X	
219,08	3,76	8"	Sch 10 S	177,8	A	8,46	X	X	X	X
219,08	8,18	8"	Sch 40 S STD	177,8	A	18,00	X	X	X	X
219,10	3,00			178,0	L	7,21			X	
254,00	2,00			216,0	L	5,53			X	
256,00	3,00			216,0	L	8,50			X	
273,00	3,00			216,0	L	10,00	X		X	
273,05	4,19	10"	Sch 10 S	215,9	A	14,20	X		X	
273,05	9,27	10"	Sch 40 S STD	215,9	A	30,80	X	X	X	X
304,00	2,00			254,0	B	8,00			X	
323,85	4,57	12"	Sch 10 S	254,0	A	21,60	X		X	X
323,90	3,00			254,0	B	15,62	X		X	
355,60	4,78	14"	Sch 10 S	279,0	A	27,30	X		X	
406,40	3,00			305,0	B	15,00			X	
508,00	5,56	20"	Sch 10 S	381,0	A	70,00	X		X	

Verloop T-stukken

gelast en naadloos

Reducing Tees

welded and seamless

Reduzier T-stücke

geschweisst und nahtlos

Tes-réduits

soudés et sans soudure

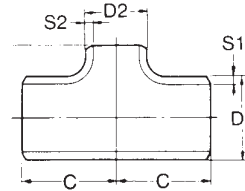

Verloop T-stukken

Reducing Tees

Reduzier T-stücke

Tes-réduits

Omschrijving op pagina 53-55

Description on page 53-55

Umschreibung auf Seite 53-55

Description à la page 53-55

Afmeting vlg. ASME B 16.9, vervaardigd vlg. ASTM A403, afgeschuind vlg. ASME B 16.25

Dimension to ASME B 16.9, produced to ASTM A403, ends bevelled to ASME B 16.25

Abmessung nach ASME B 16.9, hergestellt nach ASTM A403, abgeschrägt nach ASME B 16.25

Dimension selon la norme ASME B 16.9, fabriqués selon la norme ASTM A403, extrémités

chanfreinées selon la norme ASME B 16.25

Afmeting Size Abmessung Dimension			D1	D2	S1	S2	C	+/- Kg. St./pc.	304L gelast welded geschw. soudés	304L naadloos seamless nahtlos sans soudure	316L gelast welded geschw. soudés	316L naadloos seamless nahtlos sans soudure
3/4"	1/2"	Sch 10 S	26,67	21,34	2,11	2,11	28,58	0,06			X	X
3/4"	1/2"	Sch 40 S STD	26,67	21,34	2,87	2,77	28,58	0,12		X	X	X
3/4"	1/2"	Sch 80 S XS	26,67	21,34	3,91	3,73	28,58	0,15				X
1"	1/2"	Sch 10 S	33,40	21,34	2,77	2,11	38,10	0,19		X	X	X
1"	1/2"	Sch 40 S STD	33,40	21,34	3,38	2,77	38,10	0,22		X	X	X
1"	1/2"	Sch 80 S XS	33,40	21,34	4,55	3,73	38,10	0,28		X		X
1"	3/4"	Sch 10 S	33,40	26,67	2,77	2,11	38,10	0,19		X		X
1"	3/4"	Sch 40 S STD	33,40	26,67	3,38	2,87	38,10	0,23		X		X
1"	3/4"	Sch 80 S XS	33,40	26,67	4,55	3,91	38,10	0,29				X
1.1/4"	3/4"	Sch 40 S STD	42,16	26,67	3,56	2,87	47,60	0,37				X
1.1/4"	1"	Sch 10 S	42,16	33,40	2,77	2,77	47,60	0,31			X	
1.1/2"	1/2"	Sch 10 S	48,26	21,34	2,77	2,11	57,15	0,42			X	X
1.1/2"	1/2"	Sch 40 S STD	48,26	21,34	3,68	2,77	57,15	0,51		X		X
1.1/2"	3/4"	Sch 10 S	48,26	26,67	2,77	2,11	57,15	0,40				X
1.1/2"	3/4"	Sch 40 S STD	48,26	26,67	3,68	2,87	57,15	0,52		X	X	X
1.1/2"	3/4"	Sch 80 S XS	48,26	26,67	5,08	3,91	57,15	0,69				X
1.1/2"	1"	Sch 10 S	48,26	33,40	2,77	2,77	57,15	0,42	X	X	X	X
1.1/2"	1"	Sch 40 S STD	48,26	33,40	3,68	3,38	57,15	0,55		X		X
1.1/2"	1"	Sch 80 S XS	48,26	33,40	5,08	4,55	57,15	0,73				X
1.1/2"	1.1/4"	Sch 40 S STD	48,26	42,16	3,68	3,56	57,15	0,57				X
2"	1/2"	Sch 10 S	60,33	21,34	2,77	2,11	63,50	0,50			X	X
2"	3/4"	Sch 10 S	60,33	26,67	2,77	2,11	63,50	0,52				X
2"	3/4"	Sch 40 S STD	60,33	26,67	3,91	2,87	63,50	0,70		X		X
2"	3/4"	Sch 80 S XS	60,33	26,67	5,54	3,91	63,50	0,95				X
2"	1"	Sch 10 S	60,33	33,40	2,77	2,77	63,50	0,54	X	X	X	X
2"	1"	Sch 40 S STD	60,33	33,40	3,91	3,38	63,50	0,74		X		X
2"	1"	Sch 80 S XS	60,33	33,40	5,54	4,55	63,50	1,02		X		X
2"	1.1/4"	Sch 10 S	60,33	42,16	2,77	2,77	63,50	0,57	X	X	X	X
2"	1.1/4"	Sch 40 S	60,33	42,16	3,91	3,56	63,50	0,80		X	X	
2"	1.1/2"	Sch 10 S	60,33	48,26	2,77	2,77	63,50	0,59	X	X	X	X
2"	1.1/2"	Sch 40 S STD	60,33	48,26	3,91	3,68	63,50	0,83		X	X	X
2.1/2"	1.1/2"	Sch 10 S	73,03	48,26	3,05	2,77	76,20	0,90	X	X	X	
2.1/2"	1.1/2"	Sch 40 S	73,03	48,26	5,16	3,68	76,20	1,49		X	X	
2.1/2"	2"	Sch 10 S	73,03	60,33	3,05	2,77	76,20	0,94		X		X
3"	1"	Sch 10 S	88,90	33,40	3,05	2,77	85,73	1,10	X			X
3"	1"	Sch 40 S STD	88,90	33,40	5,49	3,38	85,73	1,90		X		X
3"	1.1/2"	Sch 10 S	88,90	48,26	3,05	2,77	85,73	1,19		X	X	X
3"	1.1/2"	Sch 40 S STD	88,90	48,26	5,49	3,68	85,73	2,05		X		X
3"	1.1/2"	Sch 80 S	89,00	48,60	7,62	5,08	86,0	4,29				X

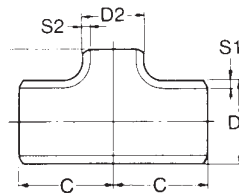

Omschrijving op pagina 53-55
Description on page 53-55
Umschreibung auf Seite 53-55
Description à la page 53-55

Afmeting vlg. ASME B 16.9, vervaardigd vlg. ASTM A403, afgeschuind vlg. ASME B 16.25
Dimension to ASME B 16.9, produced to ASTM A403, ends bevelled to ASME B 16.25
Abmessung nach ASME B 16.9, hergestellt nach ASTM A403, abgescrängt nach ASME B 16.25
Dimension selon la norme ASME B 16.9, fabriqués selon la norme ASTM A403, extrémités chanfreinées selon la norme ASME B 16.25

Afmeting Size Abmessung Dimension			D1	D2	S1	S2	C	+/- Kg. St./pc.	304L gelast welded geschw. soudés	304L naadloos seamless nahtlos sans soudure	316L gelast welded geschw. soudés	316L naadloos seamless nahtlos sans soudure
3"	2"	Sch 10 S	88,90	60,33	3,05	2,77	85,73	1,23	X	X	X	X
3"	2"	Sch 40 S STD	88,90	60,33	5,49	3,91	85,73	2,16		X	X	X
3"	2"	Sch 80 S XS	88,90	60,33	7,62	5,54	85,73	2,85				X
4"	1.1/2"	Sch 10 S	114,30	48,26	3,05	2,77	104,78	1,75			X	X
4"	1.1/2"	Sch 40 S STD	114,30	48,26	6,02	3,68	104,78	3,41				X
4"	2"	Sch 10 S	114,30	60,33	3,05	2,77	104,78	1,88	X	X	X	X
4"	2"	Sch 40 S STD	114,30	60,33	6,02	3,91	104,78	3,52		X	X	X
4"	2.1/2"	Sch 10 S	114,30	73,03	3,05	3,05	104,78	1,95				X
4"	3"	Sch 10 S	114,30	88,90	3,05	3,05	104,78	2,02	X	X	X	X
4"	3"	Sch 40 S STD	114,30	88,90	6,02	5,49	104,78	3,83		X	X	X
6"	3"	Sch 10 S	168,28	88,90	3,40	3,05	142,88	4,21	X	X	X	X
6"	3"	Sch 40 S STD	168,28	88,90	7,11	5,49	142,88	8,52	X	X		X
6"	4"	Sch 10 S	168,28	114,30	3,40	3,05	142,88	4,34	X	X	X	X
6"	4"	Sch 40 S STD	168,28	114,30	7,11	6,02	142,88	8,81	X	X		X
6"	5"	Sch 10 S	168,28	141,30	3,40	3,05	142,88	4,56		X		
8"	4"	Sch 10 S	219,08	114,30	3,76	3,05	178,00	7,48	X	X	X	X
8"	6"	Sch 10 S	219,08	168,28	3,76	3,40	178,00	7,91	X	X	X	X
8"	6"	Sch 40 S STD	219,08	168,28	8,18	7,11	178,00	16,80	X	X	X	X
10"	6"	Sch 10 S	273,05	168,28	4,19	3,40	216,00	12,80	X		X	X
10"	6"	Sch 40 S	273,05	168,28	9,27	7,11	216,00	27,60	X		X	
10"	8"	Sch 10 S	273,05	219,08	4,19	3,76	216,00	13,30	X		X	
12"	8"	Sch 10 S	323,85	219,08	4,57	3,76	254,00	19,60			X	
12"	10"	Sch 40 S	323,85	273,00	9,53	9,27	254,00	63,00			X	

Stub-ends

Stub-ends

Stub-ends

Stub-ends

Stub-ends

Stub-ends

Stub-ends

Stub-ends

Spec. 001

Naadloze stub-ends volgens ASTM A403 met toleranties volgens MSS SP-43 type A/ASME B16.9.

Keuringsrapport volgens EN 10204/3.1 voor zowel het kraageind als het basismateriaal.

Interkristallijne corrosietest volgens ASTM A262 pr. E en PMI-test d.m.v. spectrograph.

Hardheid HRC 22 max. volgens NACE MR01-75 laatste uitgave.

Ruwheid pakkingvlak 125 - 250 rms. Stub-ends tweevoudig gecertificeerd.

Seamless stub-ends acc. to ASTM A403 with tolerances acc. to MSS SP-43 type A/ASME B16.9.

Inspection certificate as per EN 10204/3.1 from the stub-ends and the base material.

Intergranular corrosion test acc. to ASTM A262 pr. E and PMI-test by spectrograph.

Hardness HRC 22 max. acc. to NACE MR01-75 latest edition.

Roughness of the gasket surface 125 - 250 rms. Stub-ends dual certified.

Nahtlose Stub-ends nach ASTM A403 mit Toleranzen nach MSS SP-43 Type A/ASME B16.9.

Abnahmeprüfzeugnis nach EN 10204/3.1 für Stub-ends und Grundwerkstoff.

Interkristalline Korrosion nach ASTM A262 pr. E und Verwechslungsprüfung durch Spectrograph.

Härte HRC max. 22 nach NACE MR01-75 letzte Ausgabe.

Rauhigkeit der Dichtfläche 125 - 250 rms. Stub-ends zweifach zertifiziert.

Stub-ends sans soudure conformes à la norme ASTM A403 avec tolérances conformes à la norme MSS SP-43 – type A/ASME B16.9.

Certificat d'inspection selon la norme EN 10204/3.1, pour le stub-end et la matière de base.

Test de corrosion intergranulaire conformes à la norme ASTM A262 E. Test PMI par spectrographie.

Dureté HRC 22 max. conformément à la norme NACE MR01-75 (dernière édition).

Rugosité de la surface du joint : 125 – 250 mr. Double certification.

Spec. 002

Gelaste stub-ends volgens ASTM A403 met toleranties volgens MSS SP-43. Keuringsrapport volgens EN 10204/3.1 voor zowel het kraageind als het basismateriaal. Stub-ends tweevoudig gecertificeerd.

Welded stub-ends acc. to ASTM A403 with tolerances acc. to MSS SP 43.

Inspection certificate as per EN 10204/3.1 from the stub-ends and the base material. Stub-ends dual certified.

Geschweisste Stub-ends nach ASTM A403 mit Toleranzen nach MSS SP-43 . Abnahmeprüfzeugnis nach EN 10204/3.1 für Stub-ends und Grundwerkstoff. Stub-ends zweifach zertifiziert.

Stub-ends soudées conformes à la norme ASTM A403 avec tolérances conformes à la norme MSS SP 43.

Certificat d'inspection selon la norme EN 10204/3.1, pour le stub-end et la matière de base.

Double certification.

Stub-ends

Omschrijving op pagina 61
Description on page 61
Umschreibung auf Seite 61
Description à la page 61

Stub-ends

Stub-ends

Stub-ends

Afmeting vlg. MSS SP 43 type A / ASME B 16.9, vervaardigd vlg. ASTM A403, afgeschuind vlg. ASME B 16.25
Dimension to MSS SP 43 type A / ASME B 16.9, produced to ASTM A403, ends bevelled to ASME B 16.25
Abmessung nach MSS SP 43 type A / ASME B 16.9, hergestellt nach ASTM A403, abgeschrägt nach ASME B 16.25
Dimension selon la norme MSS SP 43 type A / ASME B 16.9, fabriqués selon la norme ASTM A403, extrémités chanfreinées selon la norme ASME B 16.25

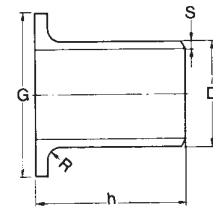

Inch. diam.		D mm	S mm	h mm	G mm	R mm	+/- Kg. St./pc.	304L gelast welded geschw. soudés	304L naadloos seamless nahtlos sans soudure	316L gelast welded geschw. soudés	316L naadloos seamless nahtlos sans soudure
1/2"	Sch 10 S	21,34	2,11	50,8	34,9	3,18	0,06		X		X
1/2"	Sch 40 S STD	21,34	2,77	50,8	34,9	3,18	0,08		X		X
1/2"	Sch 80 S XS	21,34	3,73	50,8	34,9	3,18	0,13				X
3/4"	Sch 10 S	26,67	2,11	50,8	42,9	3,18	0,08		X		X
3/4"	Sch 40 S STD	26,67	2,87	50,8	42,9	3,18	0,10		X	X	X
1"	Sch 10 S	33,40	2,77	50,8	50,8	3,18	0,13		X		X
1"	Sch 40 S STD	33,40	3,38	50,8	50,8	3,18	0,16		X		X
1"	Sch 80 S XS	33,40	4,55	50,8	50,8	3,18	0,19		X		
1.1/4"	Sch 10 S	42,16	2,77	50,8	63,5	4,76	0,18		X		X
1.1/4"	Sch 40 S STD	42,16	3,56	50,8	63,5	4,76	0,23		X		X
1.1/2"	Sch 10 S	48,26	2,77	50,8	73,0	6,35	0,21		X		X
1.1/2"	Sch 40 S STD	48,26	3,68	50,8	73,0	6,35	0,28		X		X
2"	Sch 10 S	60,33	2,77	63,5	92,1	7,94	0,34	X	X	X	X
2"	Sch 40 S STD	60,33	3,91	63,5	92,1	7,94	0,47		X		X
2.1/2"	Sch 10 S	73,03	3,05	63,5	104,8	7,94	0,45	X	X	X	X
3"	Sch 10 S	88,90	3,05	63,5	127,0	9,53	0,57	X	X	X	X
3"	Sch 40 S STD	88,90	5,49	63,5	127,0	9,53	1,01	X	X	X	X
4"	Sch 10 S	114,30	3,05	76,2	157,2	11,11	0,87	X	X	X	X
4"	Sch 40 S STD	114,30	6,02	76,2	157,2	11,11	1,68	X	X	X	X
5"	Sch 10 S	141,30	3,40	76,2	185,7	11,11	1,21	X	X	X	X
5"	Sch 40 S STD	141,30	6,55	76,2	185,7	11,11	2,28		X	X	X
6"	Sch 10 S	168,28	3,40	88,9	215,9	12,70	1,64	X	X	X	X
6"	Sch 40 S STD	168,28	7,11	88,9	215,9	12,70	3,37		X	X	X
8"	Sch 10 S	219,08	3,76	101,4	269,9	12,70	2,65	X	X	X	X
8"	Sch 40 S STD	219,08	8,18	101,4	269,9	12,70	5,67	X	X	X	X
10"	Sch 10 S	273,05	4,19	127,0	323,9	12,70	4,38	X	X	X	X
12"	Sch 10 S	323,85	4,57	152,4	381,0	12,70	6,74	X	X	X	X
12"	Sch 40 S STD	323,85	9,53	152,4	381,0	12,70	13,80	X		X	
14"	Sch 10 S	355,60	4,78	152,4	412,8	12,70	7,73	X	X	X	X
16"	Sch 10 S	406,40	4,78	152,4	469,9	12,70	9,00	X		X	X
18"	Sch 10 S	457,20	4,78	152,4	533,4	12,70	10,50	X		X	
20"	Sch 10 S	508,00	5,56	152,4	584,2	12,70	13,50			X	X

Caps Caps Kappen Caps

Caps

Caps

Kappen

Caps

Spec. 001

Naadloze caps volgens ASTM A403 en ASME B16.9. Keuringsrapport volgens EN 10204/3.1 van zowel de cap als het basismateriaal.
Alle caps aanvullend getest op interkristallijne corrosie volgens ASTM A262 pr.E en PMI d.m.v. spectrograph.
Hardheid HRC 22 max. volgens NACE MR01-75 laatste uitgave. Caps tweevoudig gecertificeerd.

Seamless caps acc. to ASTM A403 and ASME B16.9. Inspection certificate as per EN 10204/3.1 for the cap and the base material.
All caps additionally tested on intergranular corrosion acc. to ASTM A262 pr. E and PMI-tested by spectrograph.
Hardness HRC 22 max. acc. to NACE MR01-75 latest edition. Caps dual certified.

Nahtlose Kappen nach ASTM A403 und ASME B16.9. Abnahmeprüfzeugnis nach EN 10204/3.1 für Kappe und Grundwerkstoff.
Alle Kappen zusätzlich geprüft auf Interkristalline Korrosion nach ASTM A262 pr.E und mit Verwechslungsprüfung durch Spectrograph.
Härte HRC max. 22 nach NACE MR01-75 letzte Ausgabe. Kappen zweifach zertifiziert.

Cap sans soudure conformes aux normes ASTM A403 et ASME B16.9. Certificat d'inspection selon la norme EN 10204/3.1, pour le cap et la matière de base. Tous les caps sont également testés pour leur corrosion intergranulaire, conformément à la norme ASTM A262 pr. E. Test PMI par spectrographe.
Dureté HCR 22 max., conformément à la norme NACE MR01-75 (dernière édition). Double certification.

Een groot deel van ons assortiment caps is ook leverbaar van door STOOMWEZEN goedgekeurde leveranciers

A major part of our stockprogramme caps is also available from STOOMWEZEN approved suppliers

Einen grossen Teil aus unserem nahtlosen Sortiment Kappen können wir auch nach STOOMWEZEN-anerkannten Lieferanten liefern.

La plupart des obturateurs de notre gamme sont également disponibles et fabriqués par des fournisseurs agréés « STOOMWEZEN ».

Spec. 002

Lasbodems volgens DIN 28011 R=D en r=0,1D. Interkristallijne corrosietest volgens DIN 50914 of NF A 05-159.
Keuringsrapport volgens EN 10204/3.1.

Caps acc. to DIN 28011 R=D and r=0,1D. Intergranular corrosion test acc. to DIN 50914 or NF A 05-159.
Inspection certificate as per EN 10204/3.1.

Klöpperböden nach DIN 28011 R=D und r=0,1D. Interkristalline Korrosion Prüfung nach DIN 50914 oder NF A 05-159.
Abnahmeprüfzeugnis nach EN 10204/3.1.

Fonds conformes à la norme DIN 28011. R=D et r=0,1D. Test de résistance à la corrosion intergranulaire conformément à la norme DIN 50914 ou NF A 05-159. Certificat d'inspection selon la norme EN 10204/3.1.

Caps

Omschrijving op pagina 63
Description on page 63
Umschreibung auf Seite 63
Description à la page 63

Caps

Kappen

Caps

Afmetingen volgens ASME B 16.9, vervaardigd volgens ASTM A403, afgeschuind volgens ASME B 16.25
Dimensions to ASME B 16.9, produced to ASTM A403, ends bevelled to ASME B 16.25
Abmessungen nach ASME B 16.9, hergestellt nach ASTM A403, abgeschrägt nach ASME B 16.25
Dimensions selon la norme ASME B 16.9, fabriqués selon la norme ASTM A403, extrémités chanfreinées selon la norme ASME B 16.25

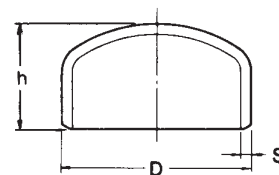

Inch Afmeting Inch Size Inch Abmessung Dimensions en pouces		D mm	S mm	h mm	+/- Kg. St./pc.	304L	316L
1/2"	Sch 10 S	21,34	2,11	25,4	0,03		X
1/2"	Sch 40 S STD	21,34	2,77	25,4	0,04	X	X
3/4"	Sch 10 S	26,67	2,11	25,4	0,04	X	X
3/4"	Sch 40 S STD	26,67	2,87	25,4	0,05	X	X
1"	Sch 10 S	33,40	2,77	38,1	0,09	X	X
1"	Sch 40 S STD	33,40	3,38	38,1	0,11	X	X
1"	Sch 80 S XS	33,40	4,55	38,1	0,14	X	X
1.1/4"	Sch 10 S	42,16	2,77	38,1	0,11	X	X
1.1/4"	Sch 40 S STD	42,16	3,56	38,1	0,14		X
1.1/4"	Sch 80 S XS	42,16	5,08	38,1	0,19		X
1.1/2"	Sch 10 S	48,26	2,77	38,1	0,13	X	X
1.1/2"	Sch 40 S STD	48,26	3,68	38,1	0,17	X	X
1.1/2"	Sch 80 S XS	48,26	5,08	38,1	0,23	X	X
2"	Sch 10 S	60,33	2,77	38,1	0,17	X	X
2"	Sch 40 S STD	60,33	3,91	38,1	0,23	X	X
2"	Sch 80 S XS	60,33	5,54	38,1	0,33		X
2.1/2"	Sch 10 S	73,03	3,05	38,1	0,23		X
2.1/2"	Sch 40 S STD	73,03	5,16	38,1	0,39		X
3"	Sch 10 S	88,90	3,05	50,8	0,37	X	X
3"	Sch 40 S STD	88,90	5,49	50,8	0,66	X	X
3"	Sch 80 S XS	88,90	7,62	50,8	0,92	X	X
4"	Sch 10 S	114,30	3,05	63,5	0,59	X	X
4"	Sch 40 S STD	114,30	6,02	63,5	1,17	X	X
4"	Sch 80 S XS	114,30	8,56	63,5	1,67		X
5"	Sch 10 S	141,30	3,40	76,2	0,99	X	X
5"	Sch 40 S STD	141,30	6,55	76,2	1,91	X	X
6"	Sch 10 S	168,28	3,40	88,9	1,39	X	X
6"	Sch 40 S STD	168,28	7,11	88,9	2,90	X	X
6"	Sch 80 S XS	168,28	10,97	88,9	4,74	X	X
8"	Sch 10 S	219,08	3,76	101,6	2,38	X	X
8"	Sch 40 S STD	219,08	8,18	101,6	5,19	X	X
10"	Sch 10 S	273,05	4,19	127,0	4,14	X	X
10"	Sch 40 S STD	273,05	9,27	127,0	9,15	X	X
12"	Sch 10 S	323,85	4,75	152,4	6,39	X	X
12"	Sch 40 S STD	323,85	9,53	152,4	13,30	X	X
14"	Sch 10 S	355,60	4,78	165,1	7,98	X	X
16"	Sch 10 S	406,40	4,78	177,8	10,00	X	X
20"	Sch 10 S	508,00	5,56	228,6	18,50	X	X
24"	Sch 10 / Sch 10 S	609,60	6,35	266,7	30,10	X	X

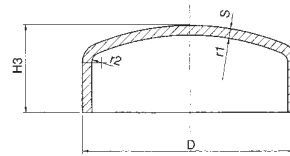

Lasbodems

Caps

Klöpperböden

Fonds

D mm	S mm	H3 mm	r1 mm	r2 mm	+/- Kg. St./pc.	1.4404
54,0	2,0	17	54,00	5,40	0,07	X
60,3	2,0	19	60,30	6,03	0,07	X
69,0	2,0	20	69,00	6,90	0,12	X
76,1	2,0	26	76,10	7,61	0,12	X
76,1	3,0	27	76,10	7,61	0,18	X
84,0	2,0	27	84,00	8,40	0,17	X
88,9	2,0	29	88,90	8,89	0,16	X
104,0	2,0	30	104,00	10,40	0,26	X
114,3	2,0	28	114,30	11,43	0,26	X
114,3	3,0	31	114,30	11,43	0,39	X
129,0	2,0	34	129,00	12,90	0,38	X
139,7	2,0	35	139,70	13,97	0,38	X
139,7	3,0	36	139,70	13,97	0,57	X
154,0	2,0	40	154,00	15,40	0,55	X
168,3	2,0	49	168,30	16,83	0,55	X
168,3	3,0	49	168,30	16,83	0,82	X
204,0	2,0	47	204,00	20,40	1,00	X
206,0	3,0	49	206,00	20,60	1,50	X
219,1	2,0	54	219,10	21,91	0,96	X
219,1	3,0	54	219,10	21,91	1,44	X
254,0	2,0	55	254,00	25,40	1,43	X
256,0	3,0	66	256,00	25,60	2,15	X
273,0	2,0	65	273,00	27,30	2,00	X
273,0	3,0	65	273,00	27,30	2,52	X
304,0	2,0	66	304,00	30,40	1,97	X
306,0	3,0	75	306,00	30,60	2,96	X
323,9	2,0	72	323,90	32,40	2,48	X
323,9	3,0	83	323,90	32,40	2,90	X
356,0	3,0	79	356,00	35,60	3,17	X
406,0	3,0	88	406,00	40,60	4,16	X
506,0	3,0	108	506,00	50,60	6,56	X

Kapbeugels

Pipe clips

Kappschelle

Clips

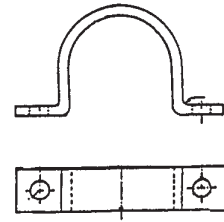

Buis diam. Tubes diam. Rohr Diam. Diam. Tubes	1.4301
21,3 mm	X
25,0 mm	X
26,9 mm	X
30,0 mm	X
33,7 mm	X
38,0 mm	X
42,4 mm	X
44,5 mm	X
48,3 mm	X
57,0 mm	X
60,3 mm	X
76,1 mm	X
88,9 mm	X
104,0 mm	X
114,3 mm	X
139,7 mm	X

Pijpbeugels

Double clips

Doppelschellen

Colliers pour tubes

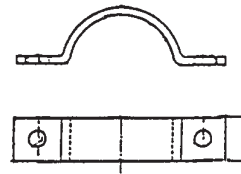

Buis diam. Tubes diam. Rohr Diam. Diam. Tubes	1.4301
21,3 mm	X
26,9 mm	X
33,7 mm	X
38,0 mm	X
42,4 mm	X
44,5 mm	X
48,3 mm	X
54,0 mm	X
57,0 mm	X
60,3 mm	X
76,1 mm	X
84,0 mm	X
88,9 mm	X
104,0 mm	X
108,0 mm	X
114,3 mm	X
129,0 mm	X
139,7 mm	X
154,0 mm	X
168,3 mm	X
204,0 mm	X
219,1 mm	X
254,0 mm	X
273,0 mm	X
323,9 mm	X

Boordringen

Pressed collars

Bördel

Collets emboutis

Boordringen

Aansluitmaten volgens EN 1092-1

Pressed collars

Connections according EN 1092-1

Bördel

Anschlüsse nach EN 1092-1

Collets emboutis

Raccords selon la norme EN 1092-1

Spec. 001

Boordringen, aansluitmaten volgens EN 1092-1.

Interkristallijne corrosietest volgens EN ISO 3652-2, practice A.

Keuringsrapport volgens EN 10204/3.1.

Pressed collars, connections acc. to EN 1092-1.

Intergranular corrosion test acc. to EN ISO 3652-2, practice A.

Inspection certificate as per EN 10204/3.1.

Bördel, Anschlüsse nach EN 1092-1.

Interkristalline Korrosion nach EN ISO 3652-2, practice A.

Abnahmeprüfzeugnis nach EN 10204/3.1.

Collets emboutis, raccords conformes à la norme EN 1092-1.

Test de corrosion intergranulaire conforme à la norme EN ISO 3652-2, practice A.

Certificat d'inspection selon la norme EN 10204/3.1.

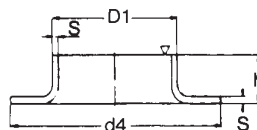

Boordringen

Pressed collars

Bördel

Collets emboutis

NW	mm D1	mm S	d4	min. h	+/- Kg. St./pc.	304L	316L
15	18,0	2	42	6	0,01	X	
	20,0	2	45	7	0,02	X	X
	21,3	2	45/47	6/7	0,01/0,02		X
	21,3	2.60	45	7	0,02	X	X
20	25,0	2	58	8	0,04	X	X
	26,9	2	58	7/9	0,04		X
	26,9	2,60	58	9	0,06	X	X
	26,9	3	58	8	0,06		X
25	28,0	2	68	9	0,05	X	X
	28,0	3	68	8	0,08		X
	30,0	2	68	10	0,08		X
	32,0	2	68	10	0,08	X	X
	33,7	2	68	9/10,5	0,05/0,11		X
	33,7	2,77	68	10,5	0,11		X
	33,7	2,90	68	10	0,08		X
	33,7	3,20	68	10,5	0,11	X	X
32	38,0	2	78	10	0,07		X
	42,4	2	78	10/14	0,07/0,14	X	X
	42,4	2,90	78	10	0,09		X
	42,4	3,20	78	14	0,14	X	X
40	44,5	2	88	12	0,09	X	X
	48,3	2	88	10/14	0,08/0,22	X	X
	48,3	2,77	88	15	0,22		X
	48,3	2,90	88	10	0,11		X
	48,3	3,20	88	14	0,22	X	X
50	51,0	2	102	15	0,12	X	X
	54,0	2	102	12	0,11	X	X
	57,0	3	102	15	0,17		X
	60,3	2	102	12/16	0,11/0,20	X	X
	60,3	2,77	102	15	0,20		X
	60,3	2,90	102	13	0,14	X	X
	60,3	3,60	102	16	0,25	X	X
60	64,0	2	115	13	0,13		X
65	69,0	2	122	12	0,28		X
	70,0	2	122	15	0,16		X
	70,0	3	122	20	0,24		X
	73,0	3,05	122	19	0,24		X
	76,1	2	122	12/19	0,15/0,30	X	X
	76,1	2,90	122	13	0,2	X	X
	76,1	3,60	122	19	0,37	X	
	80	84,0	2	133	13	0,19	X
86,0		3	133	20	0,28	X	X
88,9		2	133	13/23	0,19/0,40	X	X
88,9		3	133	14	0,25	X	X
88,9		3,05	133	23	0,40		X
88,9		4	133	23	0,49		X
100	102,0	2	158	15	0,24		X
	104,0	2	158	14	0,21	X	X
	106,0	3	158	20	0,31		X

Boordringen

Pressed collars

Bördel

Collets emboutis

Omschrijving op pagina 68
Description on page 68
Umschreibung auf Seite 68
Description à la page 68

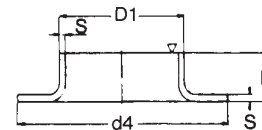

NW	mm D1	mm S	d4	min. h	+/- Kg. St./pc.	304L	316L
	108,0	2	158	20	0,25		X
	108,0	4	158	27	0,54		X
	114,3	2	158	13/26	0,21/0,65	X	X
	114,3	2,90	158	14	0,29	X	X
	114,3	3,05	158	22	0,36		X
	114,3	4	158	25	0,50		X
125	129,0	2	184	14	0,34	X	X
	133,0	4	184	20	0,72		X
	139,7	2	184	14/26	0,26/0,75	X	X
	139,7	2,90	184	15	0,43	X	X
	139,7	4	184	30	0,68		X
150	154,0	2	212	18	0,38	X	X
	156,0	3	212	25	0,60	X	X
	158,0	4	212	25	0,82	X	X
	168,3	2	212	18/29	0,34/0,90	X	X
	168,3	2,90	212	19	0,5	X	X
	168,3	3,40	212	25	0,55		X
	168,3	4	212	19	0,72		X
200	204,0	2	268	23	0,56	X	X
	206,0	3	268	25	0,83	X	X
	219,1	2	268	22/32	0,53/1,20	X	X
	219,1	2,90	268	23	0,76	X	X
	219,1	3	268	23	0,74	X	X
	219,1	3,76	268	25	0,74		X
	219,1	4	268	24	1,00	X	X
250	254,0	2	320	23	0,70	X	X
	256,0	3	320	25	1,04	X	X
	273,0	2	320	22/32	0,55/1,60		X
	273,0	2,90	320	23	0,82	X	X
	273,0	4	320	24/32	1,50/1,60	X	X
300	304,0	2	370	24	0,84	X	X
	306,0	3	370	24	1,28	X	X
	308,0	4	370	25	1,70	X	X
	323,9	2	370	24/36	0,65/2,00	X	X
	323,9	2,90	370	24	1,06	X	X
	323,9	4	370	25/36	1,40/2,00		X
	323,9	4,57	370	36	1,47		X
	323,9	5	370	36	1,47	X	X
350	355,6	2,90	430	25	1,55	X	X
	355,6	5	430	40	1,61	X	X
400	406,4	2,90	482	24	1,74	X	X
	408,0	4	482	24	2,64	X	
450	456,0	3	533	32	2,16		X
500	506,0	3	585	45	7,70	X	X
	508,0	3	585	45	7,70	X	X
	508,0	4	585	40/45	3,85/7,70	X	X
600	609,6	2,90	685	45	3,5	X	X

Aluminium en stalen overschuifflenzen
Aluminium and carbon steel slip-on flanges
Aluminium und stahlen Überschieb-Flansche
Brides tournantes en aluminium et en acier

Aluminium en
 stalen
 overschuifflenzen

Aluminium and
 carbon steel
 slip-on flanges

Aluminium und
 stahlen
 Überschieb-Flansche

Brides tournantes
 en aluminium et
 en acier

Spec. 001

Overschuifflenzen, aansluitmaten volgens EN 1092-1 type 02.

Slip-on flanges, connections acc. to EN 1092-1 type 02.

Überschieb-Flansche, Anschlüsse nach EN 1092-1 type 02.

Brides tournantes, raccords conformes à la norme EN 1092-1 type 02.

DN \ PN	2,5	6	10	16	25	40	63	100
10	Maten als PN 6							
15								
20								
25								
32								
40								
50								
65								
80								
100								
125								
150								
200								
250								
300								
350								
400								
450								
500								
600								
700								
800								

**Aluminium
overschuifflenzen**

**Aluminium
slip-on flanges**

**Aluminium
Flansche**

**Brides tournantes
en aluminium**

Aluminium overschuifflenzen

EN 1092-1 type 02

Aluminium slip-on flanges

EN 1092-1 type 02

Aluminium Flansche

EN 1092-1 type 02

Brides tournantes en aluminium

EN 1092-1 type 02

Omschrijving op pagina 71
Description on page 71
Umschreibung auf Seite 71
Description à la page 71

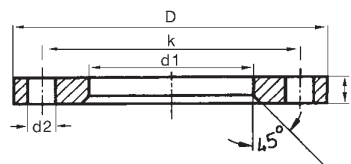

ND	BD buis						bouten bolting Schrauben boulons		± Kg	blank blank blank blanches	gecoat coated beschichtet peintes
NB	OD tube		Type A	Type C			nr	d2	St/pc		
NW	AD Rohr	D	d1	d1	b	k					
DN	DE tube										
10	17,2	90	-	19	12	60	4	14	0,18	X	X
15	21,3	95	-	24	16	65	4	15	0,19	X	X
20	26,9	105	-	30	16	75	4	15	0,25	X	X
25	33,7	115	-	36	16	85	4	15	0,27	X	X
32	42,4	140	-	46	16	100	4	18	0,56	X	X
40	48,3	150	-	54	18	110	4	18	0,62	X	X
50	54,0	165	60	-	18	125	4	18	0,75	X	X
	60,3	165	-	65	18	125	4	18	0,75	X	X
65	70,0	185	-	81	18	145	4	18	0,90	X	X
80	84,0	200	90	-	20	160	8	18	1,10	X	X
	88,9	200	-	94	20	160	8	18	1,10	X	X
100	104,0	220	111	-	20	180	8	18	1,23	X	X
	114,3	220	-	119	20	180	8	18	1,23	X	X
125	129,0	250	140	-	22	210	8	18	1,53	X	X
	139,7	250	-	145	22	210	8	18	1,53	X	X
150	154,0	285	165	-	22	240	8	22	1,88	X	X
	168,3	285	-	173	22	240	8	22	1,88	X	X
200	204,0	340	218	-	24	295	8	22	2,70	X	X
	219,1	340	-	225	24	295	8	22	2,70	X	X
250	254,0	395	270	-	26	350	12	22	3,65	X	X
	273,0	395	-	279	26	350	12	22	3,65	X	X
300	304,0	445	318	-	26	400	12	22	4,27	X	X
	323,9	445	-	329	26	400	12	22	4,27	X	X
350	355,6	505	-	370	26	460	16	22	5,20	X	X
400	406,4	565	-	420	32	515	16	25	7,17	X	X
450	457,0	615	-	465	32	565	20	25	9,50	X	
500	508,0	670	517	525	34	620	20	25	9,65	X	X
600	609,6	780	618	628	36	725	20	30	13,00	X	X

Elektrolytisch verzinkte stalen overschuifflenzen

EN 1092-1 type 02

Electrolytic galvanized carbon steel lapped flanges

EN 1092-1 type 02

Elektrolytisch galvanisierte lose Stahlflansche

EN 1092-1 type 02

Brides tournantes en acier galvanisé électrolytique

EN 1092-1 type 02

Omschrijving op pagina 71

Description on page 71

Umschreibung auf Seite 71

Description à la page 71

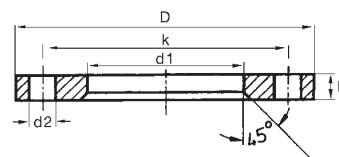

ND	BD buis					bouten bolting Schrauben boulons		± Kg	
NB	OD tube					nr	d2	St/pc	St 37
NW	AD Rohr	D	d1	b	k				
DN	DE Tube								
15	21,3	95	24	14	65	4	14	0,69	X
20	26,9	105	30	14	75	4	14	0,81	X
25	33,7	115	36	16	85	4	14	1,11	X
32	42,4	140	46	16	100	4	18	1,64	X
40	48,3	150	54	16	110	4	18	1,86	X
50	60,3	165	65	16	125	4	18	2,20	X
65	76,1	185	81	16	145	4	18	2,62	X
80	88,9	200	94	18	160	8	18	3,32	X
100	114,3	220	119	18	180	8	18	3,67	X
125	139,7	250	145	18	210	8	18	4,54	X
150	168,3	285	173	18	240	8	22	5,60	X
200	219,1	340	225	20	295	8	22	7,46	X
250	273,0	395	279	22	350	12	22	10,30	X
300	323,9	445	329	26	400	12	22	14,00	X
350	355,6	505	362	26	460	16	22	18,50	X
400	406,4	565	413	32	515	16	26	25,00	X
500	508,0	670	517	38	620	20	26	37,00	X

Geperste overschuifflenzen - geel verchroomd

EN 1092-1 type 02

Pressed loose flanges - yellow passivated

EN 1092-1 type 02

Gepresste Losflansche - gelb passiviert

EN 1092-1 type 02

Brides tournantes embouties - bichromaté jaun

EN 1092-1 type 02

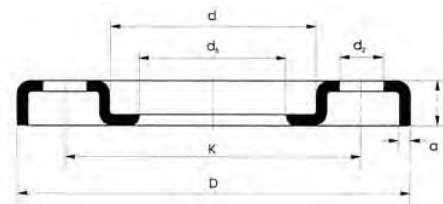

Omschrijving op pagina 71 / Description on page 71 / Umschreibung auf Seite 71 / Description à la page 71

ND	BD buis	Flens afmeting Flange dimensions Flansch-Abmessung Dimensions de la bride						bouten bolting Schrauben boulons			± Kg	
NB	OD tube	D	b1	k	d	d5	a	nr	diam.	d2	St/pc	St 37
NW	AD Rohr											
DN	DE Tube											
20	26,9	105	14,0	75	48	30	3	4	M 12	13,5	0,26	X
25	33,7	115	16,0	85	53	37	3	4	M 12	13,5	0,33	X
32	42,4	140	16,5	100	68	46	3	4	M 16	17,5	0,46	X
40	48,3	150	17,5	110	77	54	4	4	M 16	17,5	0,66	X
50	60,3	156	19,5	125	91	65	4	4	M 16	17,5	0,81	X
65	76,1	185	21,0	145	108	81	4	4	M 16	17,5	0,98	X

EN Flenzen**EN Flanges****EN Flanschen****EN Brides****Spec. 001**

Flenzen met toleranties en merken volgens EN 1092. Keuringsrapport volgens EN 10204/3.1 met AD W2 en AD W9.

Bevestiging van de bestendigheid tegen interkristallijne corrosie volgens ISO 3651-2 en 100% PMI d.m.v. spectrograph.

Flanges with tolerances and marking acc. to EN 1092. Inspection certificate as per EN 10204/3.1 with AD W2/W9.

Confirmation of the resistance to intergranular corrosion acc. to ISO 3651-2 and 100% PMI tested by spectrograph.

Flanschen mit Toleranzen und Markierung nach EN 1092. Abnahmeprüfzeugnis nach EN 10204/3.1 mit AD W2 und AD W9.

Bestätigung der Beständigkeit gegen Interkristalline Korrosion nach ISO 3651-2 und 100 % Verwechslungsprüfung durch Spectrograph.

Brides avec tolérance et marquage conformes à la norme EN 1092. Certificat d'inspection selon la norme EN 10204/3.1 avec AD W2/W9.

Confirmation de la résistance à la corrosion intergranulaire conformément à la norme ISO 3651-2 et test PMI à 100 %

par spectrographe.

DN \ PN	2,5	6	10	16	25	40	63	100	
10	Maten als PN 6		Maten als PN 40	Maten als PN 40	Maten als PN 40		Maten als PN 100		
15									
20									
25									
32									
40									
50			Maten als PN 16						
65									
80									
100									
125									
150									
200									
250									
300									
350									
400									
450									
500									
600									
700									
800									

Overschuifflenzen

EN 1092-1 type 02

Slip-on flanges

EN 1092-1 type 02

Lose/Überschiebflansche

EN 1092-1 type 02

Brides tournantes

EN 1092-1 type 02

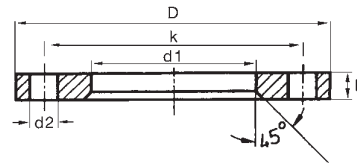

Slip-on flanges

Lose/Überschiebflansche

Brides tournantes

Zie het schema op pagina 74

See diagram at page 74

Sehen Sie bitte das Schema auf Seite 74

Voir le diagramme a la page 74

ND						bouten					
NB						bolting					
NW						Schrauben					
DN						boulons			± Kg	1.4306	
		D	d1	b	k	nr	diam.	d2	St/pc	1.4307	1.4404
PN 10											
200	219,1	340	225	20	295	8	M 20	22	7,46	X	X
250	273,0	395	279	22	350	12	M 20	22	10,30	X	X
300	323,9	445	329	26	400	12	M 20	22	14,00	X	X
400	406,4	565	413	32	515	16	M 24	26	25,00	X	X
PN 16											
50	60,3	165	65	16	125	4	M 16	18	2,20	X	X
65	76,1	185	81	16	145	4	M 16	18	2,62	X	X
80	88,9	200	94	18	160	8	M 16	18	3,32	X	X
100	114,3	220	119	18	180	8	M 16	18	3,67	X	X
125	139,7	250	145	18	210	8	M 16	18	4,54	X	X
150	168,3	285	173	18	240	8	M 20	22	5,60	X	X
200	219,1	340	226	26	295	12	M 20	22	9,37	X	X
250	273,0	405	281	29	355	12	M 24	26	14,36	X	X
300	323,9	460	333	32	410	12	M 24	26	19,18	X	X
PN 40											
15	21,3	95	24	14	65	4	M 12	14	0,69	X	X
20	26,9	105	30	14	75	4	M 12	14	0,81	X	X
25	33,7	115	36	16	85	4	M 12	14	1,11	X	X
32	42,4	140	46	16	100	4	M 16	18	1,64	X	X
40	48,3	150	54	16	110	4	M 16	18	1,86	X	X

Draadflenzen

Threaded flanges

Gewindeflansche

Brides à visser

Draadflenzen

volgens EN 1092-1 type 13

Threaded flanges

according EN 1092-1 type 13

Gewindeflansche

nach EN 1092-1 type 13

Brides à visser

selon la norme EN 1092-1 type 13

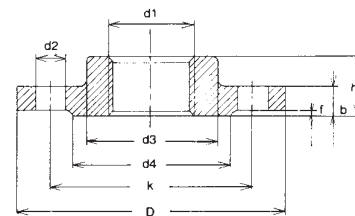

Zie het schema op pagina 74

See diagram at page 74

Sehen Sie bitte das Schema auf Seite 74

Voir le diagramme a la page 74

ND	Uitw. diam.		Flens afmeting							bouten		± Kg	1.4404	
	Pipe size		Flange dimensions							bolting				
NB	Rohranschluss		Flansch-Abmessung							Schrauben		St/pc		
NW	Diam. ex.		Dimensions de la bride							boulons				
DN	d	inches	D	b	k	h1	d3	d4	f	nr	diam.	d2		
PN 16														
15	21,3	1/2"	95	14	65	20	35	45	2	4	M 12	14	0,61	X
20	26,9	3/4"	105	16	75	24	45	58	2	4	M 12	14	0,91	X
25	33,7	1"	115	16	85	24	52	68	2	4	M 12	14	1,10	X
32	42,4	1.1/4"	140	16	100	26	60	78	2	4	M 16	18	1,60	X
40	48,3	1.1/2"	150	16	110	26	70	88	3	4	M 16	18	1,78	X
50	60,3	2"	165	18	125	28	85	102	3	4	M 16	18	2,43	X
65	76,1	2.1/2"	185	18	145	32	105	122	3	4	M 16	18	3,18	X
80	88,9	3"	200	20	160	34	118	138	3	8	M 16	18	4,12	X
100	114,3	4"	220	20	180	38	140	158	3	8	M 16	18	4,47	X

Blindflenzen

volgens EN 1092-1 type 05

Blindflanges

according EN 1092-1 type 05

Blindflansche

nach EN 1092-1 type 05

Brides pleines

selon la norme EN 1092-1 type 05

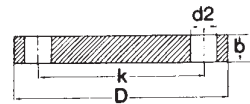

Blindflenzen

Blindflanges

Blindflansche

Brides pleines

Zie het schema op pagina 74

See diagram at page 74

Sehen Sie bitte das Schema auf Seite 74

Voir le diagramme a la page 74

ND NB NW DN	mm	Afmetingen Dimensions Abmessungen Dimensions			bouten bolting Schrauben boulons		d2	± Kg St/pc	1.4306 1.4307	1.4404
		D	b	k	nr	diam.				
PN 10										
200	219,1	340	24	295	8	M 20	22	16,50	X	X
250	273,0	395	26	350	12	M 20	22	24,00	X	X
300	323,9	445	26	400	12	M 20	22	30,90	X	X
350	355,6	505	26	460	16	M 20	22	40,60	X	X
400	406,4	565	26	515	16	M 24	26	49,40	X	X
500	508,0	670	28	620	20	M 24	26	75,00	X	X
600	610,0	780	28	725	20	M 27	30	103,49	X	X
PN 16										
50	60,3	165	18	125	4	M 16	18	2,88	X	X
65	76,1	185	18	145	4	M 16	18	3,66	X	X
80	88,9	200	20	160	8	M 16	18	4,77	X	X
100	114,3	220	20	180	8	M 16	18	5,65	X	X
125	139,7	250	22	210	8	M 16	18	8,42	X	X
150	168,3	285	22	240	8	M 20	22	10,40	X	X
200	219,1	340	24	295	12	M 20	22	16,10	X	X
250	273,0	405	26	355	12	M 24	26	24,90	X	X
300	323,9	460	28	410	12	M 24	26	35,10	X	X
PN 40										
10	17,2	90	14	60	4	M 12	14	0,63		X
15	21,3	95	14	65	4	M 12	14	0,72	X	X
20	26,9	105	16	75	4	M 12	14	1,01	X	X
25	33,7	115	16	85	4	M 12	14	1,23	X	X
32	42,4	140	16	100	4	M 16	18	1,80	X	X
40	48,3	150	16	110	4	M 16	18	2,09	X	X
50	60,3	165	20	125	4	M 16	18	3,20	X	X
65	76,1	185	22	145	8	M 16	18	4,29	X	X
80	88,9	200	24	160	8	M 16	18	5,88	X	X
100	114,3	235	24	190	8	M 20	22	7,54		X
150	168,3	300	28	250	8	M 24	26	14,50	X	X

Vlakke lasflenzen

volgens EN 1092-1 type 01

Flat welding flanges

acc. to EN 1092-1 type 01

Glatte Flansche

nach EN 1092-1 type 01

Brides plates à souder

selon la norme EN 1092-1 type 01

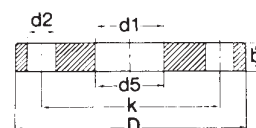

Zie het schema op pagina 74

See diagram at page 74

Sehen Sie bitte das Schema auf Seite 74

Voir le diagramme a la page 74

ND	Uitw.diam	Flens afmetingen in mm			bouten					
NB	Pipe size	Flange dimensions in mm			bolting					
NW	Rohr Anschluss	Flansch-Abmessungen in mm			Schrauben					
DN	Diam. extérieur	Dimensions en mm			boulons					
	d1	D	b	k	nr.	diam.	+/- Kg.	1.4306	1.4307	1.4404
							d2	St./pc.		
PN 10										
200	204,0	340	24	295	8	M 20	22	9,50	X	X
	219,1	340	24	295	8	M 20	22	9,31	X	X
250	254,0	395	26	350	12	M 20	22	13,20	X	X
	273,0	395	26	350	12	M 20	22	11,90	X	X
300	304,0	445	26	400	12	M 20	22	15,00	X	X
	323,9	445	26	400	12	M 20	22	13,80	X	X
350	355,6	505	28	460	16	M 20	22	20,60	X	X
	355,6	505	30	460	16	M 20	22	28		X
400	406,4	565	32	515	16	M 24	26	27,90	X	X
450	457,0	615	36	565	16	M 24	26	33,92	X	X
500	508,0	670	38	620	20	M 24	26	41,10	X	X
600	610,0	780	42	725	20	M 27	30	62,50	X	X
PN 16										
50	54,0	165	18	125	4	M 16	18	2,51	X	X
	50,8	165	20	125	4	M 16	18	2,5	X	X
	57,0	165	18	125	4	M 16	18	2,51		X
	60,3	165	18	125	4	M 16	18	2,47	X	X
65	63,5	185	20	145	4	M 16	18	3,19	X	X
	70,0	185	20	145	4	M 16	18	3,19		X
	76,1	185	18	145	4	M 16	18	3,00	X	X
80	76,1	200	20	160	8	M 16	18	3,50	X	X
	84,0	200	20	160	8	M 16	18	3,90	X	X
	88,9	200	20	160	8	M 16	18	3,79	X	X
100	102,0	235	22	180	8	M 16	18	4,50	X	X
	104,0	220	20	180	8	M 16	18	4,35	X	X
	108,0	220	20	180	8	M 16	18	4,20	X	X
	114,3	220	20	180	8	M 16	18	4,03	X	X
125	129,0	250	22	210	8	M 16	18	5,89	X	X
	133,0	250	22	210	8	M 16	18	5,71	X	
	139,7	250	22	210	8	M 16	18	5,46	X	X
150	154,0	285	22	240	8	M 20	22	6,85	X	X
	159,0	285	22	240	8	M 20	22	6,72	X	X
	168,3	285	22	240	8	M 20	22	6,57	X	X
200	219,1	340	26	295	12	M 20	22	9,73	X	X
250	273,0	405	29	355	12	M 24	26	14,2	X	X
300	323,9	460	32	410	12	M 24	26	19,0	X	X

Vlakke lasflenzen

volgens EN 1092-1 type 01

Flat welding flanges

acc. to EN 1092-1 type 01

Glatte Flansche

nach EN 1092-1 type 01

Brides plates à souder

selon la norme EN 1092-1 type 01

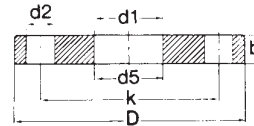

Vlakke lasflenzen

Flat welding
flanges

Glatte Flansche

Brides plates
à souder

Zie het schema op pagina 74

See diagram at page 74

Sehen Sie bitte das Schema auf Seite 74

Voir le diagramme à la page 74

ND	Uitw.diam	Flens afmetingen in mm			bouten bolting Schrauben boulons	diam.	+/- Kg.	1.4306 St./pc.	1.4307	1.4404
		DN	Pipe size	Rohr Anschluss						
PN 40										
10	17,2	90	14	60	4	M 12	14	0,61		X
15	21,3	95	14	65	4	M 12	14	0,67	X	X
20	26,9	105	16	75	4	M 12	14	0,94	X	X
25	30,0	115	16	85	4	M 12	14	1,14		X
	33,7	115	16	85	4	M 12	14	1,11	X	X
32	42,4	140	16	100	4	M 16	18	1,62	X	X
40	44,5	150	16	110	4	M 16	18	1,89		X
	48,3	150	16	110	4	M 16	18	1,86	X	X

Voorlasflenzen

volgens EN 1092-1 type 11

Welding-neck flanges

acc. to EN 1092-1 type 11

Vorschweissflansche

nach EN 1092-1 type 11

Brides à collerette

conformément à la norme EN 1092-1 type 11

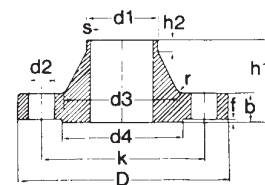

Zie het schema op pagina 74
See diagram at page 74
Sehen Sie bitte das Schema auf Seite 74
Voir le diagramme a la page 74

ND	Flens afmetingen in mm											bouten		+/- Kg.	1.4541	1.4571	1.4306	1.4404	
	NB	Flange dimensions in mm											bolting						
NW		Flansch-Abmessungen in mm											Schrauben		d2	St./pc.	1.4541	1.4571	1.4306
	DN	Dimensions en mm											boulons						
		d1	D	b	h1	d3	s	r	h2	d4	f	k	nr.	diam.					
PN 10																			
200	219,1	340	24	62	235	5,9	10	16	268	3	295	8	M 20	22	11,30	X	X	X	X
250	273,1	395	26	68	292	6,3	12	16	320	3	350	12	M 20	22	14,70	X	X	X	X
300	323,9	445	26	68	344	7,1	12	16	370	4	400	12	M 20	22	17,40	X	X	X	X
350	355,6	505	26	68	385	7,1	12	16	430	4	460	16	M 20	22	23,60		X	X	X
400	406,4	565	26	72	440	7,1	12	16	482	4	515	16	M 24	26	28,60		X	X	X
500	508,0	670	28	75	542	7,1	12	16	585	4	620	20	M 24	26	38,10		X	X	X
600	610,0	780	28	80	642	7,1	12	18	685	5	725	20	M 27	30	44,60		X	X	X
PN 16																			
50	54,0	165	18	45	69	2,9	6	8	102	3	125	4	M 16	18	2,53				X
50	60,3	165	18	45	75	2,9	6	8	102	3	125	4	M 16	18	2,53		X	X	X
65	70,0	185	18	45	84	2,9	6	10	122	3	145	4	M 16	18	3,06			X	X
65	76,1	185	18	45	90	2,9	6	10	122	3	145	4	M 16	18	3,06		X	X	X
80	88,9	200	20	50	105	3,2	8	10	138	3	160	8	M 16	18	3,70	X	X	X	X
100	104,0	220	20	52	121	3,6	8	12	158	3	180	8	M 16	18	4,62			X	X
100	114,3	220	20	52	131	3,6	8	12	158	3	180	8	M 16	18	4,62	X	X	X	X
125	133,0	250	22	55	150	4,0	8	12	188	3	210	8	M 16	18	6,30				X
125	139,7	250	22	55	156	4,0	8	12	188	3	210	8	M 16	18	6,30	X	X	X	X
150	154,0	285	22	55	170	4,5	10	12	212	3	240	8	M 20	22	7,75				X
150	159,0	285	22	55	175	4,5	10	12	212	3	240	8	M 20	22	7,75			X	X
150	168,3	285	22	55	184	4,5	10	12	212	3	240	8	M 20	22	7,75	X	X	X	X
200	219,1	340	24	62	235	5,9	10	16	268	3	295	12	M 20	22	11,00		X	X	X
250	273,1	405	26	70	292	6,3	12	16	320	3	355	12	M 24	26	15,60			X	X
300	323,9	460	28	78	344	7,1	12	16	378	4	410	12	M 24	26	22,00				X
350	355,6	520	30	82	390	8,0	12	16	438	4	470	16	M 24	26	31,20			X	X
400	406,4	580	32	85	445	8,0	12	16	490	4	525	16	M 27	30	39,30			X	X
500	508,0	715	34	90	548	8,0	12	16	610	4	650	20	M 30	33	61,00				X

Voorlasflenzen

volgens EN 1092-1 type 11 PN 25/40

Welding-neck flanges

acc. to EN 1092-1 type 11 PN 25/40

Vorschweissflansche

nach EN 1092-1 type 11 PN 25/40

Brides à collerette

conformément à la norme EN 1092-1 type 11 PN 25/40

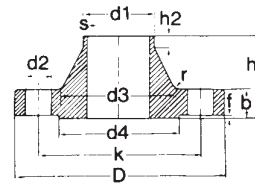

Welding-neck flanges

Vorschweissflansche

Brides à collerette

Zie het schema op pagina 74

See diagram at page 74

Sehen Sie bitte das Schema auf Seite 74

Voir le diagramme à la page 74

ND NB NW DN	Flens afmetingen in mm Flange dimensions in mm Flansch-Abmessungen in mm Dimensions en mm											bouten bolting Schrauben boulons		+/- Kg. St./pc.	1.4541	1.4571	1.4306 1.4307	1.4404	
	d1	D	b	h1	d3	s	r	h2	d4	f	k	nr.	diam.						d2
PN 25																			
200	219,1	360	30	80	244	6,3	10	16	278	3	310	12	M 24	26	17,00	X		X	X
250	273,0	425	32	88	298	7,1	12	18	335	3	370	12	M 27	30	24,40	X			X
300	323,9	485	34	92	352	8,0	12	18	395	4	430	16	M 27	30	31,80			X	X
PN 40																			
10	17,2	90	16	35	28	1,8	4	6	40	2	60	4	M 12	14	0,66				X
15	21,3	95	16	38	32	2,0	4	6	45	2	65	4	M 12	14	0,75	X	X	X	X
20	26,9	105	18	40	40	2,3	4	6	58	2	75	4	M 12	14	1,06		X	X	X
25	33,7	115	18	40	46	2,6	4	6	68	2	85	4	M 12	14	1,29	X	X	X	X
32	42,4	140	18	42	56	2,6	6	6	78	2	100	4	M 16	18	1,88			X	X
40	48,3	150	18	45	64	2,6	6	7	88	3	110	4	M 16	18	2,33	X	X	X	X
50	60,3	165	20	48	75	2,9	6	8	102	3	125	4	M 16	18	2,82	X	X	X	X
65	76,1	185	22	52	90	2,9	6	10	122	3	145	8	M 16	18	3,74			X	X
80	88,9	200	24	58	105	3,2	8	12	138	3	160	8	M 16	18	4,75		X	X	X
100	114,3	235	24	65	134	3,6	8	12	162	3	190	8	M 20	22	6,52		X	X	X
125	139,7	270	26	68	162	4,0	8	12	188	3	220	8	M 24	26	9,07				X
150	168,3	300	28	75	192	4,5	10	12	218	3	250	8	M 24	26	11,80		X	X	X
200	219,1	375	34	88	244	6,3	10	16	285	3	320	12	M 27	30	21,50			X	X
250	273,0	450	38	105	306	7,1	12	18	345	3	385	12	M 30	33	34,90			X	

Voorlasflenzen

volgens EN 1092-1

Welding-neck flanges

acc. to EN 1092-1

Vorschweissflansche

nach EN 1092-1

Brides à collerette

conformément à la norme EN 1092-1

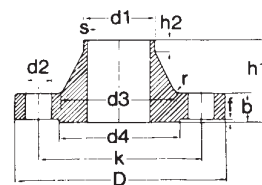

Zie het schema op pagina 74

See diagram at page 74

Sehen Sie bitte das Schema auf Seite 74

Voir le diagramme à la page 74

ND NB NW DN	Flens afmetingen in mm Flange dimensions in mm Flansch-Abmessungen in mm Dimensions en mm											bouten bolting Schrauben boulons		+/- Kg.	1.4306 1.4307	1.4404	
	d1	D	b	h1	d3	s	r	h2	d4	f	k	nr.	diam.				d2
PN 63																	
80	88,9	215	28	72	112	3,6	8	12	138	3	170	8	M 20	22	6,69		X
PN 100																	
15	21,3	105	20	45	34	2,0	4	6	45	2	75	4	M 12	14	1,19		X
25	33,7	140	24	58	52	2,6	4	8	68	2	100	4	M 16	18	2,66	X	X
40	48,3	170	26	62	70	2,9	6	10	88	3	125	4	M 20	22	4,09	X	X
50	60,3	180	26	62	82	2,9	6	10	102	3	135	4	M 20	22	4,55	X	X
65	76,1	205	26	68	98	3,2	6	12	122	3	160	8	M 20	22	5,73		X
100	114,3	250	30	78	138	4,0	8	12	162	3	200	8	M 24	26	9,66	X	X

ASTM Flenzen

ASTM Flanges

ASTM Flanschen

ASTM Brides

ASTM Flenzen

ASTM Flanges

ASTM Flanschen

ASTM Brides

Spec. 001

Gesmede flenzen volgens ASTM A182 en ASME B16.5.

Keuringsrapport volgens EN 10204/3.1B tweevoudig gecertificeerd.

Bestendigheid tegen interkristallijne corrosie volgens ASTM A262 pr. E en 100% PMI d.m.v. spectrograph.

Hardheid HRC max. 22 volgens NACE MR01-75.

Ruwheid pakkingvlak 125 - 250 rms.

Forged flanges acc. to ASTM A182 and ASME B16.5.

Inspection certificate as per EN 10204/3.1B dual certified.

Resistance to intergranular corrosion acc to ASTM A262 pr E and 100% PMI tested by spectrograph.

Hardness HRC max. 22 acc. to NACE MR01-75.

Facing finish 125 - 250 rms.

Geschmiedete Flanschen nach ASTM A182 und ASME B16.5.

Abnahmeprüfzeugnis nach EN 10204/3.1B zweifach zertifiziert.

Beständigkeit gegen Interkristalline Korrosion nach ASTM A262 pr. E und 100 % Verwechslungsprüfung durch Spectrograph.

Härte HRC max. 22 nach NACE MR01-75.

Rauhigkeit der Dichtfläche 125 - 250 rms.

Brides forgées conformes aux normes ASTM A182 et ASME B16.5.

Certificat d'inspection selon la norme EN 10204/3.1B. Double certification.

Résistance à la corrosion intergranulaire vérifiée conformément à la norme ASTM A262 pr. E. Test PMI à 100 % par spectrographe.

Dureté HRC 22 max., conformément à la norme NACE MR01-75.

Finition de face : 125 – 250 mr.

Welding neck flenzen

Welding neck flanges

Vorschweissflansche

Brides à colerette

Welding neck flenzen RF 150 lbs

volgens ASTM A 182/ANSI B 16.5

Welding neck flanges RF 150 lbs

acc. to ASTM A 182/ANSI B 16.5

Vorschweissflansche RF 150 lbs

nach ASTM A 182/ANSI B 16.5

Brides à colerette RF 150 lbs

conformément à la norme ASTM A 182/ANSI B 16.5

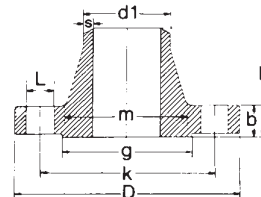

Omschrijving op pagina 83
Description on page 83
Umschreibung auf Seite 83
Description à la page 83

Buis diam. Pipe size Rohrdurchmesser Diam. Tube	Flens afmetingen in mm Flange dimensions in mm Flansch-Abmessungen in mm Dimensions en mm							bouten bolting Schrauben boulons			+/- Kg. St./pc.	304(L)	316(L)
	D	b	g	m	d1	h	s	nr.	L	k			
	1/2" Sch 10 S	88,9	11,1	34,9	30,2	21,3	47,6	2,11	4	15,9			
1/2" Sch 40 S STD	88,9	11,1	34,9	30,2	21,3	47,6	2,77	4	15,9	60,3	0,70	X	X
1/2" Sch 80 S XS	88,9	11,1	34,9	30,2	21,3	47,6	3,73	4	15,9	60,3	0,70	X	X
3/4" Sch 10 S	98,4	12,7	42,9	38,1	26,7	52,4	2,11	4	15,9	69,8	0,80	X	X
3/4" Sch 40 S STD	98,4	12,7	42,9	38,1	26,7	52,4	2,87	4	15,9	69,8	0,80	X	X
3/4" Sch 80 S XS	98,4	12,7	42,9	38,1	26,7	52,4	3,91	4	15,9	69,8	0,80	X	X
1" Sch 10 S	107,9	14,3	50,8	49,2	33,4	55,6	2,77	4	15,9	79,4	1,10	X	X
1" Sch 40 S STD	107,9	14,3	50,8	49,2	33,4	55,6	3,38	4	15,9	79,4	1,10	X	X
1" Sch 80 S XS	107,9	14,3	50,8	49,2	33,4	55,6	4,55	4	15,9	79,4	1,10	X	X
1.1/4" Sch 10 S	117,5	15,9	63,5	58,7	42,2	57,1	2,77	4	15,9	88,9	1,50	X	X
1.1/4" Sch 40 S STD	117,5	15,9	63,5	58,7	42,2	57,1	3,56	4	15,9	88,9	1,50	X	X
1.1/2" Sch 10 S	127,0	17,5	73,0	65,1	48,3	61,9	2,77	4	15,9	98,4	1,80	X	X
1.1/2" Sch 40 S STD	127,0	17,5	73,0	65,1	48,3	61,9	3,68	4	15,9	98,4	1,80	X	X
1.1/2" Sch 80 S XS	127,0	17,5	73,0	65,1	48,3	61,9	5,08	4	15,9	98,4	1,80	X	X
2" Sch 10 S	152,4	19,1	92,1	77,8	60,3	63,5	2,77	4	19,0	120,6	2,70	X	X
2" Sch 40 S STD	152,4	19,1	92,1	77,8	60,3	63,5	3,91	4	19,0	120,6	2,70	X	X
2" Sch 80 S XS	152,4	19,1	92,1	77,8	60,3	63,5	5,54	4	19,0	120,6	2,70	X	X
2.1/2" Sch 10 S	177,8	22,2	104,8	90,5	73,1	69,8	3,05	4	19,0	139,7	4,40	X	X
2.1/2" Sch 40 S STD	177,8	22,2	104,8	90,5	73,1	69,8	5,16	4	19,0	139,7	4,40	X	X
3" Sch 10 S	190,5	23,8	127,0	107,9	88,9	69,8	3,05	4	19,0	152,4	5,20	X	X
3" Sch 40 S STD	190,5	23,8	127,0	107,9	88,9	69,8	5,49	4	19,0	152,4	5,20	X	X
3" Sch 80 S XS	190,5	23,8	127,0	107,9	88,9	69,8	7,62	4	19,0	152,4	5,20	X	X
4" Sch 10 S	229,6	23,8	157,2	134,9	114,3	76,2	3,05	8	19,0	190,5	7,50	X	X
4" Sch 40 S STD	228,6	23,8	157,2	134,9	114,3	76,2	6,02	8	19,0	190,5	7,50	X	X
4" Sch 80 S XS	228,6	23,8	157,2	134,9	114,3	76,2	8,56	8	19,0	190,5	7,50	X	X
5" Sch 10 S	254,0	23,8	185,7	163,5	141,3	88,9	3,40	8	22,2	215,9	9,20	X	X
5" Sch 40 S STD	254,0	23,8	185,7	163,5	141,3	88,9	6,55	8	22,2	215,9	9,20	X	X
6" Sch 10 S	279,4	25,4	215,9	192,1	168,3	88,9	3,40	8	22,2	241,3	11,00	X	X
6" Sch 40 S STD	279,4	25,4	215,9	192,1	168,3	88,9	7,11	8	22,2	241,3	11,00	X	X
6" Sch 80 S XS	279,4	25,4	215,9	192,1	168,3	88,9	10,97	8	22,2	241,3	11,00	X	X
8" Sch 10 S	342,9	28,6	269,9	246,1	219,1	101,6	3,76	8	22,2	298,5	18,40	X	X
8" Sch 40 S STD	342,9	28,6	269,9	246,1	219,1	101,6	8,18	8	22,2	298,5	18,40	X	X
8" Sch 80 S XS	342,9	28,6	269,9	246,1	219,1	101,6	12,7	8	22,2	298,5	18,40	X	X
10" Sch 10 S	406,4	30,2	323,9	304,8	273,0	101,6	4,19	12	25,4	361,9	25,50	X	X
10" Sch 40 S STD	406,4	30,2	323,9	304,8	273,0	101,6	9,27	12	25,4	361,9	25,50	X	X
10" Sch 80 S XS	406,4	30,2	323,9	304,8	273,0	101,6	12,70	12	25,4	361,9	25,50	X	X
12" Sch 10 S	482,8	31,8	381,0	365,1	323,9	114,3	4,57	12	25,4	431,8	37,00	X	X
12" Sch 40 S STD	482,8	31,8	381,0	365,1	323,9	114,3	9,53	12	25,4	431,8	37,00	X	X
14" Sch 10 S	533,4	35,1	412,8	400,1	355,6	127,0	4,78	12	28,5	476,2	51,00	X	X
14" Sch 40 S STD	533,4	35,1	412,8	400,1	355,6	127,0	9,53	12	28,5	476,2	51,00	X	X

Welding neck flenzen

Welding neck flanges

Vorschweissflansche

Brides à collerette

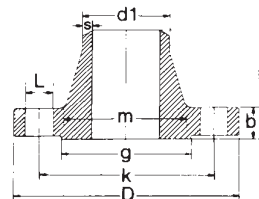

Omschrijving op pagina 83
Description on page 83
Umschreibung auf Seite 83
Description à la page 83

Buis diam. Pipe size Rohrdurchmesser Diam. Tube	Flens afmetingen in mm Flange dimensions in mm Flansch-Abmessungen in mm Dimensions en mm							bouten bolting Schrauben boulons			+/- Kg. St./pc.	304(L)	316(L)
	D	b	g	m	d1	h	s	nr.	L	k			
	16" Sch 10 S	596,9	36,6	469,9	457,2	406,4	127,0	4,78	16	28,5			
16" Sch 40 S STD	596,9	36,6	469,9	457,2	406,4	127,0	9,53	16	28,5	539,7	61,50	X	X
18" Sch 10 S	635,0	39,6	533,4	505,0	457,2	139,7	4,78	16	32,0	577,8	71,50	X	X
20" Sch 10 S	698,5	42,9	584,2	558,8	508,0	144,5	5,54	20	32,0	635,0	85,00	X	X
20" Sch 40 S STD	698,5	42,9	584,2	558,8	508,0	144,5	9,53	20	32,0	635,0	85,00	X	X
24" Sch 10 S	812,8	47,8	692,2	663,4	609,6	152,4	6,35	20	35,0	749,3	119,00	X	X
24" Sch 20 S STD	812,8	47,8	692,2	663,4	609,6	152,4	9,53	20	35,0	749,3	119,00	X	X
24" Sch 40 S STD	812,8	47,8	692,2	663,4	609,6	152,4	9,53	20	35,0	749,3	119,00	X	X

Welding neck flenzen RF 300 lbs

volgens ASTM A 182/ANSI B 16.5

Welding neck flanges RF 300 lbs

acc. to ASTM A 182/ANSI B 16.5

Vorschweissflansche RF 300 lbs

nach ASTM A 182/ANSI B 16.5

Brides à collerette RF 300 lbs

conformément à la norme ASTM A 182/ANSI B 16.5

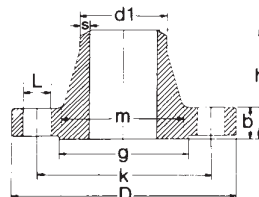

Buis diam. Pipe size Rohrdurchmesser Diam. Tube	Flens afmetingen in mm Flange dimensions in mm Flansch-Abmessungen in mm Dimensions en mm							bouten bolting Schrauben boulons			+/- Kg. St./pc.	304(L)	316(L)
	D	b	g	m	d1	h	s	nr.	L	k			
	1/2" Sch 10 S	95,2	14,3	34,9	38,1	21,3	52,4	2,11	4	15,9			
1/2" Sch 40 S STD	95,2	14,3	34,9	38,1	21,3	52,4	2,77	4	15,9	66,7	0,80	X	X
1/2" Sch 80 S XS	95,2	14,3	34,9	38,1	21,3	52,4	3,73	4	15,9	66,7	0,80	X	X
1/2" Sch 160	95,2	14,3	34,9	38,1	21,3	52,4	4,75	4	15,9	66,7	0,80		X
3/4" Sch 10 S	117,5	15,9	42,9	47,6	26,7	57,1	2,11	4	19,1	82,5	1,40	X	X
3/4" Sch 40 S STD	117,5	15,9	42,9	47,6	26,7	57,1	2,87	4	19,1	82,5	1,40	X	X
3/4" Sch 80 S XS	117,5	15,9	42,9	47,6	26,7	57,1	3,91	4	19,1	82,5	1,40	X	X

Welding neck flenzen

Welding neck flanges

Vorschweissflansche

Brides à collerette

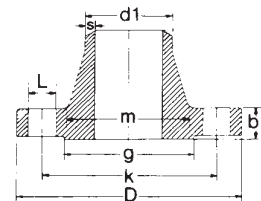

Omschrijving op pagina 83
Description on page 83
Umschreibung auf Seite 83
Description à la page 83

Buis diam. Pipe size Rohrdurchmesser Diam. Tube	Flens afmetingen in mm Flange dimensions in mm Flansch-Abmessungen in mm Dimensions en mm							bouten bolting Schrauben Schrauben boulons			+/- Kg. St./pc.	304(L)	316(L)
	D	b	g	m	d1	h	s	nr.	L	k			
	1" Sch 10 S	123,8	17,5	50,8	54,0	33,4	61,9	2,77	4	19,1			
1" Sch 40 S STD	123,8	17,5	50,8	54,0	33,4	61,9	3,38	4	19,1	88,9	1,70	X	X
1" Sch 80 S XS	123,8	17,5	50,8	54,0	33,4	61,9	4,55	4	19,1	88,9	1,70	X	X
1.1/4" Sch 40 S STD	133,4	19,1	63,5	63,5	42,2	65,1	3,56	4	19,1	98,4	2,20	X	X
1.1/2" Sch 10 S	155,6	20,6	73,0	69,8	48,3	68,3	2,77	4	22,2	114,3	3,20	X	X
1.1/2" Sch 40 S STD	155,6	20,6	73,0	69,8	48,3	68,3	3,68	4	22,2	114,3	3,20	X	X
1.1/2" Sch 80 S XS	155,6	20,6	73,0	69,8	48,3	68,3	5,08	4	22,2	114,3	3,20	X	X
2" Sch 10 S	165,1	22,2	92,1	84,1	60,3	69,8	2,77	8	19,1	127,0	3,60	X	X
2" Sch 40 S STD	165,1	22,2	92,1	84,1	60,3	69,8	3,91	8	19,1	127,0	3,60	X	X
2" Sch 80 S XS	165,1	22,2	92,1	84,1	60,3	69,8	5,54	8	19,1	127,0	3,60	X	X
2.1/2" Sch 40 S STD	190,5	25,4	104,8	100,0	73,1	76,2	5,16	8	22,2	149,2	5,40	X	X
3" Sch 10 S	209,5	28,6	127,0	117,5	88,9	79,4	3,05	8	22,2	168,3	7,30	X	X
3" Sch 40 S STD	209,5	28,6	127,0	117,5	88,9	79,4	5,49	8	22,2	168,3	7,30	X	X
4" Sch 10 S	254,0	31,8	157,2	146,1	114,3	85,7	3,05	8	22,2	200,0	11,80	X	X
4" Sch 40 S STD	254,0	31,8	157,2	146,1	114,3	85,7	6,02	8	22,2	200,0	11,80	X	X
4" Sch 80 S XS	254,0	31,8	157,2	146,1	114,3	85,7	8,56	8	22,2	200,0	11,80	X	X
6" Sch 10 S	317,5	36,5	215,9	206,4	168,3	98,4	3,40	12	22,2	269,9	20,20	X	X
6" Sch 40 S STD	317,5	36,5	215,9	206,4	168,3	98,4	7,11	12	22,2	269,9	20,20	X	X
6" Sch 80 S XS	317,5	36,5	215,9	206,4	168,3	98,4	10,97	12	22,2	269,9	20,20	X	X
8" Sch 10 S	381,0	41,3	269,9	260,4	219,1	111,1	3,76	12	25,4	330,2	31,20	X	X
8" Sch 40 S STD	381,0	41,3	269,9	260,4	219,1	111,1	8,18	12	25,4	330,2	31,20	X	X
8" Sch 80 S XS	381,0	41,3	269,9	260,4	219,1	111,1	12,70	12	25,4	330,2	31,20	X	X
10" Sch 10 S	444,5	47,6	323,9	320,7	273,0	117,5	4,19	16	28,6	387,3	44,30	X	X
10" Sch 20S	444,5	47,6	323,9	320,7	273,0	117,5	6,35	16	28,6	387,3	44,30	X	X
10" Sch 40 S STD	444,5	47,6	323,9	320,7	273,0	117,5	9,27	16	28,6	387,3	44,30	X	X
10" Sch 80 S XS	444,5	47,6	323,9	320,7	273,0	117,5	12,70	16	28,6	387,3	44,30	X	X
12" Sch 10 S	520,7	50,8	381,0	374,6	323,9	130,2	4,57	16	31,7	450,8	63,50	X	X
12" Sch 40 S STD	520,7	50,8	381,0	374,6	323,9	130,2	9,53	16	31,7	450,8	63,50	X	X
12" Sch 80 S XS	520,7	50,8	381,0	374,6	323,9	130,2	12,70	16	31,7	450,8	63,50	X	X
14" Sch 40 S STD	584,2	53,8	412,8	425,5	355,6	142,7	9,53	20	31,7	514,3	86,00	X	X
16" Sch 40 S STD	647,7	57,2	469,9	482,6	406,4	146,1	9,53	20	35,0	571,5	112,00	X	X
16" Sch 80 S XS	647,7	57,2	469,9	482,6	406,4	146,1	12,70	20	35,0	571,5	112,00	X	X

Welding neck flenzen RF 600 lbs

volgens ASTM A 182/ANSI B 16.5

Welding neck flanges RF 600 lbs

acc. to ASTM A 182/ANSI B 16.5

Vorschweissflansche RF 600 lbs

nach ASTM A 182/ANSI B 16.5

Brides à collerette RF 600 lbs

conformément à la norme ASTM A 182/ANSI B 16.5

Omschrijving op pagina 83

Description on page 83

Umschreibung auf Seite 83

Description à la page 83

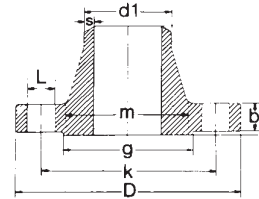

Welding neck flenzen

Welding neck flanges

Vorschweissflansche

Brides à collerette

Buis diam. Pipe size Rohrdurchmesser Diam. Tube	Flens afmetingen in mm Flange dimensions in mm Flansch-Abmessungen in mm Dimensions en mm							bouten bolting Schrauben Schrauben boulons			+/- Kg. St./pc.	304(L)	316(L)
	D	b	g	m	d1	h	s	nr.	L	k			
	1/2" Sch 40	95,2	14,3	34,9	38,1	21,3	52,4	2,77	4	15,9			
1/2" Sch 80	95,2	14,3	34,9	38,1	21,3	52,4	3,73	4	15,9	66,7	0,90	X	X
1/2" Sch 160	95,2	14,3	34,9	38,1	21,3	52,4	2,77	4	15,9	66,7	0,90		X
3/4" Sch 40	117,5	15,9	42,9	47,6	26,7	57,1	2,87	4	19,1	82,5	1,60	X	X
3/4" Sch 80	117,5	15,9	42,9	47,6	26,7	57,1	3,91	4	19,1	82,5	1,60		X
3/4" Sch 160	117,5	15,9	42,9	47,6	26,7	57,1	3,91	4	19,1	82,5	1,60		X
1" Sch 10 S	123,8	17,5	50,8	54,0	33,4	61,9	2,77	4	19,1	88,9	1,90	X	X
1" Sch 40 S	123,8	17,5	50,8	54,0	33,4	61,9	3,38	4	19,1	88,9	1,90	X	X
1" Sch 80 S XS	123,8	17,5	50,8	54,0	33,4	61,9	4,55	4	19,1	88,9	1,90	X	X
1.1/4" Sch 40 S STD	133,4	20,6	63,5	63,5	42,2	66,7	3,56	4	19,1	98,4	2,60		X
1.1/2" Sch 40 S STD	155,6	22,2	73,0	69,8	48,3	69,8	3,68	4	22,2	114,3	3,60	X	X
1.1/2" Sch 80 S XS	155,6	22,2	73,0	69,8	48,3	69,8	5,08	4	22,2	114,3	3,60	X	X
2" Sch 10 S	165,1	25,4	92,1	84,1	60,3	73,0	2,77	8	19,1	127,0	4,70	X	
2" Sch 40 S STD	165,1	25,4	92,1	84,1	60,3	73,0	3,91	8	19,1	127,0	4,70	X	X
2" Sch 80 S XS	165,1	25,4	92,1	84,1	60,3	73,0	5,54	8	19,1	127,0	4,70	X	X
2.1/2" Sch 40 S STD	190,0	28,6	104,8	100,0	73,0	79,0	5,16	8	22,2	149,2	4,70	X	X
3" Sch 40 S STD	209,5	31,7	127,0	117,5	88,9	82,5	5,49	8	22,2	168,3	8,70	X	X
3" Sch 80 S XS	209,5	31,7	127,0	117,5	88,9	82,5	7,62	8	22,2	168,3	8,70	X	X
4" Sch 40 S STD	273,0	38,1	157,2	152,4	114,3	101,6	6,02	8	25,4	215,9	18,40	X	X
4" Sch 80 S XS	273,0	38,1	157,2	152,4	114,3	101,6	8,56	8	25,4	215,9	18,40	X	X
6" Sch 40 S STD	355,6	47,6	215,9	222,2	168,3	117,5	7,11	12	28,6	292,1	37,00	X	X
6" Sch 80 S XS	355,6	47,6	215,9	222,2	168,3	117,5	10,97	12	28,6	292,1	37,00	X	X

Welding neck flenzen

Welding neck flanges

Vorschweissflansche

Brides à colerette

Welding neck flenzen RF 1500 lbs

volgens ASTM A 182/ANSI B 16.5

Welding neck flanges RF 1500 lbs

acc. to ASTM A 182/ANSI B 16.5

Vorschweissflansche RF 1500 lbs

nach ASTM A 182/ANSI B 16.5

Brides à colerette RF 1500 lbs

conformément à la norme ASTM A 182/ANSI B 16.5

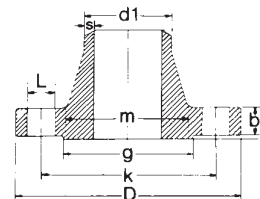

Omschrijving op pagina 83
 Description on page 83
 Umschreibung auf Seite 83
 Description à la page 83

Buis diam. Pipe size Rohrdurchmesser Diam. Tube	Flens afmetingen in mm Flange dimensions in mm Flansch-Abmessungen in mm Dimensions en mm							bouten bolting Schrauben boulons			+/- Kg. St./pc.	304(L)	316(L)
	D	b	g	m	d1	h	s	nr.	L	k			
	1/2" Sch 80 S XS	120,7	22,4	34,9	38,1	21,3	60,5	3,73	4	22,5			
1/2" Sch 160	120,7	22,4	34,9	38,1	21,3	60,5	4,75	4	22,5	82,5	2,10		X
1/2" XXS	120,7	22,4	34,9	38,1	21,3	60,5	7,47	4	22,5	82,5	2,10		X
3/4" Sch 40 S STD	130,0	25,4	42,9	44,5	26,7	69,9	2,87	4	22,5	88,9	2,70		X
3/4" Sch 80 S XS	130,0	25,4	42,9	44,5	26,7	69,9	3,91	4	22,5	88,9	2,70	X	X
3/4" Sch 120	130,0	25,4	42,9	44,5	26,7	69,9	3,91	4	22,5	88,9	2,70		X
1" Sch 40 S STD	149,4	28,4	50,8	52,3	33,4	73,2	3,38	4	25,4	101,6	3,90	X	X
1" Sch 80 S XS	149,4	28,4	50,8	52,3	33,4	73,2	4,55	4	25,4	101,6	3,90	X	X
1" Sch 160	149,4	28,4	50,8	52,3	33,4	73,2	6,35	4	25,4	101,6	3,90	X	X
1.1/2" Sch 80 S XS	177,8	31,8	73	69,9	48,3	82,3	5,08	4	28,5	123,8	6,20		X
2" Sch 40 S STD	215,9	38,1	92,1	104,6	60,3	101,6	3,91	8	25,5	165,1	11,30	X	X
2" Sch 80 S XS	215,9	38,1	92,1	104,6	60,3	101,6	5,54	8	25,5	165,1	11,30	X	X

Slip-on flenzen RF 150 lbs

volgens ASTM A 182/ANSI B 16.5

Slip-on flanges RF 150 lbs

acc. to ASTM A 182/ANSI B 16.5

Überschiebflansche RF 150 lbs

nach ASTM A 182/ANSI B 16.5

Brides à emmancher RF 150 lbs

conformément à la norme ASTM A 182/ANSI B 16.5

Omschrijving op pagina 83

Description on page 83

Umschreibung auf Seite 83

Description à la page 83

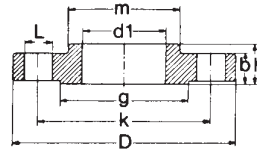

Slip-on flenzen

Slip-on flanges

Überschiebflansche

Brides à emmancher

Buis diam. Pipe size Rohrdurchmesser Diam. Tube	Flens afmetingen in mm Flange dimensions in mm Flansch-Abmessungen in mm Dimensions en mm						bouten bolting Schrauben boulons		k	+/- Kg. St./pc.	304(L)	316(L)
	D	b	g	m	d1	h	nr.	L				
	1/2"	88,9	11,1	34,9	30,2	22,3	15,9	4				
3/4"	98,4	12,7	42,9	38,1	27,7	15,9	4	15,9	69,8	0,70	X	X
1"	107,9	14,3	50,8	49,2	34,5	17,5	4	15,9	79,4	0,80	X	X
1.1/4"	117,5	15,9	63,5	58,7	43,2	20,6	4	15,9	88,9	1,20	X	X
1.1/2"	127,0	17,5	73,0	65,1	49,5	22,6	4	15,9	98,4	1,40	X	X
2"	152,4	19,1	92,1	77,8	62,0	25,4	4	19,0	120,6	2,20	X	X
2.1/2"	177,8	22,2	104,8	90,5	74,7	28,6	4	19,0	139,7	3,50	X	X
3"	190,5	23,8	127,0	107,9	90,7	30,2	4	19,0	152,4	3,80	X	X
3.1/2"	215,9	23,8	139,7	122,2	103,4	31,7	8	19,0	177,8	5,00		X
4"	228,6	23,8	157,2	134,9	116,1	33,3	8	19,0	190,5	5,60	X	X
5"	254,0	23,8	185,7	163,5	143,8	36,5	8	22,2	215,9	6,50	X	X
6"	279,4	25,4	215,9	192,1	170,7	39,7	8	22,2	241,3	8,10	X	X
8"	342,9	28,6	269,9	246,1	221,5	44,4	8	22,2	298,5	13,00	X	X
10"	406,4	30,2	323,9	304,8	276,8	49,2	12	25,4	361,9	18,40	X	X
12"	482,6	31,8	381,0	365,1	327,1	55,6	12	25,4	431,8	28,50	X	X
14"	533,4	35,1	412,8	400,1	359,2	57,2	12	28,5	476,2	37,50	X	X
16"	596,9	36,6	469,9	457,2	410,5	63,5	16	28,5	539,7	44,50	X	X
18"	635,0	39,6	533,4	505,0	461,8	68,3	16	32,0	577,8	54,00	X	X
20"	698,5	42,9	584,2	558,8	513,1	73,2	20	32,0	635,0	72,00	X	X
24"	812,8	47,8	692,2	663,4	616,0	82,6	20	35,0	749,3	95,00	X	X

Slip-on flenzen

Slip-on flanges

Überschiebflansche

Brides à emmancher

Slip-on flenzen RF 300 lbs

volgens ASTM A 182/ANSI B 16.5

Slip-on flanges RF 300 lbs

acc. to ASTM A 182/ANSI B 16.5

Überschiebflansche RF 300 lbs

nach ASTM A 182/ANSI B 16.5

Brides à emmancher RF 300 lbs

conformément à la norme ASTM A 182/ANSI B 16.5

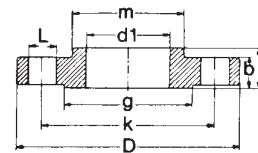

Omschrijving op pagina 83
Description on page 83
Umschreibung auf Seite 83
Description à la page 83

Buis diam. Pipe size Rohrdurchmesser Diam. Tube	Flens afmetingen in mm Flange dimensions in mm Flansch-Abmessungen in mm Dimensions en mm						bouten bolting Schrauben boulons		k	+/- Kg. St./pc.	304(L)	316(L)
	D	b	g	m	d1	h	nr.	L				
	1/2"	95,2	14,3	34,9	38,1	22,3	22,2	4				
3/4"	117,5	15,9	42,9	47,6	27,7	25,4	4	19,1	82,5	1,20	X	X
1"	123,8	17,5	50,8	54,0	34,5	27,0	4	19,1	88,9	1,40	X	X
1.1/4"	133,4	19,1	63,6	63,6	43,2	27,0	4	19,1	98,4	1,80	X	X
1.1/2"	155,6	20,8	73,0	69,8	49,5	30,2	4	22,2	114,3	2,70	X	X
2"	165,1	22,2	92,1	84,1	62,0	33,3	8	19,1	127,0	3,20	X	X
2.1/2"	190,5	25,4	104,8	100,0	74,7	38,1	8	22,2	149,2	4,50	X	
3"	209,5	28,6	127,0	117,5	90,7	42,9	8	22,2	168,3	5,90	X	X
4"	254,0	31,8	157,2	146,1	116,1	47,6	8	22,2	200,0	10,00	X	X
5"	279,4	34,9	185,7	177,8	143,8	50,8	8	22,2	235,0	12,50	X	X
6"	317,5	36,5	215,9	206,4	170,7	52,4	12	22,2	269,9	16,50	X	X
8"	381,0	41,3	269,9	260,4	221,5	61,9	12	26,4	330,2	25,50	X	X
10"	444,5	47,6	323,8	320,7	276,3	66,7	16	28,6	387,3	35,00	X	X
12"	520,7	50,8	381,0	374,6	327,1	73,0	16	31,7	450,8	52,00	X	X

Slip-on flenzen RF 600 lbs

volgens ASTM A 182/ANSI B 16.5

Slip-on flanges RF 600 lbs

acc. to ASTM A 182/ANSI B 16.5

Überschiebflansche RF 600 lbs

nach ASTM A 182/ANSI B 16.5

Brides à emmancher RF 600 lbs

conformément à la norme ASTM A 182/ANSI B 16.5

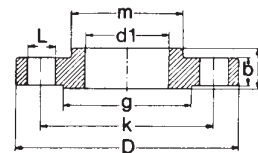

Buis diam. Pipe size Rohrdurchmesser Diam. Tube	Flens afmetingen in mm Flange dimensions in mm Flansch-Abmessungen in mm Dimensions en mm						bouten bolting Schrauben boulons		k	+/- Kg. St./pc.	304(L)	316(L)
	D	b	g	m	d1	h	nr.	L				
	3/4"	117,5	15,9	42,9	47,6	27,7	25,4	4				
1"	123,8	17,5	50,8	54,0	34,5	27,0	4	19,1	88,9	1,70	X	X
1.1/2"	155,4	22,4	73,0	69,8	49,5	31,8	4	22,2	114,3	3,10	X	
2"	165,1	25,4	92,1	84,1	62,0	36,6	8	19,1	127,0	3,90	X	X
3"	209,5	31,8	127,0	117,5	90,7	46,0	8	25,5	168,3	7,30	X	
4"	273,1	38,1	157,2	152,4	116,1	53,8	8	25,5	215,9	16,50	X	

Draad flenzen RF 150 lbs

volgens ASTM A 182/ANSI B 16.5

Screwed flanges RF 150 lbs

acc. to ASTM A 182/ANSI B 16.5

Gewindeflansche RF 150 lbs

nach ASTM A 182/ANSI B 16.5

Brides à visser RF 150 lbs

conformément à la norme ASTM A 182/ANSI B 16.5

Omschrijving op pagina 83

Description on page 83

Umschreibung auf Seite 83

Description à la page 83

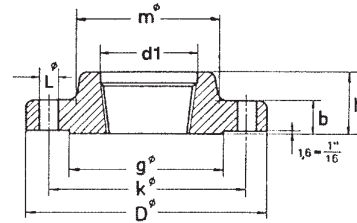

Draad flenzen

Screwed flanges

Gewindeflansche

Brides à visser

Buis diam. Pipe size Rohrdurchmesser Diam. Tube	Flens afmetingen in mm Flange dimensions in mm Flansch-Abmessungen in mm Dimensions en mm						bouten bolting Schrauben boulons		k	+/- Kg. St./pc.	304(L)	316(L)
	D	b	g	m	d1	h	nr.	L				
	1/2"	88,9	11,1	34,9	30,2	1/2"	15,9	4				
3/4"	98,4	12,7	42,9	38,1	3/4"	15,9	4	15,9	69,8	0,70	X	X
1"	107,9	14,3	50,8	49,2	1"	17,5	4	15,9	79,4	0,80	X	X
1.1/2"	127,0	17,5	73,0	65,1	1.1/2"	22,6	4	15,9	98,4	1,50	X	X
2"	152,4	19,1	92,1	77,8	2"	25,4	4	19,0	120,6	2,30		X
3"	190,5	23,8	127,0	107,9	3"	30,2	4	19,0	152,4	4,10		X

Blind flenzen**Blind flanges****Blindflansche****Brides pleines****Blind flenzen RF 150 lbs**

volgens ASTM A 182/ANSI B 16.5

Blind flanges RF 150 lbs

acc. to ASTM A 182/ANSI B 16.5

Blindflansche RF 150 lbs

nach ASTM A 182/ANSI B 16.5

Brides pleines RF 150 lbs

conformément à la norme ASTM A 182/ANSI B 16.5

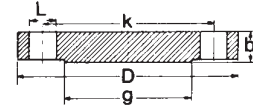

Omschrijving op pagina 83
 Description on page 83
 Umschreibung auf Seite 83
 Description à la page 83

Buis diam. Pipe size Rohrdurchmesser Diam. Tube	Flens afmetingen in mm Flange dimensions in mm Flansch-Abmessungen in mm Dimensions en mm			bouten bolting Schrauben boulons			+/- Kg. St./pc.	304(L)	316(L)
	D	b	g	nr.	L	k			
	1/2"	88,9	11,1	34,9	4	15,9			
3/4"	98,4	12,7	42,9	4	15,9	69,8	0,80	X	X
1"	107,9	14,3	50,8	4	15,9	79,4	0,90	X	X
1.1/4"	117,5	15,9	63,5	4	15,9	88,9	1,30	X	X
1.1/2"	127,0	17,5	73,0	4	15,9	98,4	1,60	X	X
2"	152,4	19,1	92,1	4	19,0	120,6	2,60	X	X
2.1/2"	177,8	22,2	104,8	4	19,0	139,7	4,10	X	X
3"	190,5	23,8	127,0	4	19,0	152,4	5,10	X	X
4"	228,6	23,8	157,2	8	19,0	190,5	7,50	X	X
5"	254,0	23,8	185,7	8	22,2	215,9	9,20		X
6"	279,4	25,4	215,9	8	22,2	241,3	11,80	X	X
8"	342,9	28,6	269,9	8	22,2	298,5	20,40	X	X
10"	406,4	30,2	323,9	12	25,4	361,9	31,00	X	X
12"	482,6	31,8	381,0	12	25,4	431,8	47,00	X	X
14"	533,4	34,9	412,7	12	28,6	476,2	60,00	X	X
16"	596,9	36,6	469,9	16	28,5	539,7	81,00	X	X
20"	698,5	42,9	584,2	20	32,0	635,0	127,00	X	X
24"	812,8	47,8	692,2	20	35,0	749,3	190,00	X	X

Blind flenzen RF 300 lbs

volgens ASTM A 182/ANSI B 16.5

Blind flanges RF 300 lbs

acc. to ASTM A 182/ANSI B 16.5

Blindflansche RF 300 lbs

nach ASTM A 182/ANSI B 16.5

Brides pleines RF 300 lbs

conformément à la norme ASTM A 182/ANSI B 16.5

Omschrijving op pagina 83

Description on page 83

Umschreibung auf Seite 83

Description à la page 83

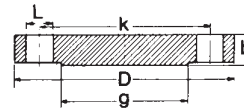

Buis diam. Pipe size Rohrdurchmesser Diam. Tube	Flens afmetingen in mm Flange dimensions in mm Flansch-Abmessungen in mm Dimensions en mm			bouten bolting Schrauben boulons			+/- Kg. St./pc.	304(L)	316(L)
	D	b	g	nr.	L	k			
	1/2"	95,2	14,3	34,9	4	15,9			
3/4"	117,5	15,9	42,9	4	19,1	82,5	1,20	X	X
1"	123,8	17,5	50,8	4	19,1	88,9	1,50	X	X
1.1/2"	155,6	20,8	73,0	4	22,2	114,8	2,90	X	X
2"	165,1	22,2	92,1	8	19,1	127,0	3,50	X	X
3"	209,5	28,6	127,0	8	22,2	168,3	7,20	X	X
4"	254,0	31,8	157,2	8	22,2	200,0	12,20	X	X
6"	317,5	36,5	215,9	12	22,2	269,9	22,00	X	X
8"	381,0	41,3	269,9	12	26,4	330,2	36,00	X	X
10"	444,5	47,6	323,9	16	28,8	387,3	55,00	X	X
12"	520,7	50,8	381,0	16	31,7	450,8	82,50	X	X
14"	584,2	54,0	412,7	20	31,7	514,3	108,00		X

Blind flenzen RF 600 lbs

volgens ASTM A 182/ANSI B 16.5

Blind flanges RF 600 lbs

acc. to ASTM A 182/ANSI B 16.5

Blindflansche RF 600 lbs

nach ASTM A 182/ANSI B 16.5

Brides pleines RF 600 lbs

conformément à la norme ASTM A 182/ANSI B 16.5

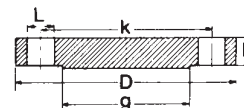

Buis diam. Pipe size Rohrdurchmesser Diam. Tube	Flens afmetingen in mm Flange dimensions in mm Flansch-Abmessungen in mm Dimensions en mm			bouten bolting Schrauben boulons			+/- Kg. St./pc.	304(L)	316(L)
	D	b	g	nr.	L	k			
	1/2"	95,2	14,3	34,9	4	15,9			
3/4"	117,5	15,9	42,9	4	19,1	82,5	1,40	X	X
1"	123,8	17,5	50,8	4	19,1	88,9	1,70	X	X
1.1/2"	155,4	22,4	73,0	4	22,2	114,3	3,40	X	X
2"	165,1	25,4	92,1	8	19,1	127,0	4,40	X	X

Lap - Joint flenzen

Lap - Joint flanges

Lap - Joint Flansche

Brides tournantes

Lap - Joint flenzen FF 150 lbs

volgens ASTM A 182/ANSI B 16.5

Lap - Joint flanges FF 150 lbs

acc. to ASTM A 182/ANSI B 16.5

Lap - Joint Flansche FF 150 lbs

nach ASTM A 182/ANSI B 16.5

Brides tournantes FF 150 lbs

conformément à la norme ASTM A 182/ANSI B 16.5

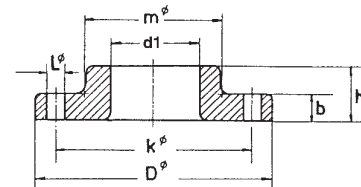

Omschrijving op pagina 83
Description on page 83
Umschreibung auf Seite 83
Description à la page 83

Buis diam. Pipe size Rohrdurchmesser Diam. Tube	Flens afmetingen in mm Flange dimensions in mm Flansch-Abmessungen in mm Dimensions en mm					bouten bolting Schrauben boulons			+/- Kg. St./pc.	304(L)	316(L)
	D	b	m	d1	h	nr.	L	k			
	1/2"	88,9	11,1	30,2	22,9	15,9	4	15,9			
1"	107,9	14,3	49,2	35,1	17,5	4	15,9	79,4	0,80	X	X
1.1/2"	127,0	17,5	65,1	50,0	22,6	4	15,9	98,4	1,40	X	X
2"	152,4	19,1	77,8	62,5	25,4	4	19,0	120,6	2,20	X	X
3"	190,5	23,8	107,9	91,4	30,2	4	19,0	152,4	3,80	X	X
4"	228,6	23,8	134,9	116,8	33,3	8	19,0	190,5	5,60	X	X
6"	279,4	25,4	192,1	171,5	39,7	8	22,2	241,3	8,10	X	X
8"	342,9	28,6	246,1	222,3	44,4	8	22,2	298,5	13,00	X	X
10"	406,4	30,2	304,8	277,4	49,3	12	25,5	361,9	18,40	X	X
14"	533,4	35,1	400,1	360,2	57,2	12	28,5	476,2	41,50	X	

Lap - Joint flenzen FF 300 lbs

volgens ASTM A 182/ANSI B 16.5

Lap - Joint flanges FF 300 lbs

acc. to ASTM A 182/ANSI B 16.5

Lap - Joint Flansche FF 300 lbs

nach ASTM A 182/ANSI B 16.5

Brides tournantes FF 300 lbs

conformément à la norme ASTM A 182/ANSI B 16.5

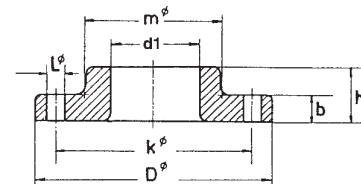

Buis diam. Pipe size Rohrdurchmesser Diam. Tube	Flens afmetingen in mm Flange dimensions in mm Flansch-Abmessungen in mm Dimensions en mm					bouten bolting Schrauben boulons			+/- Kg. St./pc.	304(L)	316(L)
	D	b	m	d1	h	nr.	L	k			
	1/2"	95,2	14,3	38,1	22,9	22,2	4	15,9			
3/4"	117,5	15,9	47,6	28,2	25,4	4	19,1	82,5	1,20	X	X
1"	123,8	17,5	54,0	35,1	27,0	4	19,1	88,9	1,40	X	X
1.1/4"	135	19,1	64,0	43,7	27,0	4	19,1	98,4	1,8	X	X
1.1/2"	155,6	20,8	69,8	50,0	30,2	4	22,2	114,8	2,70	X	X
2"	165,1	22,2	84,1	62,5	33,3	8	19,1	127,0	3,20	X	X
3"	209,5	28,6	117,5	91,4	42,9	8	22,2	168,3	6,00	X	X
4"	254,0	31,8	146,1	116,8	47,6	8	22,2	200,0	10,00	X	X
6"	317,5	36,5	206,4	171,5	52,4	12	22,2	269,9	16,50	X	X
8"	381,0	41,3	260,4	222,3	61,9	12	25,4	330,2	25,50	X	X
10"	444,5	47,6	320,7	277,5	66,7	16	28,6	387,3	35,00	X	
20"	775,0	63,5	587,0	514,5	95,0	24	36,0	686,0	167,00	X	

Socket-Weld flenzen RF 150 lbs

volgens ASTM A 182/ANSI B 16.5

Socket-Weld flanges RF 150 lbs

acc. to ASTM A 182/ANSI B 16.5

Socket-Weld Flansche RF 150 lbs

nach ASTM A 182/ANSI B 16.5

Brides à emboîter RF 150 lbs

conformément à la norme ASTM A 182/ANSI B 16.5

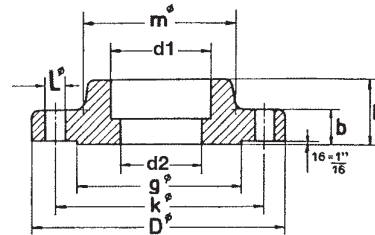

Omschrijving op pagina 83

Description on page 83

Umschreibung auf Seite 83

Description à la page 83

Buis diam. Pipe size Rohrdurchmesser Diam. Tube	Flens afmetingen in mm Flange dimensions in mm Flansch-Abmessungen in mm Dimensions en mm							bouten bolting Schrauben boulons			+/- Kg. St./pc.	304(L)	316(L)
	D	b	g	m	d1	d2	h	nr.	L	k			
	1/2" Sch 40 S STD	88,9	11,1	34,9	30,2	22,4	15,9	15,9	4	15,9			
1/2" Sch 80 S XS	88,9	11,1	34,9	30,2	22,4	15,9	15,9	4	15,9	60,3	0,40	X	X
3/4" Sch 40 S STD	98,4	12,7	42,9	38,1	27,7	20,8	15,9	4	15,9	69,8	0,70	X	X
3/4" Sch 80 S XS	98,4	12,7	42,9	38,1	27,7	20,8	15,9	4	15,9	69,8	0,70	X	X
1" Sch 10 S	107,9	14,3	50,8	49,2	34,5	26,7	17,5	4	15,9	79,4	0,90	X	X
1" Sch 40 S STD	107,9	14,3	50,8	49,2	34,5	26,7	17,5	4	15,9	79,4	0,90	X	X
1" Sch 80 S XS	107,9	14,3	50,8	49,2	34,5	26,7	17,5	4	15,9	79,4	0,90	X	X
1.1/2" Sch 40 S STD	127,0	17,5	73,0	65,1	49,5	40,9	22,2	4	15,9	98,4	1,50	X	X
1.1/2" Sch 80 S XS	127,0	17,5	73,0	65,1	49,5	40,9	22,2	4	15,9	98,4	1,50	X	X
2" Sch 40 S STD	152,4	19,1	92,1	77,8	62,0	52,6	25,4	4	19,0	120,6	2,30	X	X

Socket-Weld flenzen RF 300 lbs

volgens ASTM A 182/ANSI B 16.5

Socket-Weld flanges RF 300 lbs

acc. to ASTM A 182/ANSI B 16.5

Socket-Weld Flansche RF 300 lbs

nach ASTM A 182/ANSI B 16.5

Brides à emboîter RF 300 lbs

conformément à la norme ASTM A 182/ANSI B 16.5

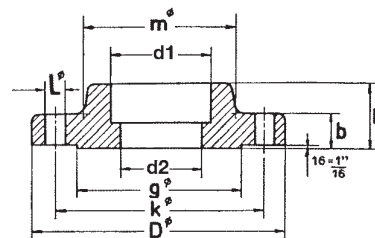

Buis diam. Pipe size Rohrdurchmesser Diam. Tube	Flens afmetingen in mm Flange dimensions in mm Flansch-Abmessungen in mm Dimensions en mm							bouten bolting Schrauben boulons			+/- Kg. St./pc.	304(L)	316(L)
	D	b	g	m	d1	d2	h	nr.	L	k			
	1/2" Sch 40 S STD	95,2	14,3	34,9	38,1	22,2	15,8	22,2	4	15,9			
1/2" Sch 80 S XS	95,2	14,3	34,9	38,1	22,2	15,8	22,2	4	15,9	66,7	0,70	X	X
3/4" Sch 40 S STD	117,5	15,9	42,9	47,6	27,8	20,8	25,4	4	19,1	82,5	1,20	X	X
3/4" Sch 80 S XS	117,5	15,9	42,9	47,6	27,8	20,8	25,4	4	19,1	82,5	1,20	X	X
1" Sch 40 S STD	123,8	17,5	50,8	54,0	34,5	26,7	26,9	4	19,1	88,9	1,40	X	X
1" Sch 80 S XS	123,8	17,5	50,8	54,0	34,5	26,7	26,9	4	19,1	88,9	1,40	X	X
1.1/2" Sch 40 S STD	155,6	20,6	73,0	69,8	49,6	40,9	30,2	4	22,5	114,3	2,80	X	X
1.1/2" Sch 80 S XS	155,6	20,6	73,0	69,8	49,6	40,9	30,2	4	22,5	114,3	2,80	X	X
2" Sch 40 S STD	165,1	22,2	92,1	84,1	62,0	52,6	33,3	8	19,1	127,0	3,30	X	X
2" Sch 80 S XS	165,1	22,2	92,1	84,1	62,0	52,6	33,3	8	19,1	127,0	3,30	X	X

**Naadloze
pijpnippels**

**Seamless
pipenipples**

**Nahtlose
Rohrnippels**

**Nipple hors tubes
sans soudure**

Naadloze pijpnippels Seamless pipenipples Nahtlose Rohrnippels Nipple hors tubes sans soudure

Spec. 001

Naadloze pijpnippels volgens ASME B1.20.1.

Met een fabrieksattest volgens EN 10204/3.1B.

Seamless pipenipples according to ASME B1.20.1.

Inspection certificate as per EN 10204/3.1B.

Nahtlose Rohrnippels nach ASME B1.20.1.

Abnahmeprüfzeugnis nach EN 10204/3.1B.

Nipple hors tubes sans soudure conformes à la norme ASME B1.20.1.

Certificat d'inspection selon la norme EN 10204/3.1B.

Pijpnippel TBE/PBE
Pipenipple TBE/PBE
Rohrnippel TBE/PBE
Nipple filetée TBE/PBE

NPT draadfittingen, omschrijving op pagina 96
 NPT threaded fittings, description on page 96
 NPT Gewinde Fittings, Umschreibung auf Seite 96
 Nipple filetée NPT, description à la page 96

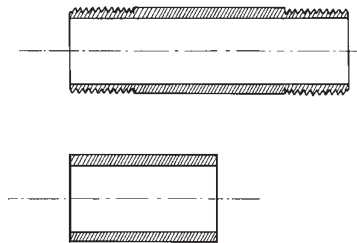

Pijpnippel

Pipenipple

Rohrnippel

Nipple filetée

Afmeting Size Abmessung Dimension		Lengte Length Länge Longueur	304(L)	316(L)	
1/4"	Sch80S XS	2"	X	X	
1/4"	Sch80S XS	3"	X	X	
3/8"	Sch80S XS	3"	X	X	
1/2"	Sch40S STD	4"	X	X	
1/2"	Sch80S XS	2"	X	X	
1/2"	Sch80S XS	3"	X	X	
1/2"	Sch80S XS	4"	X	X	
1/2"	Sch80S XS	6"		X	
3/4"	Sch80S XS	3"	X	X	
3/4"	Sch80S XS	4"	X	X	
1"	Sch80S XS	2"		X	
1"	Sch80S XS	3"	X	X	
1"	Sch80S XS	4"	X	X	
1"	Sch80S XS	6"	X	X	
1.1/2"	Sch80S XS	3"	X	X	
1.1/2"	Sch80S XS	4"	X	X	
1.1/2"	Sch80S XS	6"	X	X	
2"	Sch80S XS	4"	X	X	

Pijpnippel

Pipenipple

Rohrnippel

Nipple filetée

Pijpnippel TOE/BOE
Pipenipple TOE/BOE
Rohrnippel TOE/BOE
Nipple filetée TOE/BOE



NPT draadfittingen, omschrijving op pagina 96
NPT threaded fittings, description on page 96
NPT Gewinde Fittings, Umschreibung auf Seite 96
Nipple filetée NPT, description à la page 96

Afmeting Size Abmessung Dimension		Lengte Length Länge Longueur	304(L)	316(L)	
1/4"	Sch80S XS	1.1/2"		X	
1/4"	Sch80S XS	2"	X	X	
3/8"	Sch80S XS	1.1/2"	X	X	
3/8"	Sch80S XS	2"	X	X	
1/2"	Sch80S XS	2"	X	X	
1/2"	Sch80S XS	3"	X	X	
1/2"	Sch80S XS	4"	X	X	
3/4"	Sch80S XS	2"	X	X	
3/4"	Sch80S XS	3"	X	X	
3/4"	Sch80S XS	4"	X		
1"	Sch80S XS	2"	X	X	
1"	Sch80S XS	3"	X	X	
1"	Sch80S XS	4"	X		
1.1/2"	Sch80S XS	2"	X	X	
1.1/2"	Sch80S XS	4"	X		
2"	Sch80S XS	2"	X	X	
2"	Sch80S XS	3"	X	X	

Gesmede fittingen 3000 / 6000 lbs
Forged Fittings 3000 / 6000 lbs
Geschmiedene Fittings 3000 / 6000 lbs
Raccords forgés 3000 / 6000 lbs

Gesmede fittingen

Forged Fittings

Geschmiedene
Fittings

Raccords forgés

Spec. 001

Gesmede fittingen volgens ASTM A 182

Gesmede fittingen volgens ASTM A 182 , afmetingen volgens ASME B 16.11.

Voorzien van attest volgens EN 10204 / 3.1.B

Forged Fittings according to ASTM A 182

Forged Fittings according to ASTM A 182, dimensions to ASME B 16.11.

With mill certificate acc to EN 10204/ 3.1.B

Geschmiedene Fittings nach ASTM A 182

Geschmiedete Fittings nach ASTM A 182, Abmessungen nach ASME B 16.11.

Werksabnahme Zeugnis nach EN 10204 / 3.1.B

Raccords forgés conformes à la norme A 182

Raccords forgés conformes à la norme A 182. Dimensions conformes à la norme ASME B 16.11.

Avec certificat d'usine conforme à la norme EN 10204/3.1.B

Elbows

Elbows

Elbows

Elbows

Elbow 45° 3000 lbs

Omschrijving op pagina 99
Description on page 99
Umschreibung auf Seite 99
Description à la page 99

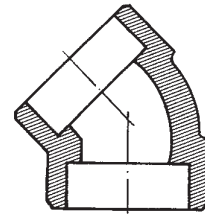

Afmeting Size Abmessung Dimension	D SW	L SW	304(L) SW	316(L) SW	316(L) NPT			
1/2"	33,0	22,0	X	X	X			
3/4"	38,0	25,0	X	X				
1"	46,0	28,5	X	X	X			
1.1/2"	62,0	35,0	X	X	X			
2"	76,0	43,0		X				

Elbow 90° 3000 lbs

Omschrijving op pagina 99
Description on page 99
Umschreibung auf Seite 99
Description à la page 99

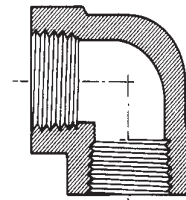
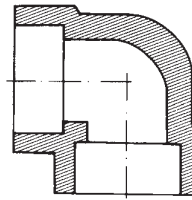

Afmeting Size Abmessung Dimension	D SW	L SW	304(L) SW	316(L) SW	D NPT	L NPT	304(L) NPT	316(L) NPT
1/4"	25,0	24,0	X	X	25,0	24,0	X	X
3/8"	25,0	24,0		X	33,0	28,0	X	X
1/2"	33,0	28,0	X	X	38,0	34,0	X	X
3/4"	38,0	34,0	X	X	46,0	38,0	X	X
1"	46,0	38,0	X	X	56,0	44,0	X	X
1.1/2"	62,0	50,0	X	X	76,0	60,0	X	X
2"	76,0	60,0	X	X	86,0	64,0	X	X

Unions F/F 3000 lbs

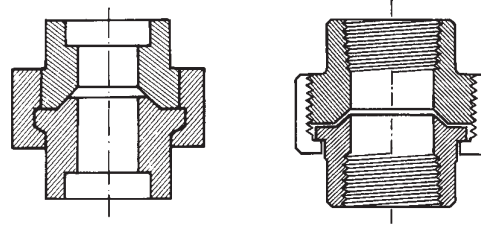

Omschrijving op pagina 99
Description on page 99
Umschreibung auf Seite 99
Description à la page 99

Union / Coupling

Union / Coupling

Union / Coupling

Union / Coupling

Afmeting Size Abmessung Dimension	D SW	L SW	304(L) SW	316(L) SW	D NPT	L NPT	304(L) NPT	316(L) NPT
3/8"	38,0	37,0			38,0	51,0	X	X
1/2"	48,0	38,0	X	X	48,0	54,0	X	X
3/4"	54,0	46,0	X	X	54,0	57,0	X	X
1"	63,0	53,0	X	X	63,0	64,0	X	X
1.1/4"	72,0	54,0			72,0	72,0		X
1.1/2"	77,0	56,0	X	X	77,0	80,0	X	X
2"	94,0	70,0	X		94,0	89,0	X	X

Full coupling 3000 lbs

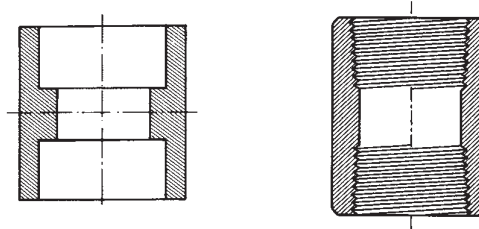

Omschrijving op pagina 99
Description on page 99
Umschreibung auf Seite 99
Description à la page 99

Afmeting Size Abmessung Dimension	D SW	L SW	304(L) SW	316(L) SW	D NPT	L NPT	304(L) NPT	316(L) NPT
1/4"	22,0	25,4			19,0	35,0	X	X
3/8"	26,0	25,4	X	X	22,2	38,0	X	X
1/2"	32,0	28,5	X	X	28,5	48,0	X	X
3/4"	36,0	34,9	X	X	35,0	51,0	X	X
1"	45,0	38,1	X	X	44,5	60,0	X	X
1.1/4"	55,0	38,1		X	57,5	66,5	X	X
1.1/2"	60,0	38,1	X	X	63,5	80,0	X	X
2"	75,0	50,6	X	X	77,0	86,0	X	X

Half coupling 3000 lbs

Omschrijving op pagina 99
Description on page 99
Umschreibung auf Seite 99
Description à la page 99

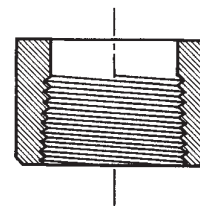
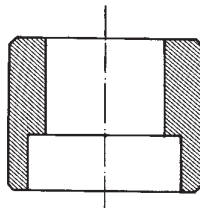

Afmeting Size Abmessung Dimension	D SW	L SW	304(L) SW	316(L) SW	D NPT	L NPT	304(L) NPT	316(L) NPT
1/4"	22,0	25,4			19,0	17,5	X	X
3/8"	26,0	26,9			22,2	19,0	X	X
1/2"	32,0	31,7	X	X	28,5	24,0	X	X
3/4"	36,0	36,5	X	X	35,0	25,5	X	X
1"	45,0	41,2	X	X	44,5	30,0	X	X
1.1/2"	60,0	44,4		X	63,5	40,0	X	X
2"	75,0	57,0			77,0	43,0	X	X

Reducing coupling 3000 lbs

Omschrijving op pagina 99
Description on page 99
Umschreibung auf Seite 99
Description à la page 99

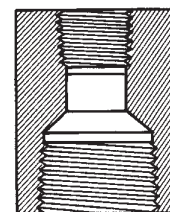
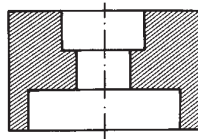

Afmeting Size Abmessung Dimension		D SW	L SW	304(L) SW	316(L) SW	D NPT	L NPT	304(L) NPT	316(L) NPT
1/2"	1/4"	32,0	28,5	X	X	28,5	48,0	X	X
1/2"	3/8"	32,0	28,5			28,5	48,0	X	X
3/4"	1/2"	36,0	34,9	X	X	35,0	51,0	X	X
1"	1/2"	45,0	38,1	X	X	44,5	60,0	X	X
1"	3/4"	45,0	38,1	X	X	44,5	60,0	X	X
1.1/2"	1"	60,0	38,1		X	63,5	80,0	X	X

Equal Tee 3000 lbs

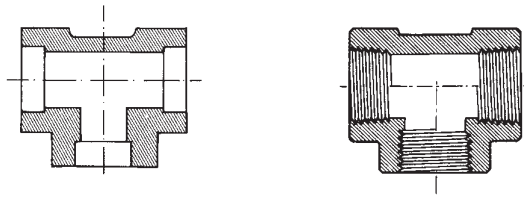

Omschrijving op pagina 99
Description on page 99
Umschreibung auf Seite 99
Description à la page 99

Tees

Tees

Tees

Tees

Afmeting Size Abmessung Dimension	D SW	L SW	304(L) SW	316(L) SW	D NPT	L NPT	304(L) NPT	316(L) NPT
1/4"	25,0	48,0	X		25,0	48,0	X	X
3/8"	25,0	48,0	X	X	33,0	56,0	X	X
1/2"	33,0	56,0	X	X	38,0	68,0	X	X
3/4"	38,0	68,0	X	X	46,0	76,0	X	X
1"	46,0	76,0	X	X	56,0	88,0	X	X
1.1/2"	62,0	100,0	X	X	76,0	120,0	X	X
2"	76,0	120,0	X	X	86,0	128,0	X	X

Reducing Tee 3000 lbs

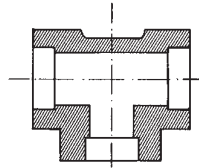

Omschrijving op pagina 99
Description on page 99
Umschreibung auf Seite 99
Description à la page 99

Afmeting Size Abmessung Dimension		D SW	L SW	304(L) SW	316(L) SW			
3/4"	1/2"	38,0	68,0	X	X			
1"	1/2"	46,0	76,0	X	X			
1"	3/4"	46,0	76,0	X	X			
1.1/2"	1/2"	62,0	100,0		X			
1.1/2"	3/4"	62,0	100,0	X	X			
1.1/2"	1"	62,0	100,0	X	X			

Cap / Nipple

Cap / Nipple

Cap / Nipple

Cap / Nipple

Round cap 3000 lbs

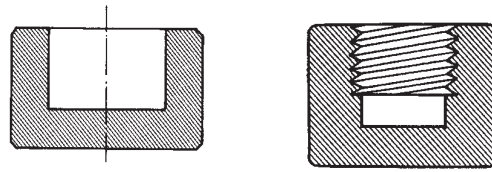

Omschrijving op pagina 99
 Description on page 99
 Umschreibung auf Seite 99
 Description à la page 99

Afmeting Size Abmessung Dimension	D SW	L SW	304(L) SW	316(L) SW	D NPT	L NPT	304(L) NPT	316(L) NPT
1/4"	22,0	15,0			19,0	26,0	X	X
1/2"	32,0			X	28,5	32,0	X	X
3/4"	36,0	23,0	X	X	35,0	36,0	X	X
1"	45,0	26,0	X	X	44,5	42,0	X	X
1.1/2"	60,0	30,0	X	X	63,5	45,0	X	X
2"	75,0	36,0			77,0	48,0	X	X

Hexagon nipple 3000 lbs

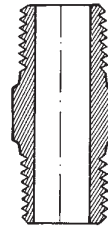

Omschrijving op pagina 99
 Description on page 99
 Umschreibung auf Seite 99
 Description à la page 99

Afmeting Size Abmessung Dimension	D NPT	L NPT	304(L) NPT	316(L) NPT
1/4"	16,0	39	X	X
3/8"	19,0	40	X	X
1/2"	22,0	46	X	X
3/4"	27,0	51	X	X
1"	35,0	57	X	X
1.1/2"	50,0	66	X	X
2"	63,0	70	X	X

Reducing Hexagon Nipple 3000 lbs

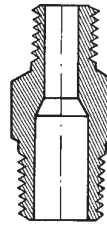

Omschrijving op pagina 99
Description on page 99
Umschreibung auf Seite 99
Description à la page 99

Nipple / Plug

Nipple / Plug

Nipple / Plug

Nipple / Plug

Afmeting Size Abmessung Dimension		D NPT	304(L) NPT	316(L) NPT				
1/2"	1/4"	22	X	X				
1/2"	3/8"	22		X				
3/4"	1/2"	27		X				
1"	1/2"	35		X				
1"	3/4"	35		X				

Hexagon Plug 6000 lbs

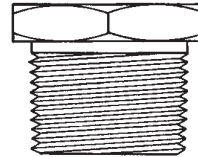

Omschrijving op pagina 99
Description on page 99
Umschreibung auf Seite 99
Description à la page 99

Afmeting Size Abmessung Dimension	D NPT	L NPT	304(L) NPT	316(L) NPT				
1/4"	16,0	23	X	X				
3/8"	19,0	24		X				
1/2"	22,0	28	X	X				
3/4"	27,0	31	X	X				
1"	35,0	34	X	X				
1.1/2"	50,0	41	X	X				
2"	63,0	44	X					

Bushing / Plug /
Sockolet

Bushing / Plug /
Sockolet

Bushing / Plug /
Sockolet

Bushing / Plug /
Sockolet

Hexagon bushing 6000 lbs

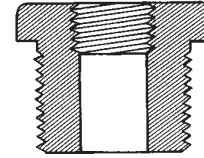

Omschrijving op pagina 99
Description on page 99
Umschreibung auf Seite 99
Description à la page 99

Afmeting Size Abmessung Dimension		D NPT	304(L) NPT	316(L) NPT				
3/8"	1/4"	19		X				
1/2"	1/4"	22		X				
1/2"	3/8"	22		X				
3/4"	1/2"	27	X	X				
1"	1/2"	35	X	X				
1"	3/4"	35	X	X				

Round Head Plug 6000 lbs

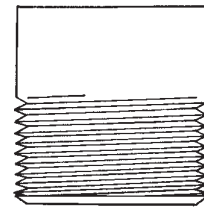

Omschrijving op pagina 99
Description on page 99
Umschreibung auf Seite 99
Description à la page 99

Afmeting Size Abmessung Dimension	D NPT	L NPT	304(L) NPT	316(L) NPT				
1/2"	21,4	45	X	X				
3/4"	27,0	45	X	X				
1"	33,3	51	X	X				

Sockolets 3000 lbs

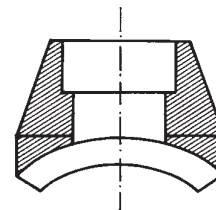

Omschrijving op pagina 99
Description on page 99
Umschreibung auf Seite 99
Description à la page 99

Size 1		runsize		304(L)	316(L)			
3/8"	2" t/m 4"	6" t/m 10"	12" t/m 24"	X				
1/2"	2" t/m 4"	6" t/m 10"	12" t/m 24"	X	X			
3/4"	2" t/m 4"	6" t/m 10"	12" t/m 24"	X	X			
1"	2" t/m 4"	6" t/m 10"	12" t/m 24"	X	X			
1.1/2"	2" t/m 4"	6" t/m 10"	12" t/m 24"	X	X			
2"	2" t/m 4"	6" t/m 10"	12" t/m 24"	X	X			

Draadfittings BSP

Threaded fittings BSP

Gewindefittings BSP

Raccords filetés BSP

Draadfittings

Threaded fittings

Gewindefittings

Raccords filetés

Spec. 001

BSP fittingen 150 lbs

Draadfittings, gegoten, gedraaid uit massief, of vervaardigd uit pijp met BSP-(gas) draad.
Werkdruk 150 lbs.

BSP fittings 150 lbs

Threaded fittings, cast, machined from bar or made from pipe with BSP (Withworth) thread.
Working pressure 150 lbs.

BSP Fittings 150 lbs

Gewinde Fittings, gegossen, hergestellt aus Rundstahl oder aus Rohr mit BSP (Gas)-Gewinde.
Betriebsdruck 150 lbs.

Raccords filetés BSP 150 livres

Raccords filetés, coulés, usinés à partir d'une barre ou d'un tube avec filetage BSP (GAZ).
Pression fonctionnelle : 150 livres.

Kogelafsluiter

volle doorlaat - 2 delig

Ball valves

full port - 2 piece body

Kugelhahn

mit vollem Durchgang - 2 teilig

Vanne à boule

Passage complet - 2 parties

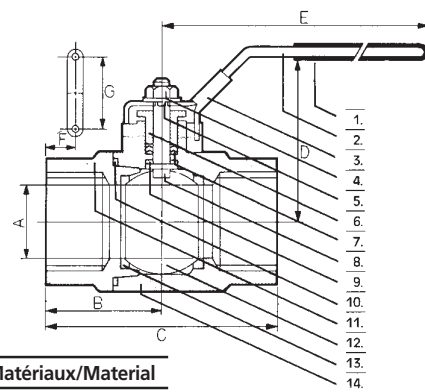

					Matériaux/Material	
1.	Beschermkapje	Plastic cover	Schutzkappe	Couvercle en plastique	Plastic	
2.	Hendel	Handle	Handhebel	Poignée	AISI 304	
3.	Afsluitmechanisme	Lock device	Anschlusssteil	Dispositif de verrouillage	AISI 304	
4.	Spindelmoer	Steam nut	Sechskantmutter	Ecrou broche	AISI 304	
5.	Spindelring	Steam washer	Unterlegscheibe	Rondelle broche	PTFE	
6.	Pakkingdrukker	Gland nut	Stopfbüchse	Ecrou à bride	AISI 304	
7.	Spindelpakking	Steam packing	Stopfbüchsenpackung	Etanchéité broche	PTFE	
8.	Spindel	Steam	Spindel	Broche	AISI 316	
9.	Dichtingsring	Thrust washer	Drucklagerdichtung	Rondelle de butée	PTFE + 15% GF	
10.	Verbindingspakking	Joint gasket	Gehäusedichtung	Joint d'étanchéité	PTFE + 15% GF	
11.	Inschroefwartel	Cap	Anschlusssteil	Obturateur	AISI 316	
12.	Kogel	Ball	Kugel	Bille	AISI 316	
13.	Zitting	Seat	Kugelsitzring	Siège	PTFE + 15% GF	
14.	Huis	Body	Gehäuse	Corps	AISI 316	

Omschrijving op pagina 107
Description on page 107
Umschreibung auf Seite 107
Description à la page 107

Afmeting - Dimensions - Abmessung - Dimensions

NW	Nom.	(mm/inch) A	(mm/inch) B	(mm/inch) C	(mm/inch) D	(mm/inch) E	(mm/inch) F	(mm/inch) G
8	1/4	11.6 0.457	30 1.181	60 2.362	45 1.772	110 4.331	12.7 0.50	28.45 1.120
10	3/8	12.7 0.50	30 1.181	60 2.362	45 1.772	110 4.331	12.7 0.50	28.45 1.120
15	1/2	15 0.591	32 1.260	64 2.520	45 1.772	130 5.118	12.7 0.50	28.45 1.120
20	3/4	20 0.787	38.5 1.516	77 3.032	50 1.969	130 5.118	22.10 0.87	34.80 1.370
25	1	25.4 1.00	45 1.772	90 3.543	65 2.559	155 6.102	22.10 0.87	34.80 1.370
32	1.1/4	32 1.260	50 1.967	100 3.937	70 2.756	155 6.102	23.62 0.93	38.1 1.50
40	1.1/2	38.1 1.50	59 2.323	118 4.646	75 2.953	185 7.283	23.62 0.93	38.1 1.50
50	2	50.8 2.00	68.5 2.697	137 5.398	85 3.346	185 7.283	23.62 0.93	38.1 1.50
65	2.1/2	65 2.561	82.5 3.248	165 6.496	136 5.354	250 9.843		70 2.756
80	3	80 3.152	97.5 3.839	195 7.677	149 5.866	250 9.843		70 2.756

Druk/Temp. tabel

Pressure/Temp. tabel

Druck/Temp. Tabelle

Tab. Pression & Temp.

Temp. °F -	°C	1000 PSI S.S. -	BAR
-50 to 250	10-120	1000	65
300	140,0	750	50
320	160,0	500	30
340	170,0	250	15
400 to Max.	200,0	100	5

Verloopnippel

Reducing nipple

Reduzier-Doppelnippel

Nippel réduit

BSP gasdraad fittingen, omschrijving op pagina 107
 BSP threaded fittings, description on page 107
 Whitworth Gewinde Fittings, Umschreibung auf Seite 107
 Raccords filetés BSP, description à la page 107

Draadfittingen

Threaded fittings

Gewindefittingen

Raccords filetés

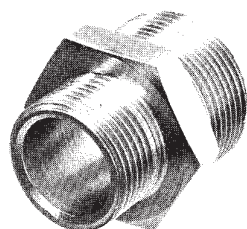
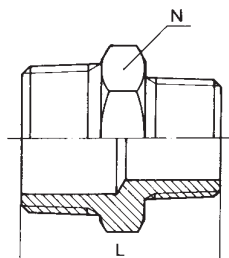

ND	NB	NW	DN	Afmeting Dimension Abmessung Dimension	L mm	N	316	
8	6			1/4"	1/8"	25	14	X
10	8			3/8"	1/4"	29	19	X
15	8			1/2"	1/4"	33	19	X
15	10			1/2"	3/8"	33	22	X
20	8			3/4"	1/4"	40	19	X
20	10			3/4"	3/8"	40	22	X
20	15			3/4"	1/2"	40	30	X
25	10			1"	3/8"	45	22	X
25	15			1"	1/2"	45	30	X
25	20			1"	3/4"	45	36	X
32	15			1.1/4"	1/2"	52	30	X
32	20			1.1/4"	3/4"	52	36	X
32	25			1.1/4"	1"	52	46	X
40	20			1.1/2"	3/4"	54	36	X
40	25			1.1/2"	1"	54	46	X
40	32			1.1/2"	1.1/4"	54	50	X
50	25			2"	1"	62	46	X
50	32			2"	1.1/4"	62	50	X
50	40			2"	1.1/2"	62	65	X
65	50			2.1/2"	2"	73	80	X

Deze BSP gasdraad fittingen zijn ook in gegoten uitvoering leverbaar. De afmetingen en inbouwmaten kunnen echter afwijken.

These BSP threaded fittings are also available in casted execution. However, dimensions may differ.

Die Whitworth Gewinde Fittings sind auch als Gussteile lieferbar. Die Abmessungen und Einbaumasse können jedoch abweichen.

Ces raccords filetés BSP sont également disponibles en fonte. Les dimensions peuvent toutefois varier.

Verloopsok

Reducing socket

Reduziermuffe

Manchon réduit

BSP gasdraad fittingen, omschrijving op pagina 107

BSP threaded fittings, description on page 107

Whitworth Gewinde Fittings, Umschreibung auf Seite 107

Raccords filetés BSP, description à la page 107

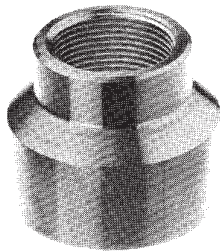
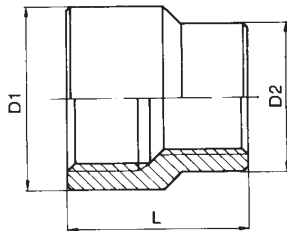

ND NB NW DN		Afmeting Dimension Abmessung Dimension		L mm	D1	D2	316
		D1	D2				
10	8	3/8"	1/4"	30	21,4	19,0	X
15	8	1/2"	1/4"	36	27,5	19,0	X
15	10	1/2"	3/8"	36	27,5	23,0	X
20	8	3/4"	1/4"	39	32,5	19,0	X
20	10	3/4"	3/8"	39	32,5	23,0	X
20	15	3/4"	1/2"	39	32,5	28,0	X
25	15	1"	1/2"	45	39,5	28,0	X
25	20	1"	3/4"	45	39,5	32,5	X
32	25	1.1/4"	1"	50	49,5	39,5	X
40	32	1.1/2"	1.1/4"	55	55,5	49,5	X
50	32	2"	1.1/4"	65	69,5	49,5	X
50	40	2"	1.1/2"	65	69,5	55,5	X
65	50	2.1/2"	2"	74	84,0	69,5	X
80	50	3"	2"	80	99,5	69,5	X

Deze BSP gasdraad fittingen zijn ook in gegoten uitvoering leverbaar. De afmetingen en inbouwmaten kunnen echter afwijken.

These BSP threaded fittings are also available in casted execution. However, dimensions may differ.

Die Whitworth Gewinde Fittings sind auch als Gussteile lieferbar. Die Abmessungen und Einbaumasse können jedoch abweichen.

Ces raccords filetés BSP sont également disponibles en fonte. Les dimensions peuvent toutefois varier.

Sok

Equal socket

Muffe

Manchon

BSP gasdraad fittingen, omschrijving op pagina 107

BSP threaded fittings, description on page 107

Whitworth Gewinde Fittings, Umschreibung auf Seite 107

Raccords filetés BSP, description à la page 107

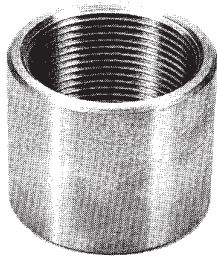
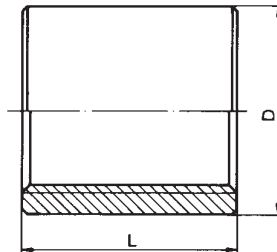

ND	Afmeting						
NB	Dimension						
NW	Abmessung	L	D				
DN	Dimension	mm	mm	316			
6	1/8"	17	14	X			
8	1/4"	25	18,50	X			
10	3/8"	26	21,30	X			
15	1/2"	34	26,50	X			
20	3/4"	36	32,50	X			
25	1"	43	39,50	X			
32	1.1/4"	48	48,30	X			
40	1.1/2"	48	55,50	X			
50	2"	56	68	X			
65	2.1/2"	65	82,50	X			
80	3"	71	95	X			
100	4"	83	125	X			

Lassok (halve)

Welding socket

Halbmuffe

Manchon à souder

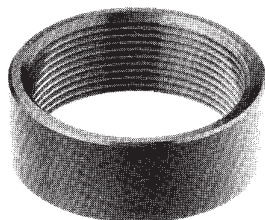
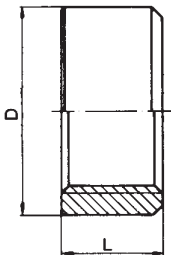

ND	Afmeting						
NB	Dimension						
NW	Abmessung	L	D				
DN	Dimension	mm	mm	316			
6	1/8"	8	14	X			
8	1/4"	11	18,50	X			
10	3/8"	12	21,30	X			
15	1/2"	15	26,50	X			
24	3/4"	17	32	X			
25	1"	20	39,50	X			
32	1.1/4"	22	48,30	X			
40	1.1/2"	22	55,50	X			
50	2"	26	68	X			
65	2.1/2"	30	82	X			
80	3"	33	95	X			
100	4"	39	125	X			

Lasnippel

Welding nipple

Anschweissnippel

Embout à souder

BSP gasdraad fittingen, omschrijving op pagina 107
 BSP threaded fittings, description on page 107
 Whitworth Gewinde Fittings, Umschreibung auf Seite 107
 Raccords filetés BSP, description à la page 107

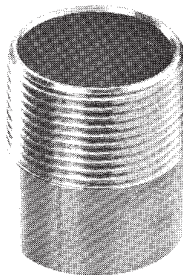
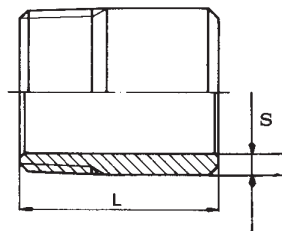

ND NB NW DN	Afmeting Dimension Abmessung Dimension	L mm	D mm	S mm	316		
6	1/8"	30	10,2	2,0	X		
8	1/4"	30	13,5	2,3	X		
10	3/8"	30	17,2	2,3	X		
15	1/2"	35	21,3	2,6	X		
20	3/4"	40	26,9	2,6	X		
25	1"	40	33,7	3,2	X		
32	1.1/4"	50	42,4	3,2	X		
40	1.1/2"	50	48,3	3,2	X		
50	2"	55	60,3	3,6	X		
65	2.1/2"	60	76,1	3,6	X		
80	3"	65	88,9	4,0	X		
100	4"	90	114,3	4,0	X		

Dubbele pijpnippel

Barrel nipple

Rohrdoppelnippel

Nipple

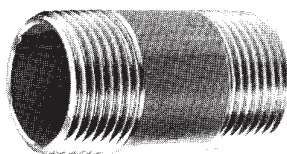
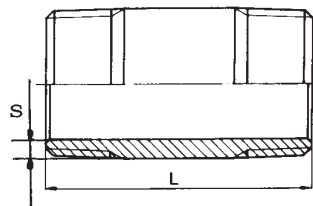

ND NB NW DN	Afmeting Dimension Abmessung Dimension	L mm	D mm	S mm	316		
6	1/8"	40	10,2	2,0	X		
8	1/4"	40	13,5	2,3	X		
10	3/8"	40	17,2	2,3	X		
15	1/2"	60	21,3	2,6	X		
20	3/4"	60	26,9	2,6	X		
25	1"	60	33,7	3,2	X		
32	1.1/4"	80	42,4	3,2	X		
40	1.1/2"	80	48,3	3,2	X		
50	2"	100	60,3	3,6	X		
65	2.1/2"	100	76,1	3,6	X		
80	3"	120	88,8	4,0	X		
100	4"	150	114,3	4,0	X		

Draadnippel

Parallel nipple

Rohrnippel

Nipple parallèle

BSP gasdraad fittingen, omschrijving op pagina 107
 BSP threaded fittings, description on page 107
 Whitworth Gewinde Fittings, Umschreibung auf Seite 107
 Raccords filetés BSP, description à la page 107

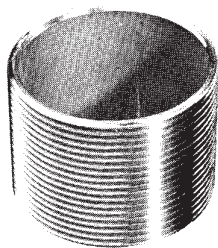
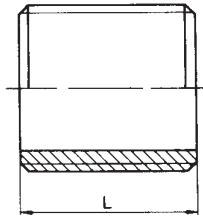

ND	Afmeting						
NB	Dimension						
NW	Abmessung	L					
DN	Dimension	mm	316				
10	3/8"	22	X				
15	1/2"	25	X				
20	3/4"	30	X				
25	1"	35	X				
40	1.1/2"	38	X				
50	2"	45	X				
65	2.1/2"	55	X				
80	3"	60	X				

Dubbele zeskantnippel

Hexagon nipple

6-kt Doppelnippel

Nipple hexagonal double

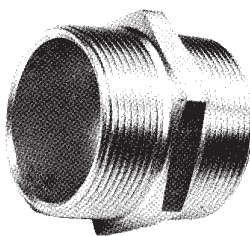
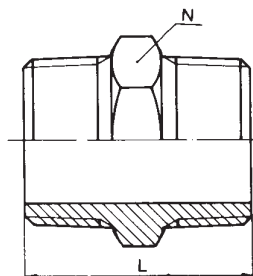

ND	Afmeting						
NB	Dimension						
NW	Abmessung	L					
DN	Dimension	mm	N	316			
6	1/8"	21	12	X			
8	1/4"	28	14	X			
10	3/8"	29	19	X			
15	1/2"	36	22	X			
20	3/4"	41	30	X			
25	1"	46	35	X			
32	1.1/4"	54	46	X			
40	1.1/2"	54	50	X			
50	2"	65	65	X			
65	2.1/2"	76	80	X			
80	3"	85	90	X			

Deze BSP gasdraad fittingen zijn ook in gegoten uitvoering leverbaar. De afmetingen en inbouwmaten kunnen echter afwijken.

These BSP threaded fittings are also available in casted execution. However, dimensions may differ.

Die Whitworth Gewinde Fittings sind auch als Gussteile lieferbar. Die Abmessungen und Einbaumasse können jedoch abweichen.

Ces raccords filetés BSP sont également disponibles en fonte. Les dimensions peuvent toutefois varier.

Knie 90° BI/BI**Elbow 90° F/F****Winkel 90° F/F****Coude 90° F/F**

BSP gasdraad fittingen, omschrijving op pagina 107

BSP threaded fittings, description on page 107

Whitworth Gewinde Fittings, Umschreibung auf Seite 107

Raccords filetés BSP, description à la page 107

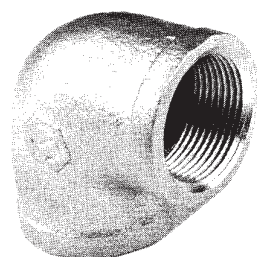
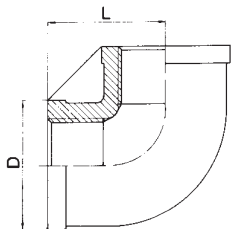

ND	Afmeting						
NB	Dimension						
NW	Abmessung	L					
DN	Dimension	mm	316				
6	1/8"	19	X				
8	1/4"	21	X				
10	3/8"	25	X				
15	1/2"	28	X				
20	3/4"	33	X				
25	1"	38	X				
32	1.1/4"	45	X				
40	1.1/2"	50	X				
50	2"	58	X				
65	2.1/2"	75	X				
80	3"	85	X				

Deze BSP gasdraad fittingen zijn alleen in gegoten uitvoering leverbaar.

These BSP threaded fittings are only available in casted execution.

Die Whitworth Gewinde Fittings sind nur als Gussteile lieferbar.

Ces raccords filetés BSP sont uniquement disponibles en fonte.

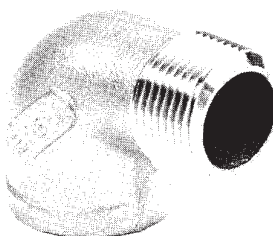
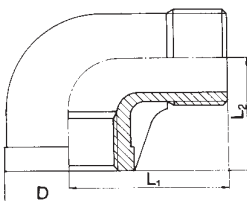
Knie BI/BU**Street elbow M/F****Winkel I.A Gewinde M/F****Coude M/F**

ND	Afmeting						
NB	Dimension						
NW	Abmessung	L1	L2	D			
DN	Dimension	mm	mm	mm	316		
8	1/4"	30	21	20	X		
10	3/8"	37	24	24	X		
15	1/2"	41	29	29	X		
20	3/4"	48	33	35	X		
25	1"	54	38	44	X		
32	1.1/4"	62	44	53	X		
40	1.1/2"	68	49	60	X		
50	2"	83	57	73	X		

Deze BSP gasdraad fittingen zijn alleen in gegoten uitvoering leverbaar.

These BSP threaded fittings are only available in casted execution.

Die Whitworth Gewinde Fittings sind nur als Gussteile lieferbar.

Ces raccords filetés BSP sont uniquement disponibles en fonte.

T-stuk
T-piece
T-stück
Te

BSP gasdraad fittingen, omschrijving op pagina 107
 BSP threaded fittings, description on page 107
 Whitworth Gewinde Fittings, Umschreibung auf Seite 107
 Raccords filetés BSP, description à la page 107

Draadfittingen

Threaded fittings

Gewindefittingen

Raccords filetés

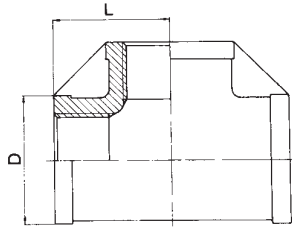

ND	Afmeting						
NB	Dimension						
NW	Abmessung	L					
DN	Dimension	mm	316				
8	1/4"	21	X				
10	3/8"	24	X				
15	1/2"	28	X				
20	3/4"	33	X				
25	1"	38	X				
32	1.1/4"	45	X				
40	1.1/2"	49	X				
50	2"	57	X				

Deze BSP gasdraad fittingen zijn alleen in gegoten uitvoering leverbaar.
 These BSP threaded fittings are only available in casted execution.
 Die Whitworth Gewinde Fittings sind nur als Gussteile lieferbar.
 Ces raccords filetés BSP sont uniquement disponibles en fonte.

Koppeling BI/BI konische raakvlakken
Union F/F thread taper faces
Verschraubung kon. dichtend
Raccord F/F à siège conique

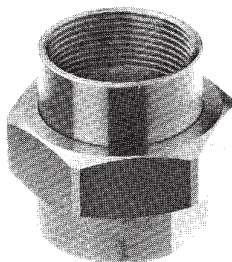
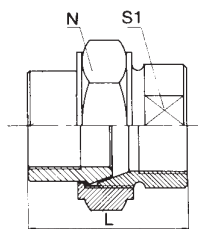

ND	Afmeting						
NB	Dimension						
NW	Abmessung	L					
DN	Dimension	mm	N	S1	316		
8	1/4"	38	27	21	X		
10	3/8"	41	32	24	X		
15	1/2"	46	36	26	X		
20	3/4"	50	46	32	X		
25	1"	55	50	41	X		
32	1.1/4"	62	60	48	X		
40	1.1/2"	64	65	53	X		
50	2"	67	83	70	X		
80	3"	75	115	100	X		

Deze BSP gasdraad fittingen zijn ook in gegoten uitvoering leverbaar. De afmetingen en inbouwmaten kunnen echter afwijken.
 These BSP threaded fittings are also available in casted execution. However, dimensions may differ.
 Die Whitworth Gewinde Fittings sind auch als Gussteile lieferbar. Die Abmessungen und Einbaumasse können jedoch abweichen.
 Ces raccords filetés BSP sont également disponibles en fonte. Les dimensions peuvent toutefois varier.

Koppeling BI/BU konische raakvlakken
Union M/F thread taper faces
Verschraubung I-A Gewinde kon. dichtend
Raccord M/F à siège conique

BSP gasdraad fittingen, omschrijving op pagina 107
 BSP threaded fittings, description on page 107
 Whitworth Gewinde Fittings, Umschreibung auf Seite 107
 Raccords filetés BSP, description à la page 107

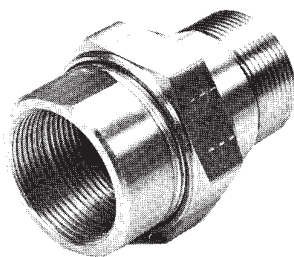
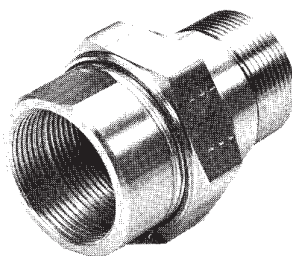

ND	Afmeting						
NB	Dimension						
NW	Abmessung	L					
DN	Dimension	mm	N	S1	S2	316	
8	1/4"	46	27	21	15	X	
10	3/8"	53	32	24	19	X	
15	1/2"	61	36	26	22	X	
20	3/4"	66	46	32	28	X	
25	1"	75	50	41	35	X	
32	1.1/4"	81	60	48	43	X	
40	1.1/2"	84	65	53	49	X	
50	2"	87	83	70	60	X	
65	2.1/2"	97	100	85	76	X	

Deze BSP gasdraad fittingen zijn ook in gegoten uitvoering leverbaar. De afmetingen en inbouwmaten kunnen echter afwijken.

These BSP threaded fittings are also available in casted execution. However, dimensions may differ.

Die Whitworth Gewinde Fittings sind auch als Gussteile lieferbar. Die Abmessungen und Einbaumasse können jedoch abweichen.

Ces raccords filetés BSP sont également disponibles en fonte. Les dimensions peuvent toutefois varier.

Laskoppeling konische raakvlakken
Union, buttweld ends, taper faces
Verschraubung mit Schweissenden kon.dichtend
Raccord à souder à siège conique

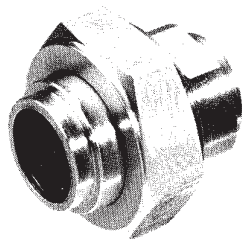
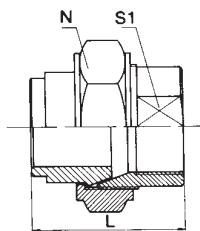

ND	Afmeting						
NB	Dimension						
NW	Abmessung	L					
DN	Dimension	mm	N	S1	316		
10	3/8"	40	32	21	X		
15	1/2"	40	36	23	X		
20	3/4"	44	46	30	X		
25	1"	52	50	38	X		
32	1.1/4"	57	60	45	X		
40	1.1/2"	63	65	50	X		
50	2"	72	83	66	X		
65	2.1/2"	80	100	82	X		

Deze BSP gasdraad fittingen zijn ook in gegoten uitvoering leverbaar. De afmetingen en inbouwmaten kunnen echter afwijken.

These BSP threaded fittings are also available in casted execution. However, dimensions may differ.

Die Whitworth Gewinde Fittings sind auch als Gussteile lieferbar. Die Abmessungen und Einbaumasse können jedoch abweichen.

Ces raccords filetés BSP sont également disponibles en fonte. Les dimensions peuvent toutefois varier.

Ronde dop

Round cap

Rundkappe

Bouchon femelle rond

BSP gasdraad fittingen, omschrijving op pagina 107
 BSP threaded fittings, description on page 107
 Whitworth Gewinde Fittings, Umschreibung auf Seite 107
 Raccords filetés BSP, description à la page 107

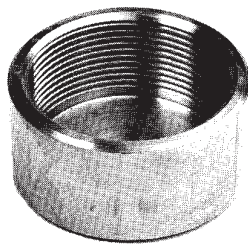
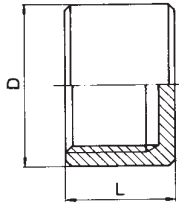

ND	Afmeting						
NB	Dimension						
NW	Abmessung	L	D				
DN	Dimension	mm	mm	316			
8	1/4"	17	18	X			
10	3/8"	18	23	X			
15	1/2"	22	28	X			
20	3/4"	24	35	X			
25	1"	28	40	X			
32	1.1/4"	31	50	X			
40	1.1/2"	31	60	X			
50	2"	37	70	X			
80	3"	46	100	X			

Deze BSP gasdraad fittingen zijn ook in gegoten uitvoering leverbaar. De afmetingen en inbouwmaten kunnen echter afwijken.

These BSP threaded fittings are also available in casted execution. However, dimensions may differ.

Die Whitworth Gewinde Fittings sind auch als Gussteile lieferbar. Die Abmessungen und Einbaumasse können jedoch abweichen.

Ces raccords filetés BSP sont également disponibles en fonte. Les dimensions peuvent toutefois varier.

Zeskant kap

Hexagon cap

6 kt Kappe

Bouchon femelle hexagonal

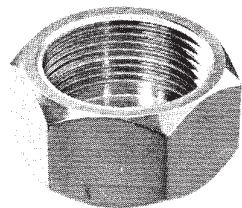
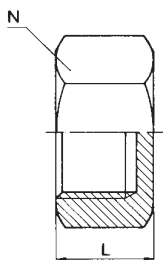

ND	Afmeting						
NB	Dimension						
NW	Abmessung	L	N				
DN	Dimension	mm	mm	316			
6	1/8"	13	14	X			
8	1/4"	17	19	X			
10	3/8"	18	22	X			
15	1/2"	22	27	X			
20	3/4"	24	32	X			
25	1"	28	40	X			
32	1.1/4"	30	50	X			
40	1.1/2"	31	55	X			
50	2"	35	70	X			
65	2.1/2"	40	85	X			
80	3"	45	95	X			
100	4"	54	136	X			

Deze BSP gasdraad fittingen zijn ook in gegoten uitvoering leverbaar. De afmetingen en inbouwmaten kunnen echter afwijken.

These BSP threaded fittings are also available in casted execution. However, dimensions may differ.

Die Whitworth Gewinde Fittings sind auch als Gussteile lieferbar. Die Abmessungen und Einbaumasse können jedoch abweichen.

Ces raccords filetés BSP sont également disponibles en fonte. Les dimensions peuvent toutefois varier.

Zeskant plug cil. draad
Hexagon plug with parallel thread
6 kt Stopfen zylindrisch dichtend
Bouchon mâle hexagonal à filetage parallèle

BSP gasdraad fittingen, omschrijving op pagina 107
 BSP threaded fittings, description on page 107
 Whitworth Gewinde Fittings, Umschreibung auf Seite 107
 Raccords filetés BSP, description à la page 107

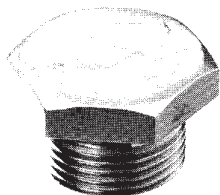
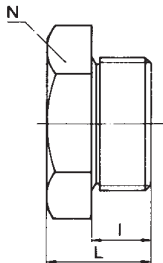

ND	Afmeting					
NB	Dimension					
NW	Abmessung	L	N	l	316	
DN	Dimension	mm		mm		
8	1/4"	16	19	10	X	
10	3/8"	17	22	11	X	
15	1/2"	22	27	14	X	
20	3/4"	24	32	15	X	
25	1"	28	41	18	X	
40	1.1/2"	32	55	20	X	
50	2"	36	70	24	X	

Zeskant plug kon. draad
Hexagon plug with taper thread
6 kt Stopfen konisch dichtend
Bouchon mâle hexagonal à filetage conique

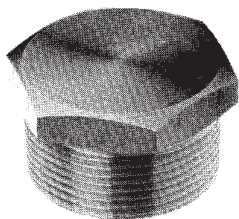
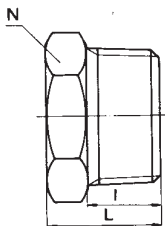

ND	Afmeting					
NB	Dimension					
NW	Abmessung	L	N	l	316	
DN	Dimension	mm	mm	mm		
6	1/8"	14	14	8	X	
8	1/4"	17	14	11	X	
10	3/8"	17	19	11	X	
15	1/2"	22	22	15	X	
20	3/4"	24	30	16	X	
25	1"	27	36	18	X	
32	1.1/4"	32	46	21,5	X	
40	1.1/2"	33	50	21,5	X	
50	2"	38	65	25,5	X	

Deze BSP gasdraad fittingen zijn ook in gegoten uitvoering leverbaar. De afmetingen en inbouwmaten kunnen echter afwijken.

These BSP threaded fittings are also available in casted execution. However, dimensions may differ.

Die Whitworth Gewinde Fittings sind auch als Gussteile lieferbar. Die Abmessungen und Einbaumasse können jedoch abweichen.

Ces raccords filetés BSP sont également disponibles en fonte. Les dimensions peuvent toutefois varier.

Vierkant plug kon. draad
Square head plug taper thread
4-kt Stopfen konisch dichtend
Bouchon carré à filetage conique

BSP gasdraad fittingen, omschrijving op pagina 107
 BSP threaded fittings, description on page 107
 Whitworth Gewinde Fittings, Umschreibung auf Seite 107
 Raccords filetés BSP, description à la page 107

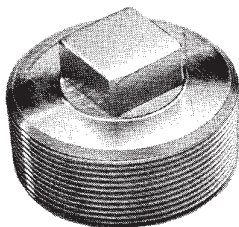
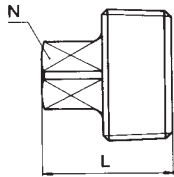

ND	Afmeting						
NB	Dimension						
NW	Abmessung	L	N				
DN	Dimension	mm	mm	316			
8	1/4"	18	9	X			
10	3/8"	20	10	X			
15	1/2"	22	11	X			
20	3/4"	27	16	X			
25	1"	32	19	X			
40	1.1/2"	37	22	X			

6-kt Gasmoer
Hexagon lock nut
6-kt Mutter
Contre-écrou hexagonal

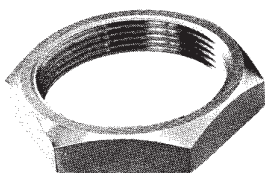

ND	Afmeting						
NB	Dimension						
NW	Abmessung	L	N				
DN	Dimension	mm	mm	316			
8	1/4"	8	22	X			
10	3/8"	9	27	X			
15	1/2"	9	32	X			
20	3/4"	10	36	X			
25	1"	11	46	X			
40	1.1/2"	13	60	X			
50	2"	14	75	X			

Verloopring Hexagon Bushing Absatzstucke Bague à tête hexagonale

BSP gasdraad fittingen, omschrijving op pagina 107

BSP threaded fittings, description on page 107

Whitworth Gewinde Fittings, Umschreibung auf Seite 107

Raccords filetés BSP, description à la page 107

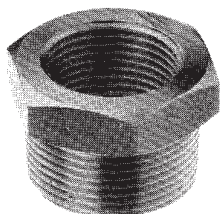
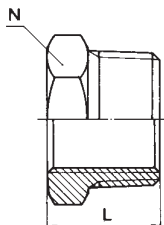

ND NB NW DN		Afmeting Dimension Abmessung Dimension		L mm	N	316	
8	6	1/4"	1/8"	17	14	X	
10	6	3/8"	1/8"	18	14	X	
10	8	3/8"	1/4"	18	19	X	
15	8	1/2"	1/4"	21	19	X	
15	10	1/2"	3/8"	21	22	X	
20	10	3/4"	3/8"	25	22	X	
20	15	3/4"	1/2"	25	30	X	
25	8	1"	1/4"	27	19	X	
25	10	1"	3/8"	27	22	X	
25	15	1"	1/2"	27	30	X	
25	20	1"	3/4"	27	35	X	
32	15	1.1/4"	1/2"	33	30	X	
32	20	1.1/4"	3/4"	33	35	X	
32	25	1.1/4"	1"	33	46	X	
40	15	1.1/2"	1/2"	32	30	X	
40	20	1.1/2"	3/4"	32	35	X	
40	25	1.1/2"	1"	32	46	X	
40	32	1.1/2"	1.1/4"	32	50	X	
50	15	2"	1/2"	38	30	X	
50	20	2"	3/4"	38	35	X	
50	25	2"	1"	38	46	X	
50	32	2"	1.1/4"	38	50	X	
50	40	2"	1.1/2"	38	65	X	
65	40	2.1/2"	1.1/2"	46	65	X	
65	50	2.1/2"	2"	46	80	X	
80	50	3"	2"	51	80	X	
80	65	3"	2.1/2"	51	90	X	

Deze BSP gasdraad fittingen zijn ook in gegoten uitvoering leverbaar.

These BSP threaded fittings are also available in casted execution.

Die Whitworth Gewinde Fittings sind auch als Gussteile lieferbar.

Ces raccords filetés BSP sont également disponibles en fonte.

Draadbocht 90° - zonder sok
Bend 90° - without equal socket
Bogen 90° - ohne Muffe
Coude 90° - sans manchon

BSP gasdraad fittingen, omschrijving op pagina 107
 BSP threaded fittings, description on page 107
 Whitworth Gewinde Fittings, Umschreibung auf Seite 107
 Raccords filetés BSP, description à la page 107

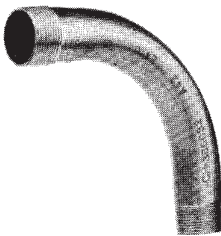
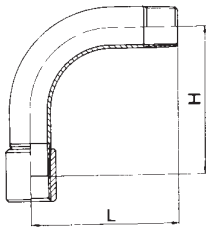

ND	Afmeting							
NB	Dimension							
NW	Abmessung	L	H					
DN	Dimension	mm	mm	1.4571				
8	1/4"	60	60	X				
10	3/8"	70	70	X				
15	1/2"	80	80	X				
20	3/4"	100	100	X				
25	1"	120	120	X				
32	1.1/4"	140	140	X				
40	1.1/2"	160	160	X				
50	2"	190	190	X				

Slangpilaar
Hose nipple
Schlauchtüllen
Raccord de flexible

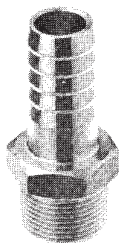
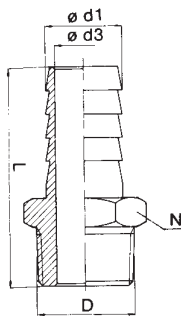

ND	Afmeting						
NB	Dimension						
NW	Abmessung	L	N	d1	d3		
DN	Dimension	mm		mm	mm	316	
6	1/8"	36	14	6,5	3,5	X	
8	1/4"	40	14	6,5	3,5	X	
8	1/4"	40	14	8,5	4,5	X	
10	3/8"	42	19	11,0	7,0	X	
14	1/2"	48	22	14,0	10,0	X	
17	1/2"	48	22	17,0	13,0	X	
20	3/4"	56	30	21,0	16,0	X	
25	1"	65	36	26,5	21,0	X	
32	1.1/4"	75	46	33,0	25,0	X	
40	1.1/2"	78	50	41,0	32,0	X	
50	2"	96	65	52,0	42,0	X	

Deze BSP gasdraad fittingen zijn ook in gegoten uitvoering leverbaar. De afmetingen en inbouwmaten kunnen echter afwijken.

These BSP threaded fittings are also available in casted execution. However, dimensions may differ. Die Whitworth Gewinde Fittings sind auch als Gussteile lieferbar. Die Abmessungen und Einbaumasse können jedoch abweichen.

Ces raccords filetés BSP sont également disponibles en fonte. Les dimensions peuvent toutefois varier.

**Snijring-
koppelingen**

Bite ringcouplings

**Schneidring-
verschraubungen**

**Accessoires à
bague coupante**

Snijringkoppelingen

Bite ringcouplings

Schneidringverschraubungen

Accessoires à bague coupante

Spec. 001

Snijringkoppelingen

Snijringkoppelingen volgens DIN 2353.

Bite ring couplings

Bite ring couplings according to DIN 2353.

Schneidringverschraubungen

Schneidringverschraubungen nach DIN 2353.

Accessoires à bague coupante

Accessoires à bague coupante conformes à la norme DIN 2353.

Deze BSP gasdraad fittingen zijn ook in gegoten uitvoering leverbaar. De afmetingen en inbouwmaten kunnen echter afwijken.

These BSP threaded fittings are also available in casted execution. However, dimensions may differ.

Die Whitworth Gewinde Fittings sind auch als Gussteile lieferbar. Die Abmessungen und Einbaumasse können jedoch abweichen.

Ces raccords filetés BSP sont également disponibles en fonte. Les dimensions peuvent toutefois varier.

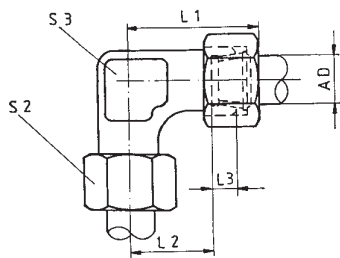

Kniekoppeling
Equal elbow couplings
Winkel-Verschraubungen
Raccords coudés

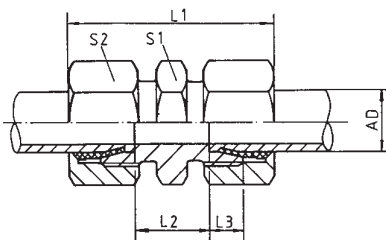

Tussenkoppeling
Straight couplings
Gerade Verschraubungen
Raccords intermédiaires

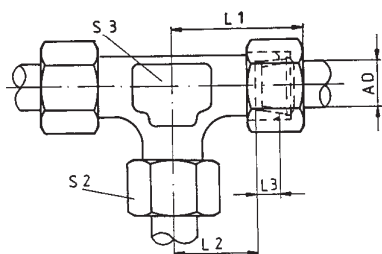

Tee-koppeling
Equal tee couplings
T-Verschraubungen
Raccord en T

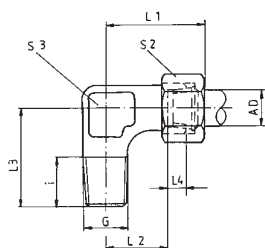

Knie inschroefkoppeling
Male stud elbows
Winkel-Einschraubverschraubungen
Raccords mâles coudés

Deze fittingen zijn leverbaar in maten van 6 tot 30 mm. Tevens beschikken wij over bijbehorende snijringen en wartelmoeren.

These fittings are available in sizes from 6 to 30mm. We also stock cutting rings and nuts.

Diese Fittings sind lieferbar in Abmessungen von 6 bis 30 mm. Zusätzlich haben wir auch Schneidringe und Muttern im Lieferprogramm.

Ces raccords sont disponibles en dimensions de 6 à 30 mm. Nous proposons également les écrous et bagues complémentaires.

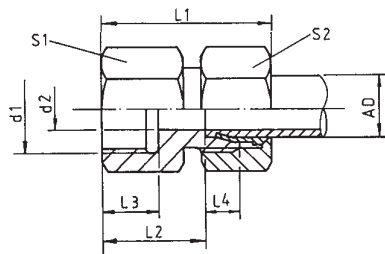

Rechte opschroefkoppeling
Parallel female stud couplings
Gerade Aufschraubverschraubungen
Raccords droits à visser

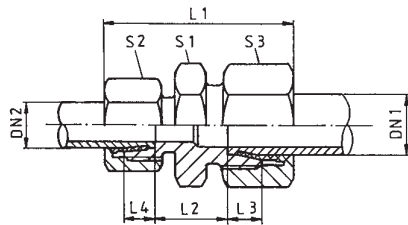

Rechte verloopkoppelingen
Reducing unions
Gerade Reduzierschraubungen
Raccords réducteurs droits

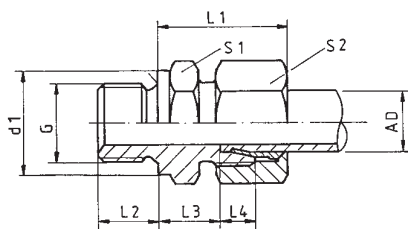

Rechte inschroefkoppeling, licht
Male stud couplings, light
Gerade Einschraubverschraubungen, leicht
Raccords mâles droits, légers

Technische bijlagen
Technical Data
Technischen Daten
Données techniques

Technische bijlagen

Technical Data

Technischen Daten

Données techniques

ASTM/ASME/MSS/DIN/NFA normen**ASTM (American Society for Testing and Materials)****ASME (American Society of Mechanical Engineers)**

ASTM/ASME	A	182	Roestvaststaal gesmede fittingen, flenzen en afsluiters.
ASTM/ASME	A	213	Naadloze roestvaststaal buizen voor o.a. warmtewisselaars en verdamperen.
ASTM/ASME	A	249	Gelaste buizen, gelast zonder toevoegmateriaal voor o.a. condensoren en warmtewisselaars.
ASTM/ASME	A	269	Naadloze en gelaste roestvaststaal buizen voor algemene toepassing met nauwe toleranties.
ASTM/ASME	A	312	Naadloze en gelaste buizen (gelaste buizen zonder toevoegmateriaal) voor algemene toepassing.
ASTM/ASME	A	358	Gelaste buizen met lastoevoegmateriaal. Klasse 1 tweezijdig gelast en 100% radiografisch onderzoek. Klasse 2 tweezijdig gelast zonder radiografisch onderzoek. Klasse 3 eenzijdig gelast en 100% radiografisch onderzoek. Klasse 4 eenzijdig gelast, de las aan de binnenkant van de buis zonder toevoegmateriaal en 100% radiografisch onderzoek. Klasse 5 tweezijdig gelast en plaatselijk radiografisch onderzoek.
ASTM/ASME	A	403	Roestvaststaal lasfittingen.
ASTM/ASME	A	409	Gelaste austenitische buizen (grote diameter) voor corrosief of hoog temperatuur gebruik.
ASTM/ASME	A	450	Algemene norm voor koolstofstaal, ferritische en austenitische roestvaststalen buis.
ASTM/ASME	A	451	Norm voor roestvaststaal centrifugaal gegoten buis.
ASTM/ASME	A	473	Roestvaststalen en hittebestendige smeedstukken.

ANSI (American National Standards Institute)

ASME	B	16.5	Roestvaststaal flenzen volgens ASTM.
ASME	B	16.9	Roestvaststaal fittingen volgens ASTM.
ASME	B	16.11	Gesmede las- en draadfittingen volgens ASTM.
ASME	B	16.25	Vorm van laseinden.

MSS (Manufacturers Standardization Society)

MSS	SP	6	Pakkingvlakken van flenzen.
MSS	SP	25	Merksysteem voor ASTM fittingen, flenzen en koppelingen.
MSS	SP	43	ASTM lasfittingen.

DIN (Deutsche Industrie Norm)

DIN	17458	Naadloze ronde austenitische roestvaststalen buizen voor speciale toepassingen
DIN	2353	Pijpschroefverbinding
DIN	2462	Toleranties voor roestvaststaal naadloze buis
DIN	2605	Lasbochten
DIN	2606	Lasbochten
DIN	2615	Las T-stukken
DIN	2616	Las verloopstukken
DIN	2617	Laskappen

ISO (International Organization for Standardization)

ISO	1127	Afmetingen, toleranties en gewichten van roestvaststalen buizen.
-----	------	--

EN (Europese Normen)

EN	10088-1	Lijst van corrosievaste staalsoorten
EN	10204	Soorten keuringsdocumenten
EN	10296 -2	Gelaste ronde roestvaststalen buizen voor algemene toepassingen
EN	10297-2	Naadloze ronde roestvaststalen buizen voor algemene toepassingen
EN	10217-7	Gelaste ronde austenitische roestvaststalen buizen voor speciale toepassingen
EN	ISO 1127	Toleranties voor roestvaststaal gelaste buis
EN	EN 1092-1 type 5 PN 6-100	Blindflenzen PN 6-100
EN	EN 1092-1 type 1 PN 10	Vlakke aanlasflenzen PN 10
EN	EN 1092-1 type 11 PN 10	Voorlasflenzen PN 10
EN	EN 1092-1 type 11 PN 16	Voorlasflenzen PN 16
EN	EN 1092-1 type 11 PN 25	Voorlasflenzen PN 25
EN	EN 1092-1 type 11 PN 40	Voorlasflenzen PN 40
EN	EN 1092-1 PN 64	Voorlasflenzen PN 64
EN	EN 1092-1 PN 10	Boordringen en flenzen PN 10

NFA (Franse Normen)

NFA	49117	Naadloze buizen.
NFA	49147	Langsnaad gelaste buizen.
NFA	29203	Flenzen en kragen in staal en roestvaststaal.

ASTM/ASME/MSS/DIN/NFA standards**ASTM (American Society for Testing and Materials)****ASME (American Society of Mechanical Engineers)**

ASTM/ASME	A	182	Stainless steel forged fittings, flanges and valves.
ASTM/ASME	A	213	Seamless stainless steel tubes for, among other things, heat exchangers and evaporators.
ASTM/ASME	A	249	Welded tubes, welded without filler material for, among other things, condensers and heat exchangers.
ASTM/ASME	A	269	Seamless and welded stainless steel tubes for general applications involving tight tolerances.
ASTM/ASME	A	312	Seamless and welded tubes (welded tubes without filler material) for general applications.
ASTM/ASME	A	358	Welded tubes with filler material. Class 1 double vee welded and 100% X-ray tested. Class 2 double vee welded without X-ray testing. Class 3 vee welded and 100% X-ray tested. Class 4 vee welded, the weld on the inside of the tube. without filler material and 100% X-ray tested. Class 5 double vee welded and X-ray tested locally.
ASTM/ASME	A	403	Stainless steel fittings.
ASTM/ASME	A	409	Welded austenitic tubes (large diameter) for corrosive or high temperature service.
ASTM/ASME	A	450	General standard for carbon, ferritic and austenitic alloyed steel tube.
ASTM/ASME	A	451	Standard for stainless steel centrifugally cast tube.
ASTM/ASME	A	473	Stainless steel and heat resistant forgings.

ANSI (American National Standards Institute)

ASME	B	16.5	Stainless steel flanges as per ASTM.
ASME	B	16.9	Stainless steel fittings as per ASTM.
ASME	B	16.11	Forged fittings with and without threads as per ASTM.
ASME	B	16.25	Form of welding studs.

MSS (Manufacturers Standardization Society)

MSS	SP	6	Packing faces of flanges.
MSS	SP	25	Marking system for ASTM fittings, flanges and couplings.
MSS	SP	43	ASTM fittings.

DIN (Deutsche Industrie Norm)

DIN	17458	Seamless round austenitic stainless steel tubes for special applications
DIN	2353	Pipe thread connector with cutting ring
DIN	2462	Tolerances for stainless steel seamless tube
DIN	2605	Elbows
DIN	2606	Elbows
DIN	2615	Tees
DIN	2616	Reducers
DIN	2617	Caps

ISO (International Organization for Standardization)

ISO	1127	Dimensions, tolerances and weights of stainless steel tubes.
-----	------	--

EN (European Standards)

EN	10088-1	List of corrosion resistant steel types
EN	10204	Types of inspection documents
EN	10296 -2	Welded round stainless steel tubes for general applications
EN	10297-2	Seamless round austenitic stainless steel tubes for general applications
EN	10217-7	Welded round austenitic stainless steel tubes for special applications
EN	ISO 1127	Tolerance for stainless steel welded tube
EN	EN 1092-1 type 5 PN 6-100	Blind flanges PN 6-100
EN	EN 1092-1 type 1 PN 10	Flat welding flanges PN 10
EN	EN 1092-1 type 11 PN 10	Welding neck flanges PN 10
EN	EN 1092-1 type 11 PN 16	Welding neck flanges PN 16
EN	EN 1092-1 type 11 PN 25	Welding neck flanges PN 25
EN	EN 1092-1 type 11 PN 40	Welding neck flanges PN 40
EN	EN 1092-1 PN 64	Welding neck flanges PN 64
EN	EN 1092-1 PN 10	Collar rings and flanges PN 10

NFA (French Standards)

NFA	49117	Seamless pipes.
NFA	49147	Longitudinal welded pipes.
NFA	29203	Non alloy, alloy, austenitic stainless steel flanges and collars.

ASTM/ASME/MSS/DIN/NFA Normierungen**ASTM (American Society for Testing and Materials)****ASME (American Society of Mechanical Engineers)**

ASTM/ASME	A	182	Geschmiedete Fittings, Flansche und Ventile aus nichtrostendem Stahl.
ASTM/ASME	A	213	Nahtlose Rohre aus nichtrostendem Stahl, u.a. für Wärmetauscher und Verdampfer.
ASTM/ASME	A	249	Geschweißte Rohre, ohne Zusatzmaterial geschweißt, u.a. für Kondensatoren und Wärmetauscher.
ASTM/ASME	A	269	Nahtlose und geschweißte Rohre aus nichtrostendem Stahl für allgemeine Verwendung mit engen Toleranzen.
ASTM/ASME	A	312	Nahtlose und geschweißte Rohre (geschweißte Rohre ohne Zusatzmaterial) für allgemeine Verwendung.
ASTM/ASME	A	358	Geschweißte Rohre mit Zusatzmaterial. Klasse 1 beidseitig geschweißt und 100% radiographisch geprüft. Klasse 2 beidseitig geschweißt ohne radiographische Prüfung. Klasse 3 einseitig geschweißt und 100% radiographisch geprüft. Klasse 4 einseitig geschweißt, Schweißnaht an der Innenseite des Rohrs, ohne Zusatzmaterial und 100% radiographisch geprüft. Klasse 5 beidseitig geschweißt und lokal radiographisch geprüft.
ASTM/ASME	A	403	Schweißfittings aus nichtrostendem Stahl.
ASTM/ASME	A	409	Geschweißte austenitische Rohre (großer Durchmesser) für Verwendung bei Korrosion oder hoher Temperatur.
ASTM/ASME	A	450	Allgemeine Norm für legiertes Kohlenstoffstahlrohr sowie legiertes ferritisches und austenitisches Stahlrohr.
ASTM/ASME	A	451	Norm für zentrifugal gegossenes Rohr aus nichtrostendem Stahl.
ASTM/ASME	A	473	Hitzebeständige Schmiedestücke aus nichtrostendem Stahl.

ANSI (American National Standards Institute)

ASME	B	16.5	Flansche aus nichtrostendem Stahl nach ASTM.
ASME	B	16.9	Fittings aus nichtrostendem Stahl nach ASTM.
ASME	B	16.11	Geschmiedete Schweiß- und Gewindefittings nach ASTM.
ASME	B	16.25	Form von Schweißschrauben.

MSS (Manufacturers Standardization Society)

MSS	SP	6	Dichtungsflächen von Flanschen.
MSS	SP	25	Markierungssystem für ASTM-Fittings-, -Flansche und -Kupplungen.
MSS	SP	43	ASTM-Schweißfittings.

DIN (Deutsche Industrie Norm)

DIN	17458	Nahtlose kreisförmige Rohre aus austenitischen, nichtrostenden Stählen für besondere Verwendung
DIN	2353	Rohrgewindeverbindung mit Schneidring
DIN	2462	Toleranzen für nahtloses Rohr aus nichtrostendem Stahl
DIN	2605	Bogen
DIN	2606	Bogen
DIN	2615	Schweiß-T-Stücke
DIN	2616	Schweiß- Reduzierstücke
DIN	2617	Schweißhelme

ISO (International Organization for Standardization)

ISO	1127	Maße, Toleranzen und Gewichte von Röhren aus nichtrostendem Stahl.
-----	------	--

EN (Europäische Normen)

EN	10088-1	Liste korrosionsbeständiger Stahlsorten
EN	10204	Prüfungsdokumenten
EN	10296 -2	Geschweißte kreisförmige Rohre aus nichtrostenden Stählen für allgemeine Verwendung
EN	10297-2	Nahtlose kreisförmige Rohre aus nichtrostenden Stählen für allgemeine Verwendung
EN	10217-7	Geschweißte kreisförmige Rohre aus nichtrostenden Stählen für besondere Verwendung
EN	ISO 1127	Toleranzen für geschweißtes Rohr aus nichtrostendem Stahl
EN	EN 1092-1 type 5 PN 6-100	Blindflansche Nenndruck 10
EN	EN 1092-1 type 1 PN 10	Flache Anschweißflansche Nenndruck 10
EN	EN 1092-1 type 11 PN 10	Vorschweißflansche Nenndruck 10
EN	EN 1092-1 type 11 PN 16	Vorschweißflansche Nenndruck 16
EN	EN 1092-1 type 11 PN 25	Vorschweißflansche Nenndruck 25
EN	EN 1092-1 type 11 PN 40	Vorschweißflansche Nenndruck 40
EN	EN 1092-1 PN 64	Vorschweißflansche Nenndruck 64
EN	EN 1092-1 PN 10	Lose Flansche, Vorschweißböden, Glatte Bunde Nenndruck 10

NFA (Französische Normierungen)

NFA	49117	Nahtlose Rohren.
NFA	49147	Geschweißte Rohren.
NFA	29203	Ungelegierte, gelegierte, nicht rostende austenitische stahl Flansche und Bunde.

Normes ASTM/ASME/MSS/DIN/NFA**ASTM (American Society for Testing and Materials)****ASME (American Society of Mechanical Engineers)**

ASTM/ASME	A	182	Brides, valves et raccords forgés en acier inoxydable.
ASTM/ASME	A	213	Tubes sans soudure en acier inoxydable, notamment pour les échangeurs thermiques et les évaporateurs.
ASTM/ASME	A	249	Tubes soudés en acier inoxydable, notamment pour les condenseurs et les échangeurs thermiques.
ASTM/ASME	A	269	Tubes soudés et sans soudure en acier inoxydable pour des applications générales nécessitant des tolérances serrées.
ASTM/ASME	A	312	Tubes soudés et sans soudure (tubes soudés sans matériau d'apport) pour des applications générales.
ASTM/ASME	A	358	Tubes soudés avec matériau d'apport. Classe 1, soudés des deux côtes avec 100% de radiographie. Classe 2, soudés des deux côtes sans radiographie. Classe 3, soudés avec 100% de radiographie. Classe 4, soudés, premier pas sans apport de matière avec 100% de radiographie. Classe 5, soudés des deux côtes avec contrôle radiographie aléatoire.
ASTM/ASME	A	403	Raccords en acier inoxydable.
ASTM/ASME	A	409	Tubes austénitiques soudés (large diamètre) pour des applications corrosives ou à haute température.
ASTM/ASME	A	450	Norme générale pour tube en acier carbon alié, ferritique et austénitique.
ASTM/ASME	A	451	Norme pour tube en acier inoxydable coulé par coulée centrifugeage.
ASTM/ASME	A	473	Raccords forgés en acier inoxydable et acier 'haute température'.

ANSI (American National Standards Institute)

ASME	B	16.5	Brides en acier inoxydable conformes aux normes ASTM.
ASME	B	16.9	Raccord en acier inoxydable conformes aux normes ASTM.
ASME	B	16.11	Raccords forgés filetés et non filetés conformes aux normes ASTM.
ASME	B	16.25	Formes des chanfrein.

MSS (Manufacturers Standardization Society)

MSS	SP	6	Faces de joint des brides.
MSS	SP	25	Système de marquage pour brides, valves et raccords ASTM.
MSS	SP	43	Raccords ASTM.

DIN (Deutsche Industrie Norm)

DIN	17458	Tubes circulaires sans soudure austénitiques en acier inoxydable pour des applications spéciales
DIN	2353	Raccord fileté pour tube avec baque coupante
DIN	2462	Tolérances pour tube en acier inoxydable sans soudure
DIN	2605	Coudes
DIN	2606	Coudes
DIN	2615	Tes
DIN	2616	Réductions
DIN	2617	Fonds

ISO (Organisation internationale de normalisation)

ISO	1127	Dimensions, tolérances et poids des tubes en acier inoxydables.
-----	------	---

EN (Normes européennes)

EN	10088-1	Liste des types d'acier résistant à la corrosion
EN	10204	Types de documents de vérification
EN	10296-2	Tubes circulaires soudés en acier inoxydable pour des applications générales
EN	10297-2	Tubes circulaires sans soudure en acier inoxydable pour des applications générales
EN	10217-7	Tubes circulaires soudés austénitiques en acier inoxydable pour des applications spéciales
EN	ISO 1127	Tolérances pour tube en acier inoxydable soudé
EN	EN 1092-1 type 5 PN 6-100	Brides pleines PN 6- 100
EN	EN 1092-1 type 1 PN 10	Brides plates à souder PN 10
EN	EN 1092-1 type 11 PN 10	Brides à collerette à souder PN 10
EN	EN 1092-1 type 11 PN 16	Brides à collerette à souder PN 16
EN	EN 1092-1 type 11 PN 25	Brides à collerette à souder PN 25
EN	EN 1092-1 type 11 PN 40	Brides à collerette à souder PN 40
EN	EN 1092-1 PN 64	Brides à collerette à souder PN 64
EN	EN 1092-1 PN 10	Collets et brides PN 10

NFA (Normes Françaises)

NFA	49117	Tubes sans soudee.
NFA	49147	Tubes soudés longitudinalement.
NFA	29203	Brides et collets, en acier, non alliés, alliés inoxydable austénitiques.

ANSI pijp afmetingen en gewichten
ANSI pipe dimensions and weights
ANSI Rohrabmessungen und Gewichte
Dimensions et poids des tubes
conformément aux normes ANSI

Pijp afmetingen volgens ANSI B36.19

Pipe schedule acc. to ANSI B36.19

Rohrabmessungen nach ANSI B36.19

Dimensions des tubes conformément à la norme ANSI B36.19

Nom Bore inch	O.D. mm	O.D. inch	SCH	Wall-thickness mm	Wall - thickness inch	Weight	Nom Bore inch	O.D. mm	O.D. inch	SCH	Wall-thickness mm	Wall - thickness inch	Weight
1/8"	10,29	0.405	5S				4"	114,30	4.500	5S	2,11	0.083	5,83
			10S	1,24	0.049	0,28				10S	3,05	0.120	8,35
			40S	1,73	0.068	0,36				40S	6,02	0.237	16,06
			80S	2,41	0.095	0,46				80S	8,56	0.337	22,29
1/4"	13,72	0.540	5S				5"	141,30	5.563	5S	2,77	0.100	9,46
			10S	1,65	0.065	0,49				10S	3,40	0.134	11,56
			40S	2,23	0.088	0,62				40S	6,55	0.258	21,75
			80S	3,02	0.119	0,80				80S	9,52	0.375	30,92
3/8"	17,15	0.675	5S				6"	168,28	6.625	5S	2,77	0.109	11,31
			10S	1,65	0.065	0,62				10S	3,40	0.134	13,82
			40S	2,31	0.091	0,85				40S	7,11	0.280	28,23
			80S	3,20	0.126	1,10				80S	10,97	0.432	42,51
1/2"	21,34	0.840	5S	1,65	0.065	0,80	8"	219,08	8.625	5S	2,77	0.109	14,78
			10S	2,11	0.083	1,00				10S	3,76	0.148	19,94
			40S	2,77	0.109	1,26				40S	8,18	0.322	42,48
			80S	3,73	0.147	1,62				80S	12,70	0.500	64,56
3/4"	26,67	1.050	5S	1,65	0.065	1,03	10"	273,05	10.750	5S	3,40	0.134	22,60
			10S	2,11	0.083	1,28				10S	4,19	0.165	27,75
			40S	2,87	0.113	1,68				40S	9,27	0.365	60,23
			80S	3,91	0.154	2,19				80S	12,70	0.500	81,45
1"	33,40	1.315	5S	1,65	0.065	1,29	12"	323,85	12.750	5S	3,96	0.156	31,22
			10S	2,77	0.109	2,08				10S	4,57	0.180	35,96
			40S	3,38	0.133	2,50				40S	9,52	0.375	73,74
			80S	4,55	0.179	3,23				80S	12,70	0.500	97,34
1.1/4"	42,16	1.660	5S	1,65	0.065	1,65	14"	355,60	14.000	5S	3,96	0.156	34,33
			10S	2,77	0.109	2,69				10S	4,77	0.188	41,26
			40S	3,56	0.140	3,38				40S			
			80S	4,85	0.191	4,46				80S			
1.1/2"	48,26	1.900	5S	1,65	0.065	1,90	16"	406,40	16.000	5S	4,19	0.165	41,51
			10S	2,77	0.109	3,11				10S	4,77	0.166	47,24
			40S	3,68	0.145	4,05				40S			
			80S	5,08	0.200	5,40				80S			
2"	60,32	2.375	5S	1,65	0.065	2,40	18"	457,20	18.000	5S	4,19	0.165	46,77
			10S	2,77	0.109	3,93				10S	4,77	0.188	53,21
			40S	3,91	0.154	5,43				40S			
			80S	5,54	0.218	7,47				80S			
2.1/2"	73,02	2.875	5S	2,11	0.083	3,69	20"	508,00	20.000	5S	4,77	0.188	59,19
			10S	3,05	0.120	5,25				10S	5,53	0.218	68,54
			40S	5,16	0.203	8,62				40S			
			80S	7,01	0.276	11,40				80S			
3"	88,90	3.500	5S	2,11	0.083	4,51	22"	558,80	22.000	5S	4,77	0.188	65,17
			10S	3,05	0.120	6,44				10S	5,53	0.218	75,45
			40S	5,49	0.216	11,28				40S			
			80S	7,62	0.300	15,25				80S			
3.1/2"	101,60	4.000	5S	2,11	0.083	5,18	24"	609,40	24.000	5S	5,53	0.218	82,39
			10S	3,05	0.120	7,40				10S	6,35	0.250	94,35
			40S	5,74	0.226	13,56				40S			
			80S	8,08	0.318	18,61				80S			

Pijp afmetingen volgens ANSI B36.10
 Pipe schedule acc. to ANSI B36.10
 Rohrabmessungen nach ANSI B36.10
 Dimensions des tubes conformément à la norme ANSI B36.10

Nom Bore inch	O.D. mm	O.D. inch	STD XS XXS	SCH	Wall-thickness mm	Wall - thickness inch	Weight	Nom Bore inch	O.D. mm	O.D. inch	STD XS XXS	SCH	Wall-thickness mm	Wall - thickness inch	Weight		
1/8"	10,29	0.405	STD	10	1,24	0.049	0,28	1.1/2"	48,26	1.900	STD	5	1,65	0.065	1,90		
				30	1,45	0.057	0,32						10	2,77	0.109	3,11	
				40	1,73	0.068	0,37						30	3,18	0.125	3,53	
				80	2,41	0.095	0,47						40	3,68	0.145	4,05	
1/4"	13,72	0.540	XS	10	1,65	0.065	0,49	XS	80	5,08	0.200	160	7,14	0.281	7,25		
				30	1,85	0.073	0,54						10,16	0.400	9,55		
				40	2,24	0.088	0,63						5	1,65	0.065	2,39	
				80	3,02	0.119	0,80						10	2,77	0.109	3,93	
3/8"	17,15	0.675	STD	10	1,65	0.065	0,63	2"	60,32	2.375	STD	30	3,18	0.125	4,48		
				30	1,85	0.073	0,70						40	3,91	0.154	5,44	
				40	2,31	0.091	0,84						80	5,54	0.218	7,48	
				80	3,20	0.126	1,10						160	8,74	0.344	11,11	
1/2"	21,34	0.840	XS	5	1,65	0.065	0,80	XXS	2.1/2"	73,02	2.875	STD	40	5,16	0.203	8,63	
				10	2,11	0.083	1,00							80	7,01	0.276	11,41
				30	2,41	0.095	1,12							160	9,53	0.375	14,92
				40	2,77	0.109	1,27							XXS	14,02	0.552	20,39
				80	3,73	0.147	1,62							5	2,11	0.083	3,69
				160	4,78	0.188	1,95							10	3,05	0.120	5,26
3/4"	26,67	1.050	STD	5	1,65	0.065	1,03	3"	88,90	3.500	STD	30	4,78	0.188	8,04		
				10	2,11	0.083	1,28						40	5,16	0.203	8,63	
				30	2,41	0.095	1,44						80	7,01	0.276	11,41	
				40	2,87	0.113	1,69						160	9,53	0.375	14,92	
				80	3,91	0.154	2,20						XXS	14,02	0.552	20,39	
				160	5,56	0.219	2,90						5	2,11	0.083	4,52	
1"	33,40	1.315	XS	5	1,65	0.065	1,29	3.1/2"	101,60	4.000	STD	40	5,49	0.216	11,29		
				10	2,77	0.109	2,09						80	7,62	0.300	15,27	
				30	2,90	0.114	2,18						160	11,13	0.438	21,35	
				40	3,38	0.113	2,50						XXS	15,24	0.600	27,68	
				80	4,55	0.179	3,24						5	2,11	0.083	5,18	
				160	6,35	0.250	4,24						10	3,05	0.120	7,41	
1.1/4"	42,16	1.660	STD	5	1,65	0.065	1,65	4"	114,30	4.500	STD	30	4,78	0.188	11,41		
				10	2,77	0.109	2,69						40	5,74	0.226	13,57	
				30	2,97	0.117	2,87						80	8,08	0.318	18,64	
				40	3,56	0.140	3,39						5	2,11	0.083	5,84	
				80	4,85	0.191	4,47						10	3,05	0.120	8,37	
				160	6,35	0.280	5,61						30	4,78	0.188	12,91	
XXS	9,70	0.382	7,77	40	3,56	0.140	3,39	STD	40	6,02	0.237	120	11,13	0.438	28,32		
				80	4,85	0.191	4,47						160	13,49	0.531	33,54	
				160	6,35	0.280	5,61						XXS	17,12	0.674	41,03	
				9,70	0.382	7,77											

Pijp afmetingen volgens ANSI B36.10
 Pipe schedule acc. to ANSI B36.10
 Rohrabmessungen nach ANSI B36.10
 Dimensions des tubes conformément à la norme ANSI B36.10

Nom Bore inch	O.D. mm	O.D. inch	STD XS XXS	SCH	Wall-thickness mm	Wall - thickness inch	Weight	Nom Bore inch	O.D. mm	O.D. inch	STD XS XXS	SCH	Wall-thickness mm	Wall - thickness inch	Weight		
5"	141,30	5.563	STD	XS	5	2,77	0.109	9,46	12"	323,85	10.750	STD	5	3,96	0.156	31,24	
					10	3,40	0.134	11,56					10	4,57	0.180	35,98	
					40	6,55	0.258	21,77					20	6,35	0.250	49,71	
					80	9,53	0.375	30,97					30	8,38	0.330	65,19	
					120	12,70	0.500	40,23					40	9,53	0.375	73,86	
					160	15,88	0.625	49,12					60	10,31	0.406	79,71	
					190,05	0.750	57,43	120					12,70	0.500	40,23		
6"	168,28	6.625	STD	XS	5	2,77	0.109	11,31	14"	355,60	14.000	XS	5	3,96	0.156	34,34	
					10	3,40	0.134	13,83					10	6,35	0.250	54,69	
					40	7,11	0.280	28,26					20	7,93	0.312	67,91	
					80	10,97	0.432	42,56					STD	30	9,53	0.375	81,33
					120	14,28	0.562	54,21					40	11,13	0.438	94,55	
					160	18,26	0.719	67,57					60	12,70	0.500	107,40	
					219,95	0.864	79,22	80					12,70	0.500	64,64		
8"	219,08	8.625	STD	XS	5	2,77	0.109	14,78	16"	406,40	16.000	STD	5	4,19	0.165	41,56	
					10	3,76	0.148	19,97					10	6,35	0.250	62,65	
					20	6,35	0.250	33,32					20	7,93	0.312	77,83	
					30	7,04	0.277	36,82					XS	30	9,53	0.375	93,27
					40	8,18	0.322	42,55					40	12,70	0.500	123,31	
					60	10,31	0.406	53,09					60	16,66	0.656	160,13	
					80	12,70	0.500	64,64					80	21,44	0.844	203,54	
					100	15,09	0.594	75,92					100	26,19	1.031	245,57	
					120	18,26	0.719	90,44					120	30,96	1.219	286,66	
					140	20,63	0.812	100,93					140	36,53	1.438	333,21	
					160	23,01	0.906	111,27					160	40,49	1.594	365,38	
10"	273,05	10.750	STD	XS	5	3,40	0.134	22,61	16"	406,40	16.000	STD	5	4,19	0.165	41,56	
					10	4,19	0.165	27,78					10	6,35	0.250	62,65	
					20	6,35	0.250	41,76					20	7,93	0.312	77,83	
					30	7,80	0.307	51,01					XS	30	9,53	0.375	93,27
					40	9,27	0.365	60,29					40	12,70	0.500	123,31	
					60	12,70	0.500	81,53					60	16,66	0.656	160,13	
					80	15,09	0.594	95,98					80	21,44	0.844	203,54	
					100	18,26	0.719	114,71					100	26,19	1.031	245,57	
					120	21,44	0.844	133,01					120	30,96	1.219	286,66	
					140	25,40	1.000	155,10					140	36,53	1.438	333,21	
					160	28,58	1.125	172,27					160	40,49	1.594	365,38	

Pijp afmetingen volgens ANSI B36.10
 Pipe schedule acc. to ANSI B36.10
 Rohrabmessungen nach ANSI B36.10
 Dimensions des tubes conformément à la norme ANSI B36.10

Nom Bore inch	O.D. mm	O.D. inch	STD XS XXS	SCH	Wall-thickness mm	Wall - thickness inch	Weight	Nom Bore inch	O.D. mm	O.D. inch	STD XS XXS	SCH	Wall-thickness mm	Wall - thickness inch	Weight	
18"	457,20	18.000	STD	5	4,19	0.165	46,79	24"	609,40	24.000	STD	5	5,54	0.218	82,58	
				10	6,35	0.250	70,57					10	6,35	0.250	94,53	
				20	7,93	0.312	87,71					20	9,53	0.375	141,12	
					9,53	0.375	105,17					XS		12,70	0.500	187,07
				30	11,13	0.438	122,38						30	14,28	0.562	209,85
					12,70	0.500	139,16					40	17,48	0.688	255,43	
				40	14,28	0.562	155,81					60	24,61	0.969	355,28	
				60	19,05	0.750	205,75					80	30,96	1.219	442,11	
				80	23,83	0.938	254,57					100	38,89	1.531	547,74	
				100	29,36	1.156	309,64					120	46,03	1.812	640,07	
				120	34,94	1.375	363,58					140	52,38	2.062	720,19	
				140	39,68	1.562	408,28					160	59,54	2.344	808,27	
				160	45,24	1.781	459,39									
				20"	508,00	20.000	STD					5	4,78	0.188	59,32	
10	6,35	0.250	78,56													
20	9,53	0.375	117,15													
XS	30	12,70	0.500					155,13								
	40	15,09	0.594					183,43								
60	20,63	0.812	247,84													
80	26,19	1.031	311,19													
100	32,54	1.281	381,55													
120	38,10	1.500	441,52													
140	44,45	1.750	508,15													
160	50,01	1.969	564,85													
22"	558,80	22.000	STD	5	4,78	0.188	65,33									
				10	6,35	0.250	86,55									
				20	9,53	0.375	129,14									
				XS	30	12,70	0.500	171,10								
					60	22,23	0.875	294,27								
				80	28,58	1.125	373,85									
				100	34,93	1.375	451,45									
				120	41,28	1.625	527,05									
				140	47,63	1.875	600,67									
				160	53,98	2.125	672,30									

BWG en SWG afmetingen en gewichten
BWG and SWG dimensions and weight
BWG und SWG Abmessungen und Gewichte
Dimensions et poids conformément aux normes
BWG et SWG

BWG-S (Birmingham Wire Gauge)

BD		22	22	20	20	18	18	16	16	14	14	12	12	11	11	10	10	
UD		inch	mm	inch	mm	inch	mm	inch	mm	inch	mm	inch	mm	inch	mm	inch	mm	
AD		.028	.711	.035	.889	.049	1.244	.065	1.650	.083	2.108	.109	2.768	.120	3.047	.134	3.403	
	inch	mm	lb/ft	kg/m	lb/ft	kg/m	lb/ft	kg/m	lb/ft	kg/m	lb/ft	kg/m	lb/ft	kg/m	lb/ft	kg/m	lb/ft	kg/m
1/4"	6.350			.082	.122	.107	.159	.130	.194									
5/16"	7.950			.106	.157	.140	.209	.175	.260									
3/8"	9.525			.129	.192	.173	.258	.219	.326	.263	.392							
1/2"	12.700	.143	.213	.177	.263	.240	.357	.307	.457	.376	.559	.362	.688	.495	.737			
5/8"	15.875	.181	.270	.224	.334	.306	.456	.395	.588	.489	.727	.610	.908	.658	.979			
3/4"	19.050			.271	.404	.373	.555	.483	.719	.601	.894	.759	1.130	.820	1.220	.894	1.33	
7/8"	22.225	.257	.383	.319	.475	.439	.654	.572	.851	.712	1.060	.907	1.350	.981	1.460	1.080	1.60	
1"	25.400	.296	.440	.367	.546	.505	.752	.660	.982	.826	1.230	1.060	1.570	1.150	1.710	1.260	1.87	
1.1/4"	31.750	.372	.553	.462	.687	.638	.950	.833	1.240	1.060	1.570	1.350	2.010	1.470	2.190	1.630	2.42	
1.1/2"	38.100	.448	.666	.556	.828	.773	1.150	1.010	1.510	1.280	1.900	1.650	2.450	1.800	2.680	1.990	2.96	
1.3/4"	44.450	.523	.779	.652	.970	.907	1.350	1.190	1.770	1.510	2.240	1.940	2.890	2.120	3.160	2.350	3.50	
2"	50.800	.599	.892	.746	1.110	1.040	1.540	1.360	2.030	1.730	2.570	2.240	3.330	2.450	3.650	2.710	4.04	
2.1/2"	63.500					1.300	1.940	1.720	2.560	2.180	3.240	2.830	4.210	3.100	4.610	3.440	5.12	
3"	76.200					1.570	2.340	2.700	3.080	2.630	3.910	3.420	5.090	3.750	5.580	4.170	6.20	
3.1/2"	88.900					1.830	2.730	2.430	3.610	3.080	4.580	4.010	5.970	4.400	6.550	4.900	7.29	
4"	101.600					2.100	3.130	2.780	4.130	3.530	5.250	4.600	6.850	5.050	7.520	5.620	8.37	

SWG-S (Standard Wire Gauge)

BD		22	22	20	20	18	18	16	16	14	14	12	12	11	11	10	10	
UD		inch	mm	inch	mm	inch	mm	inch	mm	inch	mm	inch	mm	inch	mm	inch	mm	
AD		0.28	.711	.036	.914	.048	1.218	.064	1.625	.080	2.032	.104	2.641	.116	2.946	.128	3.251	
	inch	mm	lb/ft	kg/m	lb/ft	kg/m	lb/ft	kg/m	lb/ft	kg/m	lb/ft	kg/m	lb/ft	kg/m	lb/ft	kg/m	lb/ft	kg/m
1/4"	6.350			.083	.124	.105	.157	.129	.192									
5/16"	7.950			.108	.161	.138	.205	.173	.257									
3/8"	9.525			.132	.197	.170	.253	.216	.321	.256	.381							
1/2"	12.700	.143	.213	.181	.270	.235	.350	.303	.451	.365	.543	.447	.665	.484	.720			
5/8"	15.875	.181	.270	.230	.342	.300	.447	.390	.580	.473	.704	.588	.875	.641	.954			
3/4"	19.050			.279	.415	.366	.544	.476	.709	.582	.866	.732	1.090	.800	1.190	.867	1.29	
7/8"	22.225	.257	.383	.328	.488	.431	.641	.563	.838	.692	1.030	.874	1.300	.954	1.420	1.040	1.55	
1"	25.400	.296	.440	.376	.560	.496	.738	.650	.967	.800	1.190	1.020	1.510	1.120	1.660	1.210	1.80	
1.1/4"	31.750	.372	.553	.474	.706	.626	.931	.827	1.230	1.020	1.510	1.300	1.930	1.430	2.130	1.560	2.32	
1.1/2"	38.100	.448	.666	.572	.851	.759	1.130	.994	1.480	1.240	1.840	1.580	2.350	1.740	2.590	1.910	2.84	
1.3/4"	44.450	.523	.779	.669	.996	.887	1.320	1.170	1.740	1.450	2.160	1.860	2.770	2.060	3.060	2.250	3.35	
2"	50.800	.599	.892	.766	1.140	1.020	1.510	1.340	2.000	1.670	2.480	2.140	3.190	2.370	3.530	2.600	3.87	
2.1/2"	63.500					1.280	1.900	1.690	2.520	2.100	3.130	2.710	4.030	3.000	4.470	3.300	4.91	
3"	76.200					1.540	2.290	2.000	3.030	2.530	3.770	3.270	4.870	3.630	5.400	3.990	5.94	
3.1/2"	88.900					1.790	2.670	2.390	3.550	2.970	4.420	3.830	5.700	4.260	6.340	4.680	6.97	
4"	101.600					2.060	3.060	2.740	4.070	3.410	5.070	4.400	6.540	4.890	7.280	5.380	8.01	

Benaderende vergelijkingstabel

Approximate comparison table

Ungefähre Vergleichstabelle

Tableau comparatif approximatif

De normen die overeenkomen met DIN - Werkstoffnummers kunnen slechts bij benadering vergeleken worden.

De inzetbaarheid van deze equivalenten moet afzonderlijk beoordeeld worden.

The standards that correspond with DIN Material Numbers can only be compared approximately.

The use of these equivalents has to be evaluated on a case-by-case basis.

Die Normen, die den DIN-Werkstoffnummern entsprechen, können nur annähernd verglichen werden.

Die Benutzung dieser Äquivalente ist für jeden Einzelfall zu beurteilen.

Les normes qui correspondent à la nomenclature DIN peuvent uniquement être comparées de manière approximative.

L'utilisation de ces équivalents doit être considérée séparément.

W.-Nr.	DIN	EN	AISI 1)	UNS 2)	SS 3)	AFNOR 4)	BS 5)
1.4005	X 12 CrS 13	X 12 CrS 13	416	S 41600	2380	Z 11 CF 13	416 S 21
1.4006	X 10 Cr 13	X 12 Cr 13	410	S 41000	2302	Z 12 C 13	410 S 21
1.4016	X 6 Cr 17	X 6 Cr 17	430	S 43000	2320	Z 10 C 17	430 S 15
1.4021	X 20 Cr 13	X 20 Cr 13	420	S 42000	2303	Z 20 C 13	420 S 37
1.4034	X 46 Cr 13	X 46 Cr 13			[2304]	Z 40 C 14	[420 S 45]
1.4057	X 20 CrNi 17 2	X 17 CrNi 16 2	431	S 43100	2321	Z 15 CN 16.02	431 S 29
1.4104	X 12 CrMoS 17	X 14 CrMoS 17	430 F	S 43020	2383	Z 13 CF 17	[441 S 29]
1.4112	X 90 CrMoV 18	X 90 CrMoV 18	440 B	S 44003	2327	Z 2 CND 18 05	
1.4122	X 35 CrMo 17	X 39 CrMo 17 1					
1.4301	X 5 CrNi 18 10	X 5 CrNi 18 10	304	S 30400	2333	Z 6 CN 18.09	304 S 15
1.4305	X 10 CrNiS 18 9	X 8 CrNiS 18 9	303	S 30300	2346	Z 8 CNF 18.09	303 S 31
1.4306	X 2 CrNi 19 11	X 2 CrNi 19 11	304 L	S 30403	2352	Z 2 CN 18.10	304 S 11
1.4307	X 2 CrNi 18 9	X 2 CrNi 18 9	304 L		2352	Z 3 CN 18.10	304 S 11
1.4310	X 12 CrNi 17 7	X 10 CrNi 18 8	301	S 30100	2331	Z 12 CN 18.08	301 S 21
1.4311	X 2 CrNiN 18 10	X 2 CrNiN 18 10	304 LN	S 30453	2371	Z 2 CN 18.10 Az	301 S 21
1.4362	X 2 CrNiN 23 4	X 2 CrNiN 23 4		S 31500	2327	Z 2 CND 18.05	
1.4401	X 5 CrNiMo 17 12 2	X 5 CrNiMo 17 12 2	316	S 31600	2347	Z 7 CND 17.12.02	316 S 31
1.4404	X 2 CrNiMo 17 13 2	X 2 CrNiMo 17 12 2	316 L	S 31603	2348	Z 3 CND 18.12.02	316 S 11
1.4435	X 2 CrNiMo 18 14 3	X 2 CrNiMo 18 14 3	316 L	S 31603	2353	Z 3 CND 18.14.03	316 S 11
1.4436	X 5 CrNiMo 17 13 3	X3 CrNiMo 17 13 3	316	S 31600	2343	Z 7 CND 18.12.03	316 S 31
1.4438	X 2 CrNiMo 18 16 4	X 2 CrNiMo 18 15 4	317 L	S 31703	2367	Z 3 CND 19.15.04	317 S 12
1.4439	X 2 CrNiMoN 17 13 5	X 2 CrNiMoN 17 13 5	317 LNM	S 31726		Z 2CNDU 17.16	
1.4449	X 5 CrNiMo 17 13		317	S 31700			317 S 16
1.4460	X 4 CrNiMoN 27 5 2	X 3 CrNiMoN 27 5 2	329	S 32900	2324	Z 5 CND 27.05 Az	
1.4462	X 2 Cr Ni MoN 22 5 3	X 2 Cr Ni MoN 22 5 3		S 31803	2377	Z 2 CND 22.05 Az	
1.4465	X 1 CrNiMoN 25 25 2			S 31050		Z 2 CND 25.22 Az	
1.4539	X 1 NiCrMoCuN 25 20 5	X 1 NiCrMoCuN 25 20 5		N 08904	2562	Z 1 NCDU 25.20	
1.4541	X 6 CrNiTi 18 10	X 6 CrNiTi 18 10	321	S 32100	2337	Z 6 CNT 18.10	321 S 31
1.4550	X 6 CrNiNb 18 10	X 6 CrNiNb 18 10	347	S 34700	2338	Z 6 CNNb 18.10	347 S 31
1.4571	X 6 CrNiMoTi 17 12 2	X 6 CrNiMoTi 17 12 2	316 Ti	S 31635	2350	Z 6 CNDT 17.12	320 S 31
1.4713	X 10 CrAl 7					Z 8 CA 7	
1.4724	X 10 CrAl 13					[Z 10 C 13]	
1.4742	X 10 CrAl 18					Z 10 CAS 18	
1.4749	X 18 CrN 28		446 - 1	S 44600	2322		
1.4762	X 10 CrAl 24		[446]	[S44600]	[2322]	Z 10 CAS 24	
1.4821	X 20 CrNiSi 25 4					Z 20 CNS 25.04	
1.4828	X 15 CrNiSi 20 12		309	[S 30900]		Z 15 CNS 20.12	309 S 24
1.4841	X 15 CrNi 25 20		314	S 31400		Z 12 CNS 25.20	314 S 25
1.4845	X 12 CrNi 25 21		310 S	S 31008	2361	Z 12 CN 25 20	310 S 24
1.4864	X 12 NiCrSi 36 16		330	N 08330		Z 12 CNS 35.16	[3076 NA 17]
1.4876	X 10 NiCrAlTi 32 20		B 163			Z 8 NC 32.21	3076 NA 15 H
1.4878	X 12 CrNiTi 18 9		321	S 32100	2337	Z 6 CNT 18.12	321 S 51
2.4068	LC Ni 99		B 160				
2.4360	Ni Cu 30 Fe		B 164				3076 NA 13
2.4375	Ni Cu 30 Al						3076 NA 18
2.4610	Ni Mo 16 Cr 16 Ti						3076 NA 45
2.4816	Ni Cr 15 Fe		B 166				3076 NA 14
2.4856	Ni Cr 21 Mo						3076 NA 43

1) AISI = American Iron and Steel Institute

ASTM = American Society for Testing and Materials

2) UNS = Unified Numbering Systems

3) SS = Swedish Standard

4) AFNOR = Association Française de Normalisation

5) BS = British Standard

Vergelijkingstabel naamsaanduiding roestvaststaal
Comparison table different names of stainless steel
Vergleichungstabelle Edeltahlnamsandeutung
Tableau comparatif des différentes appellations
d'acier inoxydable

Kwaliteit/Grade/Güte/Qualité

Roestvaststaal type 316

Stainless Steel type 316

Edelstahl type 316

Acier inoxydable 316

	C Max.	Si Max.	Mn Max.	P Max.	S Max.	Cr	Ni	Mo
DIN W.-Nr.1. 4401 (X5CrNiMo 17 122)	0.07	1.00	2.00	0.045	0.030	16.5-18.5	10.5-13.5	2.0-2.5
SIS 2343	0.07	1.00	2.00	0.045	0.025	16.5-18.5	11.0-14.0	2.5-3.0
AISI-TP 316	0.08	0.75	2.00	0.040	0.030	16.0-18.0	11.0-14.0	2.0-3.0
BS GRADE 316S 18	0.07	0.20-1.00	0.50-2.00	0.040	0.030	16.0-18.5	11.0-14.0	2.0-3.0
SIS 2347	0.05	1.00	2.00	0.045	0.030	16.0-18.5	10.5-14.0	2.0-2.5
afnor z 6 cnd 17-11	0.07	1.00	2.00	0.040	0.030	16.0-18.0	10.0-12.5	2.0-2.7
JIS-SUS 316 (SUS 32 B)	0.08	1.00	2.00	0.045	0.030	16.0-18.0	10.0-14.0	2.0-3.0
BS GRADE 316S 25	0.07	0.20-1.00	0.50-2.00	0.045	0.030	16.5-18.5	10.5-13.5	2.0-2.5

Kwaliteit/Grade/Güte/Qualité

Roestvaststaal type 316L

Stainless Steel type 316L

Edelstahl type 316L

Acier inoxydable 316L

	C Max.	Si Max.	Mn Max.	P Max.	S Max.	Cr	Ni	Mo
DIN W.-Nr.1. 4404 (X2CrNiMo 17 132)	0.03	1.00	2.00	0.045	0.030	16.5-18.5	11.0-14.0	2.0-2.5
SIS 2353	0.03	1.00	2.00	0.045	0.025	17.0-18.5	12.5-15.0	2.5-3.0
AISI-TP-316L	0.035	0.75	2.00	0.040	0.030	16.0-18.0	10.0-15.0	2.0-3.0
BS GRADE 316S 14	0.03	0.20-1.00	0.50-2.00	0.040	0.030	16.0-18.5	12.0-15.0	2.0-3.0
SIS 2348	0.03	1.00	2.00	0.045	0.030	16.0-18.5	11.0-14.0	2.0-2.5
AFNOR Z 2 CND 17-12	0.03	1.00	2.00	0.040	0.030	16.0-18.0	10.5-13.0	2.0-2.4
AFNOR Z 2 CND 17-13	0.03	1.00	2.00	0.040	0.030	16.0-18.0	11.5-13.5	2.5-3.0
JIS-SUS 316L (SUS 33 B)	0.03	1.00	2.00	0.045	0.030	16.0-18.0	12.0-15.0	2.0-3.0
BS GRADE 316S 24	0.03	0.20-1.00	0.50-2.00	0.045	0.030	16.5-18.5	11.00-14.0	2.0-2.5

Kwaliteit/Grade/Güte/Qualité

Roestvaststaal type 304

Stainless Steel type 304

Edelstahl type 304

Acier inoxydable 304

	C Max.	Si Max.	Mn Max.	P Max.	S Max.	Cr	Ni	Mo
DIN W.-Nr.1. 4301 (X5CrNi 18 10)	0.07	1.00	2.00	0.045	0.030	17.0-19.0	8.5-10.5	
AISI-TP-304	0.08	0.75	2.00	0.040	0.030	18.0-20.0	8.0-11.0	
BS GRADE 304 S 18	0.06	0.20-1.00	0.50-2.00	0.040	0.030	17.0-19.0	9.0-12.0	
SIS 2332	0.07	1.00	2.00	0.045	0.030	17.0-19.0	8.0-11.0	
AFNOR Z6CN18.09	0.08	1.00	2.00	0.040	0.030	17.0-20.0	8.0-11.00	
JIS-SUS 304 (SUS 27 B)	0.08	1.00	2.00	0.045	0.030	18.0-20.0	8.0-10.5	
BS GRADE 304 S 25	0.06	0.20-1.00	0.50-2.00	0.045	0.030	17.0-19.0	8.0-11.0	

Kwaliteit/Grade/Güte/Qualité

Roestvaststaal type 304L

Stainless Steel type 304L

Edelstahl type 304L

Acier inoxydable 304L

	C Max.	Si Max.	Mn Max.	P Max.	S Max.	Cr	Ni	Mo
DIN W.-Nr.1. 4306 (X2CrNi 1911)	0.03	1.00	2.00	0.045	0.030	18.0-20.0	10.0-12.5	
DIN W.-Nr.1. 4307 (X2CrNi 18 9)	0.03	1.00	2.00	0.045	0.015	17.5-19.5	8.0-10.0	
AISI-TP-304 L	0.03-0.035	0.75	2.00	0.040	0.030	18.0-20.0	8.0-13.0	
BS GRADE 304 S 14	0.03	0.20-1.00	0.50-2.00	0.040	0.030	17.0-19.0	10.0-13.0	
SIS 2352	0.03	1.00	2.00	0.045	0.030	17.0-19.0	9.0-12.0	
AFNOR Z 2 CN 18-10	0.03	1.00	2.00	0.040	0.030	17.0-20.0	9.0-12.0	
JIS-SUS 304 L (SUS 28 B)	0.03	1.00	2.00	0.045	0.030	18.0-20.0	9.0-13.0	
BS GRADE 304 S 22	0.03	0.20-1.00	0.50-2.00	0.045	0.030	17.0-19.0	9.0-12.0	

Kwaliteit/Grade/Güte/Qualité

Roestvaststaal type 321

Stainless Steel type 321

Edelstahl type 321

Acier inoxydable 321

	C Max.	Si Max.	Mn Max.	P Max.	S Max.	Cr	Ni	Mo	Ti Min.
DIN W.-Nr.1. 4541 (X6CrNiTi 18 10)	0.08	1.00	2.00	0.045	0.030	17.0-19.0	9.0-12.0		5xC Max. 0.8
AISI-TP 321	0.08	0.75	2.00	0.040	0.030	17.0-20.0	9.0-13.0		5xC Max. 0.6
BS GRADE 321 S 18	0.08	0.20-1.00	0.50-2.00	0.040	0.030	17.0-19.0	10.0-13.0		5xC Max. 0.6
SIS 2337	0.08	1.00	2.00	0.045	0.030	17.0-19.0	9.0-12.0		5xC Max. 0.8
AFNOR Z 6 CNT 18.10	0.08	1.00	2.00	0.040	0.030	17.0-20.0	9.0-12.0		5xC Max. 0.6
JIS-SUS 321 (SUS 29 B)	0.08	1.00	2.00	0.045	0.030	17.0-19.0	9.0-13.0		5xC
BS GRADE 321 S 22	0.08	0.20-1.00	0.50-2.00	0.045	0.030	17.0-19.0	9.0-12.0		5xC Max. 0.6

Kwaliteit/Grade/Güte/Qualité

Roestvaststaal type Duplex

Stainless Steel type Duplex

Edelstahl type Duplex

Acier inoxydable Duplex

	C Max.	Si Max.	Mn Max.	P Max.	S Max.	Cr	Mo	Ni	N
DIN W.-Nr.1.4462	0.03	1.00	2.0	0.030	0.020	21.0-23.0	2.5-3.5	4.5-6.5	0.08-0.2
SIS 2377	0.03	1.00	2.0	0.030	0.020	21.0-23.0	2.5-3.5	4.5-6.5	0.08-0.2
BS GRADE 318S13	0.03	1.00	2.0	0.030	0.020	21.0-23.0	2.5-3.5	4.5-6.5	0.08-0.2
UNS S 31803	0.03	1.00	2.0	0.030	0.020	21.0-23.0	2.5-3.5	4.5-6.5	0.08-0.2
AFNOR NFA49 -219	0.03	1.00	2.0	0.030	0.020	21.0-23.0	2.5-3.5	4.5-6.5	0.08-0.2

Mechanische eigenschappen roestvaststaal
Mechanical properties of stainless steel
Mechanische Eigenschaften Edelstahl
Propriétés mécaniques de l'acier inoxydable

Technische bijlagen

Technical Data

Technischen Daten

Données techniques

Austenitisch / Austenitic / Austenitisch / Austenitique

Werkstoff nr.	0,2% rek-grens N/mm ² min	1,0% rek-Grens N/mm ² min	trek-sterkte N/mm ²	breukrek (%) Lo = 5 Do langs min dwars min		kerfslagarbeid (ISO-V) J 20C langs min dwars min	
Material no.	0.2% elastic limit N/mm ² min	1.0% elastic Limit N/mm ² min	ult. tensile strength N/mm ²	strain at failure (%) Lo = 5 Do longit.min transv.min		notch impact load (ISO-V) J 20C longit.min transv.min	
Werkstoff nr.	0,2% Dehnungs-grenze N/mm ² min	1,0% Dehnungs-grenze N/mm ² min	Zugfestigkeit N/mm ²	Bruchdehnung (%) Lo = 5 Do längs min quer min		Kerbschlagarbeit (ISO-V) J 20C längs min quer min	
Matériau N°	Limite élast. 0,2 % N/mm ² min	Limite élast. 1.0% N/mm ² min	Résist. Traction N/mm ²	Déform. Rupture (%) Lo = 5 Do Min. longit. – Min. transv.		Force de choc – entaille (ISO-V) J 20C Min. longit. – Min. transv.	
1.4306	180	215	460 - 680	40	35	85	55
1.4307	180	215	460 - 480	40	35	85	55
1.4401	205	240	510 - 710	40	35	85	55
1.4404	190	225	490 - 690	40	35	85	55
1.4435	190	225	490 - 690	40	35	85	55
1.4462*	450	500	680 - 880	25	--	85	--
1.4541	200	235	500 - 730	35	30	85	55
1.4571	210	245	500 - 730	35	30	85	55

* 1.4462 is austenitisch / ferritisch / is austenitic / ferritic / ist austenitisch / ferritisch / austénitique et ferritique

Legerings-type	0,2% rek-grens N/mm ² min	1,0% rek-grens N/mm ² min	treksterkte N/mm ²	breukrek (%) Lo = 2" of 50 mm langs min dwars min		UNS
Alloy type	0.2% elastic limit N/mm ² min	1.0% elastic limit N/mm ² min	ult. tensile strength N/mm ²	strain at failure (%) Lo = 2" or 50 mm longit.min transv.min		UNS
Legierungstyp	0,2% Dehnungsgrenze N/mm ² min	1,0% Dehnungsgrenze N/mm ² min	Zugfestigkeit N/mm ²	Bruchdehnung (%) Lo = 2" oder 50 mm längs min quer min		UNS
Type d'acier	Lim, N/mm ² min	Limite élast. 1,0% N/mm ² min	Résist. Traction N/mm ²	Déform. Rupture(%) Lo = 2" ou 50 mm Min. longit. – Min. transv.		UNS
304L	170	–	485	35	25	S30403
304LN	205	–	515	35	25	S30453
316	205	–	515	35	25	S31600
316L	170	–	485	35	25	S31603
321	205	–	515	35	25	S32100
310	205	–	515	35	25	S31008/31009

De opgegeven breukrek geldt voor striptesten met wanddikten ≥ 7.94 mm en beproeving van volledige pijpstukken (kleine diameters). Voor de overige afmetingen wordt verwezen naar de ASTM standaard.

The quoted strain at failure applies to strip tests with wall thicknesses ≥ 7.94 mm and tests of complete pieces of pipe (small diameters). With regard to other dimensions, refer to the ASTM standard.

Die angegebene Bruchdehnung gilt für "Strip tests" mit Wandstärken $\geq 7,94$ mm und für die Prüfung vollständiger Rohrstücke (kleine Durchmesser). Andere Maße finden Sie unter der ASTM-Norm

La déformation à la rupture s'applique aux essais de traction $\geq 7,94$ mm et aux tests de pièces entières de tube (petits diamètres). Pour les autres dimensions, consultez la norme ASTM.

ASTM-EN-ISO toleranties
ASTM-EN-ISO tolerances
ASTM-EN-ISO Toleranzen
Tolérances ASTM-EN-ISO

Technische bijlagen

Technical Data

Technischen Daten

Données techniques

Tolerantie volgens EN ISO 1127 gelaste buis
Tolerances according to EN ISO 1127 welded pipe
Toleranzen nach EN ISO 1127 geschweisste Rohr nach
Tolérances conformément aux normes EN ISO 1127

uitwendige diameter ≤ 168,3 mm. outside diameter ≤ 168,3 mm. Aussendurchmesser ≤ 168,3 mm. Diamètre extérieur ≤ 168,3 mm.		wanddikte wall thickness Wanddicke Epaisseur de paroi	
Indeling Arrangement Einteilung Configuration	Tolerantie UD Tolerance OD Toleranzen AD Tolérances DE	Indeling Arrangement Einteilung Configuration	Toleranties Tolerances Toleranzen Tolérances
D0	± 2%	T0	± 20%
D1	± 1,5% min. ± 0,75 mm	T1	± 15% min. ± 0,6 mm
D2	± 1% min. ± 0,50 mm	T2	± 12,5 mm min. ± 0,40 mm
D3	± 0,75% min. ± 0,30 mm	T3	± 10% min. ± 0,20 mm
D4	± 0,50% min. ± 0,10 mm	T4	± 7,5% min. ± 0,15 mm

- * Afmetingen met een uitwendige diameter > 168,3 mm. ± 1,0% max. ± 3 mm.
- * Dimensions with an outside diameter > 168,3 mm. ± 1,0% max. ± 3 mm.
- * Abmessungen mit einem Aussendurchmesser > 168,3 mm. ± 1,0% max. ± 3 mm.
- * Dimensions avec un diamètre extérieur > 168,3 mm. ± 1,0% max. ± 3 mm.

Rechtheid
Straightness
Geradheit
Rectitude



Meetplaat
 Measureplate
 Messplatte
 Plaque mesure

Buis buiten diameter Outside diameter Rohr-Aussendurchmesser Diamètre extérieur	Toelaatbare afwijking op de rechtheid Allowable deviation straightness Zulässige Abweichung von der Geraden Ecart admis par rapport à la rectitude
tot - till - bis - jusque 17,2	
over - over - über - plus de 17,2	
tot - till - bis - jusque 133	2
over - over - über - plus de 114,3	2,5

Toleranties volgens ASTM A 269

Tolerances according to ASTM A 269

Toleranzas nach ASTM A 269

Tolérances selon la norme ASTM A 269

Buitendiameter Outside pipe diameter Aussendurchmesser Diamètre extérieur du tube		Wanddikte Wall thickness Wanddicke Epaisseur de paroi	
Nominale buitendiameter Nominal outside pipe diameter Nominale Aussendurchmesser Diamètre extérieur nominal du tube	Toegestane afwijkingen Allowable deviation Zugelassene Abweichungen Ecart admis	Toegestane afwijkingen Allowable deviation Zugelassene Abweichungen Ecart admis	
inches (mm)	inches (mm)		
< 1/2"	± 0.005" (0.13)"		
≥ 1/2" <1.1/2" (12.7 - 38.1)	± 0.005" (0.13)"		
≥1.1/2" <3.1/2" (38.1 - 88.9)	± 0.010" (0.25)"		
≥3.1/2" <5.1/2" (88.9 - 139.7)	± 0.015" (0.38)"		
≥5.1/2" <8" (139.7 - 203.2)	± 0.030" (0.76)"		

Toleranties volgens ASTM A312 - A530 - A778 - A999

Tolerances according to ASTM A312 - A530 - A778 - A999

Toleranzas nach ASTM A312 - A530 - A778 - A999

Tolérances selon la norme ASTM A312 - A530 - A778 - A999

Buitendiameter Outside pipe diameter Aussendurchmesser Diamètre extérieur du tube		Wanddikte Wall thickness Wanddicke Epaisseur de paroi									
Nominale buitendiameter Nominal outside pipe diameter Nominale Aussendurchmesser Diamètre extérieur nominal du tube	Toegestane afwijkingen Allowable deviation Zugelassene Abweichungen Ecart admis	Toegestane afwijkingen Allowable deviation Zugelassene Abweichungen Ecart admis									
inches (mm)	inches (mm)										
1/8" ≤1.1/2" (10.29 - 48.26)	+0.015" (0.40)"	-0.031" (0.79)"	<table border="1"> <tr> <td>+ niet gespecificeerd</td> <td>-12.5%</td> </tr> <tr> <td>+ not specified</td> <td>-12.5%</td> </tr> <tr> <td>+ nicht spezifiziert</td> <td>-12.5%</td> </tr> <tr> <td>+ non spécifié</td> <td>-12.5%</td> </tr> </table>	+ niet gespecificeerd	-12.5%	+ not specified	-12.5%	+ nicht spezifiziert	-12.5%	+ non spécifié	-12.5%
+ niet gespecificeerd	-12.5%										
+ not specified	-12.5%										
+ nicht spezifiziert	-12.5%										
+ non spécifié	-12.5%										
>1.1/2" ≤4" (48.26 - 114.30)	+0.031" (0.79)"	-0.031" (0.79)"									
>4" ≤8" (114.30 - 219.08)	+0.062" (1.59)"	-0.031" (0.79)"									
>8" ≤18" (219.08 - 457.2)	+0.093" (2.38)"	-0.031" (0.79)"									
>18" ≤26" (457.2 - 660.4)	+0.125" (3.18)"	-0.031" (0.79)"									
>26" ≤34" (660.4 - 863.6)	+0.156" (3.97)"	-0.031" (0.79)"									
>34" ≤48" (863.6 - 1219.2)	+0.187" (4.76)"	-0.031" (0.79)"									

**Tabel voor druk en temperatuur t.b.v. roestvaststalen buis
wrkst. 1.4301 (AISI 304)**
**Table for pressure and temperature for stainless steel pipes
werkstoff 1.4301 (AISI 304)**
**Druck-Temperatur Tabelle für Legierungstypen
Wrkst. 1.4301 (AISI 304)**
**Tableau de pression et de température pour tubes en acier
inoxydable 1.4301 (AISI 304)**

Formule:

Formula:

Formel:

Formule:

T = < 120°C

T = > 120°C

$$P = \frac{20 \cdot sZUL \cdot Vn \cdot Sv}{Da}$$

$$P = \frac{20 \cdot sZUL \cdot Vn \cdot Sv}{Di + (Vn \cdot Sv)}$$

Deze formule is alleen toepasbaar bij constante bedrijfstemperaturen

This formula is only applicable at constant operational temperatures

Diese Formel ist nur anwendbar bei konstante Betriebstemperaturen

Cette formule est uniquement applicable à des températures constantes de fonctionnement

Formule volgens DIN 2413 voor WR 1.4301

Formula according to DIN 2413 for WR 1.4301

Formel nach DIN 2413 für WR 1.4301

Formule selon la norme DIN 2413 pour WR 1.4301

- P = maximale inwendige druk in bar / maximum internal pressure in bar / maximale Innendruck in Bar / pression intérieure maximale en bars
 Da = uitwendige pijpdiameter in mm / outside pipe diameter in mm / Aussendurchmesser in mm / diamètre extérieur du tube en mm
 Di = inwendige pijpdiameter in mm / inside pipe diameter in mm / Innendurchmesser in mm / diamètre intérieur du tube en mm
 Sv = minimale pijpwanddikte (incl. minus tolerantie van 12,5% (T2) / minimal pipe wall thickness (including minus tolerance of 12.5% (T2) / minimale Wanddicke (einschliesslich minus Toleranz von 12,5% (T2) / épaisseur de paroi minimale (moins tolérance de 12,5% (T2).
 Vn = lasfactor = 1,0 / welding factors = 1.0 / Schweißfaktor = 1 / Facteurs de soudage = 1,0
 sZUL = toegestane spanning N/mm² gebaseerd op de 1% rekgrens volgens DIN 17458 met een veiligheidsfactor van 1,5 / minimum allowed pressure N/mm² based on the 1% yield strength according to DIN 17458 with a safety factor of 1.5 / Erlaubte Spannung N/mm² basiert auf 1% Streckgrenze nach Din 17458 mit Sicherheitsfaktor 1.5
 Tension admise en N/mm² sur la base d'une limite d'élasticité de 1 % selon la norme DIN 17458 avec un facteur de sécurité de 1,5

Omrekeningsfactoren drukgrenzen naar legeringstype, afgeleid van DIN 17458 tabel 4**Conversion factor pressure border in depending of alloy type, derived from DIN 17458 table 4****Umrechnungsfaktoren Druckgrenzen nach Legierungstypen, abgeleitet von DIN 17.458 Tabelle 4****Facteurs de conversion en fonction du type d'acier, selon le tableau 4 de la norme DIN 17458**

Wr.	AISI	20C	100C	150C	200C	250C	300C	350C	400C
1.4301	304	1,00	1,00	1,00	1,00	1,00	1,00	1,00	1,00
1.4306	304L	0,93	0,95	0,94	0,94	0,94	0,94	0,94	0,93
1.4307	304L	0,93	0,95	0,94	0,94	0,94	0,94	0,94	0,93
1.4401	316	1,04	1,10	1,11	1,13	1,15	1,16	1,16	1,15
1.4436	316	1,04	1,10	1,11	1,13	1,15	1,16	1,16	1,15
1.4404	316L	0,98	1,04	1,05	1,06	1,08	1,07	1,08	1,08
1.4435	316L	0,98	1,04	1,05	1,06	1,08	1,07	1,08	1,08
1.4541	321	1,02	1,09	1,13	1,18	1,21	1,24	1,25	1,25

Waarden hebben betrekking op WR 1.4301 (AISI 304).

Op blz. 141 vindt u de omrekeningsfactoren voor andere soorten roestvaststaal.

Values are related to material AISI 304.

Please find conversion factors for other stainless steel types on page 141.

Werten beziehen sich auf WR 1.4301 (AISI 304).

Auf Seite 141 finden Sie die Umrechnungsfaktoren für anderen Edlstahlsorten.

Les valeurs concernent le matériau AISI 304.

Vous trouverez les facteurs de conversion relatifs à d'autres types d'acier inoxydable à la page 141.

UD	x	S	kg/m	ID	20°C	100°C	150°C	200°C	250°C	300°C	350°C	400°C
6,00	x	1,00	0,125	4,00	447	412	376	371	347	323	309	299
6,00	x	1,50	0,169	3,00	698	671	637	588	557	548	523	507
6,00	x	2,00	0,200	2,00	1070	977	902	894	840	803	778	743
6,30	x	0,89	0,121	4,52	379	337	315	308	284	265	253	245
6,30	x	1,24	0,157	3,82	528	507	463	439	428	398	380	369
6,35	x	0,51	0,075	5,33	216	179	177	162	149	139	133	129
6,35	x	0,71	0,100	4,93	300	257	249	234	216	201	192	187
6,35	x	0,89	0,122	4,57	376	334	312	305	281	262	250	243
6,35	x	0,91	0,124	4,53	385	343	319	313	289	269	257	249
6,35	x	1,22	0,157	3,91	516	492	449	428	415	386	369	357
6,35	x	1,24	0,159	3,87	524	502	458	435	423	394	377	365
6,35	x	1,63	0,193	3,09	724	689	661	611	572	568	543	526
6,35	x	1,65	0,194	3,05	737	697	673	621	579	578	553	535
6,35	x	2,03	0,220	2,29	1002	914	858	845	786	751	728	712
7,00	x	0,95	0,144	5,10	364	321	302	293	271	252	241	234
7,00	x	1,00	0,150	5,00	383	342	318	312	288	268	256	248
7,00	x	1,50	0,207	4,00	575	567	517	478	478	445	425	412
7,20	x	0,45	0,076	6,30	168	139	135	123	114	106	101	98
8,00	x	0,50	0,094	7,00	168	139	135	123	114	106	101	98
8,00	x	0,75	0,136	6,50	252	210	209	192	177	165	158	153
8,00	x	1,00	0,175	6,00	335	292	279	266	246	229	219	212
8,00	x	1,50	0,244	5,00	503	477	435	418	402	374	358	347
8,00	x	2,00	0,300	4,00	698	671	637	588	557	548	523	507
8,00	x	2,50	0,344	3,00	967	883	839	815	759	725	703	696
8,50	x	0,50	0,100	7,50	158	131	126	115	107	99	95	92
9,00	x	0,75	0,155	7,50	224	186	185	168	156	145	138	134
9,00	x	1,00	0,200	7,00	298	255	248	233	215	200	191	185
9,00	x	1,50	0,282	6,00	447	412	376	371	347	323	309	299
9,50	x	0,89	0,192	7,72	251	210	209	192	177	165	158	153
9,50	x	1,24	0,256	7,02	350	307	291	280	259	241	230	223
9,53	x	0,51	0,115	8,51	144	119	114	104	96	90	86	83
9,53	x	0,71	0,157	8,11	200	166	163	149	138	128	122	119
9,53	x	0,89	0,193	7,75	251	209	208	191	177	164	157	152
9,53	x	1,24	0,257	7,05	349	306	290	279	258	240	229	222
9,53	x	1,65	0,326	6,23	465	431	394	386	364	339	324	314

UD	x	S	kg/m	ID	20°C	100°C	150°C	200°C	250°C	300°C	350°C	400°C
9,53	x	2,03	0,381	5,47	572	562	513	475	474	441	422	409
9,53	x	3,18	0,506	3,17	1072	979	904	895	841	804	779	744
10,00	x	0,50	0,119	9,00	134	111	106	97	90	83	80	77
10,00	x	1,00	0,225	8,00	268	226	223	206	191	177	170	164
10,00	x	1,50	0,319	7,00	403	362	334	331	305	284	272	263
10,00	x	1,60	0,337	6,80	429	392	357	357	330	307	294	285
10,00	x	2,00	0,401	6,00	537	518	473	446	437	406	388	376
10,00	x	2,50	0,470	5,00	698	671	637	588	557	548	523	507
10,20	x	1,00	0,230	8,20	263	221	218	202	186	174	166	161
10,20	x	1,20	0,270	7,80	316	272	262	248	229	214	204	198
10,20	x	1,60	0,345	7,00	421	382	350	349	322	300	287	278
10,20	x	2,00	0,411	6,20	526	505	461	437	426	396	379	367
10,20	x	2,60	0,495	5,00	717	684	655	605	568	563	538	521
10,29	x	1,24	0,281	7,81	323	280	269	255	236	220	210	203
10,29	x	1,73	0,371	6,83	451	416	380	375	351	327	312	302
10,29	x	2,41	0,476	5,47	638	628	582	538	522	501	479	464
11,00	x	0,75	0,192	9,50	183	152	148	135	125	116	111	108
11,00	x	1,00	0,250	9,00	244	203	203	185	171	159	152	148
11,00	x	1,50	0,357	8,00	366	323	304	295	272	254	242	235
11,00	x	2,00	0,451	7,00	488	459	419	405	387	360	340	333
11,60	x	1,75	0,432	8,10	405	365	336	333	307	286	273	265
12,00	x	0,50	0,144	11,00	112	93	88	80	74	69	66	64
12,00	x	1,00	0,275	10,00	224	186	185	168	156	145	138	134
12,00	x	1,50	0,394	9,00	335	292	279	266	246	229	219	212
12,00	x	2,00	0,501	8,00	447	412	376	371	347	323	309	299
12,00	x	2,50	0,595	7,00	559	546	498	464	460	429	410	397
12,00	x	2,90	0,661	6,20	648	666	608	561	539	523	500	484
12,00	x	3,00	0,676	6,00	698	671	637	588	557	548	523	507
12,00	x	4,00	0,801	4,00	1070	977	902	894	840	803	778	743
12,50	x	1,00	0,288	10,50	215	178	176	161	149	138	132	128
12,70	x	0,51	0,156	11,68	108	89	84	77	71	66	63	61
12,70	x	0,71	0,213	11,28	150	125	120	109	101	94	90	87
12,70	x	0,89	0,263	10,92	188	156	153	139	129	120	114	111
12,70	x	0,91	0,269	10,88	192	160	156	143	132	123	117	114
12,70	x	1,22	0,351	10,26	258	216	214	197	182	170	162	157
12,70	x	1,24	0,356	10,22	262	220	218	201	186	173	165	160
12,70	x	1,63	0,452	9,44	344	301	286	275	254	236	226	219
12,70	x	1,65	0,457	9,40	349	305	290	279	257	240	229	222
12,70	x	2,03	0,542	8,64	429	391	357	356	330	307	293	284
12,70	x	3,18	0,758	6,34	700	672	638	590	558	549	525	508
13,00	x	1,00	0,300	11,00	206	171	169	154	142	133	127	123
13,00	x	1,50	0,432	10,00	310	266	257	243	224	209	200	193
13,00	x	2,50	0,657	8,00	516	492	449	429	415	387	369	358
13,25	x	2,75	0,723	7,75	557	543	496	462	458	426	408	395
13,50	x	1,60	0,477	10,30	318	274	264	250	231	215	206	199
13,50	x	1,80	0,527	9,90	358	315	297	287	265	247	236	229
13,50	x	2,00	0,576	9,50	398	357	330	326	301	280	268	259

UD	x	S	kg/m	ID	20°C	100°C	150°C	200°C	250°C	300°C	350°C	400°C
13,50	x	2,30	0,645	8,90	457	423	386	380	357	332	317	307
13,50	x	2,35	0,656	8,80	467	434	396	388	366	341	326	316
13,50	x	2,60	0,710	8,30	517	493	450	429	416	387	370	359
13,50	x	2,90	0,770	7,70	576	568	519	479	478	446	426	413
13,72	x	1,24	0,387	11,24	243	202	201	184	170	158	151	147
13,72	x	1,65	0,499	10,42	323	279	268	255	235	219	209	203
13,72	x	2,24	0,644	9,24	438	401	366	364	338	315	301	292
13,72	x	3,02	0,809	7,68	591	587	536	495	490	461	440	427
13,72	x	3,70	0,928	6,32	777	724	709	655	610	601	583	565
14,00	x	0,50	0,169	13,00	96	80	75	68	63	59	56	54
14,00	x	1,00	0,326	12,00	192	159	156	142	131	122	117	113
14,00	x	1,50	0,470	11,00	288	244	239	223	206	192	183	178
14,00	x	2,00	0,601	10,00	383	342	318	312	288	268	256	248
14,00	x	2,50	0,720	9,00	479	448	409	398	378	352	336	326
14,00	x	3,00	0,826	8,00	575	567	517	478	478	445	425	412
14,30	x	2,10	0,642	10,10	394	353	327	322	298	277	265	257
14,30	x	3,15	0,879	8,00	591	588	536	495	491	461	441	427
14,30	x	4,77	1,138	4,76	1071	978	903	895	841	804	779	743
14,60	x	2,25	0,696	10,10	414	374	343	341	315	294	281	272
15,00	x	1,00	0,351	13,00	179	149	145	132	122	114	108	105
15,00	x	1,20	0,415	12,60	215	178	176	161	149	138	132	128
15,00	x	1,50	0,507	12,00	268	226	223	206	191	177	170	164
15,00	x	2,00	0,651	11,00	358	315	297	287	265	247	236	229
15,00	x	2,50	0,783	10,00	447	412	376	371	347	323	309	299
15,00	x	3,00	0,901	9,00	537	518	473	446	437	406	388	376
15,00	x	4,00	1,102	7,00	764	716	698	644	600	594	573	556
15,88	x	0,71	0,270	14,46	120	100	94	86	80	74	71	69
15,88	x	0,89	0,334	14,10	150	125	120	110	101	94	90	87
15,88	x	0,91	0,341	14,06	154	128	123	112	104	96	92	89
15,88	x	1,22	0,448	13,44	206	171	169	154	142	132	127	123
15,88	x	1,24	0,455	13,40	210	174	172	157	145	135	129	125
15,88	x	1,63	0,582	12,62	275	233	229	213	196	183	175	169
15,88	x	1,65	0,588	12,58	279	236	232	216	199	185	177	172
15,88	x	2,03	0,704	11,82	343	300	285	273	253	235	225	218
16,00	x	1,00	0,376	14,00	168	139	135	123	114	106	101	98
16,00	x	1,50	0,545	13,00	252	210	209	192	177	165	158	153
16,00	x	1,80	0,640	12,40	302	258	251	236	218	203	194	188
16,00	x	2,00	0,701	12,00	335	292	279	266	246	229	219	212
16,00	x	2,50	0,845	11,00	419	380	348	347	321	299	285	276
16,00	x	3,00	0,977	10,00	503	477	435	418	402	374	358	347
16,00	x	3,20	1,026	9,60	537	518	473	446	437	406	388	376
16,00	x	3,50	1,096	9,00	587	582	531	491	487	457	437	423
16,00	x	4,00	1,202	8,00	698	671	637	588	557	548	523	507
17,00	x	1,00	0,401	15,00	158	131	126	115	107	99	95	92
17,00	x	1,50	0,582	14,00	237	197	197	179	166	154	147	143
17,00	x	2,00	0,751	13,00	316	272	262	248	229	214	204	198
17,00	x	2,50	0,908	12,00	395	354	328	323	298	278	265	257

UD	x	S	kg/m	ID	20°C	100°C	150°C	200°C	250°C	300°C	350°C	400°C
17,00	x	3,00	1,052	11,00	474	442	403	393	372	347	331	321
17,15	x	1,24	0,494	14,67	194	161	158	144	133	124	118	115
17,15	x	1,65	0,640	13,85	258	216	214	198	183	170	162	157
17,15	x	2,31	0,858	12,53	361	319	300	291	269	250	239	232
17,15	x	2,60	0,947	11,95	407	367	338	335	309	288	275	267
17,15	x	3,20	1,118	10,75	501	474	433	416	400	372	355	344
17,20	x	1,50	0,590	14,20	234	194	194	177	164	152	146	141
17,20	x	1,60	0,625	14,00	250	208	207	190	176	164	156	152
17,20	x	1,80	0,694	13,60	281	238	233	217	201	187	179	173
17,20	x	2,00	0,761	13,20	312	268	259	245	226	211	201	195
17,20	x	2,30	0,858	12,60	359	316	298	288	266	248	237	230
17,20	x	2,35	0,874	12,50	367	324	304	296	273	254	243	235
17,20	x	2,60	0,951	12,00	406	365	337	334	308	287	274	266
17,20	x	2,90	1,038	11,40	452	418	381	376	352	328	313	303
17,20	x	3,20	1,122	10,80	499	472	431	415	398	371	354	343
17,30	x	2,50	0,926	12,30	388	346	322	316	292	272	260	252
18,00	x	1,00	0,426	16,00	149	124	119	109	100	93	89	86
18,00	x	1,50	0,620	15,00	224	186	185	168	156	145	138	134
18,00	x	1,60	0,657	14,80	239	198	198	181	167	156	149	144
18,00	x	2,00	0,801	14,00	298	255	248	233	215	200	191	185
18,00	x	2,50	0,970	13,00	373	330	309	302	278	259	248	240
18,00	x	3,00	1,127	12,00	447	412	376	371	347	323	309	299
18,00	x	3,50	1,271	11,00	522	499	456	433	421	392	375	363
18,00	x	4,00	1,402	10,00	596	595	543	501	495	467	446	432
18,00	x	5,00	1,628	8,00	811	745	740	684	636	619	608	589
19,00	x	1,50	0,657	16,00	212	176	174	159	147	136	130	126
19,00	x	2,00	0,851	15,00	282	240	235	219	202	188	180	174
19,05	x	0,89	0,405	17,27	125	104	99	90	83	78	74	72
19,05	x	0,91	0,413	17,23	128	106	101	92	85	80	76	74
19,05	x	1,00	0,452	17,05	141	117	112	102	94	88	84	81
19,05	x	1,22	0,545	16,61	172	143	138	126	117	109	104	101
19,05	x	1,24	0,553	16,57	175	145	141	129	119	111	106	102
19,05	x	1,63	0,711	15,79	230	191	190	173	160	149	142	138
19,05	x	1,65	0,719	15,75	232	193	193	176	162	151	144	140
19,05	x	2,03	0,865	14,99	286	243	237	222	205	191	182	177
19,05	x	2,10	0,891	14,85	296	253	246	231	213	198	189	184
19,05	x	2,11	0,895	14,83	297	254	247	232	214	199	190	185
19,05	x	3,25	1,286	12,55	458	424	387	380	357	333	318	308
19,50	x	1,24	0,567	17,02	171	142	137	125	116	108	103	100
20,00	x	1,00	0,476	18,00	134	111	106	97	90	83	80	77
20,00	x	1,25	0,587	17,50	168	139	135	123	114	106	101	98
20,00	x	1,50	0,695	17,00	201	167	164	150	139	129	123	119
20,00	x	2,00	0,901	16,00	268	226	223	206	191	177	170	164
20,00	x	2,50	1,096	15,00	335	292	279	266	246	229	219	212
20,00	x	3,00	1,277	14,00	403	362	334	331	305	284	272	263
20,00	x	3,50	1,446	13,00	470	437	399	390	369	343	328	318
20,00	x	4,00	1,603	12,00	537	518	473	446	437	406	388	376

UD	x	S	kg/m	ID	20°C	100°C	150°C	200°C	250°C	300°C	350°C	400°C
20,00	x	5,00	1,878	10,00	698	671	637	588	557	548	523	507
20,00	x	6,00	2,103	8,00	909	829	805	766	713	682	669	660
21,00	x	1,50	0,732	18,00	192	159	156	142	131	122	117	113
21,00	x	3,00	1,352	15,00	383	342	318	312	288	268	256	248
21,30	x	1,60	0,789	18,10	202	167	165	150	139	129	123	120
21,30	x	1,80	0,879	17,70	227	188	187	171	158	147	141	136
21,30	x	2,00	0,967	17,30	252	211	209	192	178	165	158	153
21,30	x	2,60	1,217	16,10	328	284	272	259	239	223	213	206
21,30	x	2,65	1,238	16,00	334	290	277	265	245	228	218	211
21,30	x	2,90	1,336	15,50	365	323	303	294	272	253	242	234
21,30	x	3,20	1,450	14,90	403	363	335	331	306	285	272	264
21,34	x	1,65	0,814	18,04	207	172	170	155	143	133	127	124
21,34	x	2,11	1,016	17,12	265	223	220	204	188	175	167	162
21,34	x	2,77	1,288	15,80	348	305	289	278	257	239	229	222
21,34	x	3,73	1,645	13,88	469	437	399	389	368	343	327	317
21,34	x	4,75	1,973	11,84	597	596	544	502	496	468	447	433
21,34	x	4,78	1,982	11,78	601	601	548	507	499	472	451	437
21,34	x	7,47	2,594	6,4	1159	1058	977	939	909	869	842	780
22,00	x	1,00	0,526	20,00	122	101	96	88	81	75	72	70
22,00	x	1,25	0,649	19,50	152	127	122	111	103	96	91	89
22,00	x	1,50	0,770	19,00	183	152	148	135	125	116	111	108
22,00	x	2,00	1,002	18,00	244	203	203	185	171	159	152	148
22,00	x	2,50	1,221	17,00	305	261	253	239	220	205	196	190
22,00	x	3,00	1,427	16,00	366	323	304	295	272	254	242	235
22,00	x	4,00	1,803	14,00	488	459	419	405	387	360	344	333
22,00	x	5,00	2,128	12,00	613	610	559	517	506	481	460	445
22,00	x	6,00	2,404	10,00	790	732	721	666	620	608	592	574
23,00	x	1,50	0,808	20,00	175	145	141	129	119	111	106	103
23,30	x	3,50	1,735	16,30	403	363	335	331	306	285	272	264
23,60	x	3,75	1,864	16,10	426	388	354	354	327	305	291	282
24,00	x	1,00	0,576	22,00	112	93	88	80	74	69	66	64
24,00	x	1,50	0,845	21,00	168	139	135	123	114	106	101	98
24,00	x	2,00	1,102	20,00	224	186	185	168	156	145	138	134
24,00	x	3,00	1,578	18,00	335	292	279	266	246	229	219	212
24,00	x	3,50	1,797	17,00	391	350	325	320	295	275	263	254
24,00	x	4,00	2,003	16,00	447	412	376	371	347	323	309	299
24,00	x	7,00	2,980	10,00	871	795	734	684	653	783	650	633
25,00	x	1,00	0,601	23,00	107	89	84	77	71	66	63	61
25,00	x	1,50	0,883	22,00	161	134	129	118	109	101	97	94
25,00	x	2,00	1,152	21,00	215	178	176	161	149	138	132	128
25,00	x	2,30	1,307	20,40	247	206	205	188	174	162	154	150
25,00	x	2,50	1,409	20,00	268	226	223	206	191	177	170	164
25,00	x	3,00	1,653	19,00	322	278	267	254	235	218	209	202
25,00	x	3,20	1,747	18,60	343	300	285	274	253	236	225	218
25,00	x	3,50	1,884	18,00	376	333	312	304	281	262	250	242
25,00	x	4,00	2,103	17,00	429	392	357	357	330	307	294	285
25,00	x	5,00	2,504	15,00	537	518	473	446	437	406	388	376

UD	x	S	kg/m	ID	20°C	100°C	150°C	200°C	250°C	300°C	350°C	400°C
25,00	x	6,00	2,855	13,00	660	644	602	556	535	518	495	479
25,40	x	0,91	0,558	23,58	96	80	75	68	63	59	56	54
25,40	x	1,25	0,756	22,90	132	110	105	95	88	82	78	76
25,40	x	1,63	0,970	22,14	172	143	139	127	117	109	104	101
25,40	x	1,65	0,981	22,10	174	145	141	128	119	110	105	102
25,40	x	2,11	1,229	21,18	223	185	184	168	155	144	138	133
26,00	x	3,00	1,728	20,00	310	266	257	243	224	209	200	193
26,67	x	1,65	1,034	23,37	166	138	133	122	112	105	100	97
26,67	x	2,11	1,298	22,45	212	176	174	159	147	137	131	127
26,67	x	2,87	1,710	20,93	289	246	240	224	207	193	184	179
26,67	x	3,91	2,228	18,85	393	352	327	322	297	277	264	256
26,67	x	4,50	2,498	17,67	453	418	381	376	352	328	313	304
26,67	x	5,53	2,927	15,61	556	543	495	462	457	426	407	394
26,67	x	5,54	2,931	15,59	557	544	497	463	459	427	408	395
26,67	x	5,56	2,939	15,55	559	547	499	465	461	429	410	397
26,67	x	7,82	3,691	11,03	878	801	787	740	689	659	653	638
26,90	x	1,60	1,014	23,70	160	133	128	117	108	100	96	93
26,90	x	2,00	1,247	22,90	200	166	163	149	137	128	122	118
26,90	x	2,30	1,417	22,30	229	191	190	173	160	149	142	138
26,90	x	2,60	1,582	21,70	259	218	215	199	183	171	163	158
26,90	x	2,65	1,609	21,60	264	222	220	203	187	174	167	162
26,90	x	2,90	1,743	21,10	289	246	240	225	208	193	185	179
26,90	x	3,20	1,899	20,50	319	276	265	252	232	216	207	200
26,90	x	3,60	2,100	19,70	359	316	298	289	267	248	237	230
26,90	x	4,00	2,294	18,90	399	358	331	327	302	281	269	260
27,00	x	1,00	0,651	25,00	99	83	78	71	65	61	58	56
27,00	x	3,00	1,803	21,00	298	255	248	233	215	200	191	185
27,00	x	3,50	2,060	20,00	348	305	289	278	257	239	228	221
27,00	x	4,00	2,304	19,00	398	357	330	326	301	280	268	259
28,00	x	1,00	0,676	26,00	96	80	75	68	63	59	56	54
28,00	x	1,50	0,995	25,00	144	119	114	104	96	90	86	83
28,00	x	2,00	1,302	24,00	192	159	156	142	131	122	117	113
28,00	x	2,50	1,596	23,00	240	199	199	182	168	156	149	145
28,00	x	3,00	1,878	22,00	288	244	239	223	206	192	183	178
28,00	x	3,50	2,147	21,00	335	292	279	266	246	229	219	212
28,00	x	4,00	2,404	20,00	383	342	318	312	288	268	256	248
28,00	x	5,00	2,880	18,00	479	448	409	398	378	352	336	326
29,00	x	2,00	1,352	25,00	185	154	150	137	126	118	113	109
30,00	x	1,00	0,726	28,00	89	74	69	63	59	55	52	51
30,00	x	1,25	0,900	27,50	112	93	88	80	74	69	66	64
30,00	x	1,50	1,070	27,00	134	111	106	97	90	83	80	77
30,00	x	2,00	1,402	26,00	179	149	145	132	122	114	108	105
30,00	x	2,30	1,595	25,40	206	171	168	154	142	132	126	122
30,00	x	2,50	1,722	25,00	224	186	185	168	156	145	138	134
30,00	x	2,60	1,784	24,80	233	193	193	176	162	151	145	140
30,00	x	3,00	2,028	24,00	268	226	223	206	191	177	170	164
30,00	x	3,50	2,322	23,00	313	269	260	246	227	212	202	196

UD	x	S	kg/m	ID	20°C	100°C	150°C	200°C	250°C	300°C	350°C	400°C
30,00	x	4,00	2,604	22,00	358	315	297	287	265	247	236	229
30,00	x	5,00	3,130	20,00	447	412	376	371	347	323	309	299
31,00	x	4,00	2,704	23,00	346	303	288	276	255	238	227	220
31,75	x	1,63	1,229	28,49	138	114	109	100	92	86	82	79
31,80	x	1,00	0,771	29,80	84	70	65	60	55	51	49	48
31,80	x	1,25	0,956	29,30	105	88	83	75	70	65	62	60
31,80	x	1,60	1,210	28,60	135	112	107	98	90	84	80	78
32,00	x	1,00	0,776	30,00	84	70	65	59	55	51	49	47
32,00	x	1,25	0,962	29,50	105	87	82	75	69	64	61	60
32,00	x	1,50	1,146	29,00	126	104	99	91	84	78	74	72
32,00	x	2,00	1,502	28,00	168	139	135	123	114	106	101	98
32,00	x	2,50	1,847	27,00	210	174	172	157	145	135	129	125
32,00	x	3,00	2,178	26,00	252	210	209	192	177	165	158	153
32,00	x	3,50	2,498	25,00	293	250	244	228	211	196	188	182
32,00	x	4,00	2,804	24,00	335	292	279	266	246	229	219	212
33,00	x	1,50	1,183	30,00	122	101	96	88	81	75	72	70
33,00	x	2,50	1,909	28,00	203	169	166	152	140	130	125	121
33,00	x	4,00	2,905	25,00	325	282	270	257	237	221	211	205
33,00	x	7,25	4,675	18,50	590	490	586	535	494	460	439	426
33,40	x	1,65	1,312	30,10	133	110	105	96	88	82	79	76
33,40	x	2,77	2,125	27,86	223	185	184	168	155	144	138	133
33,40	x	3,38	2,541	26,64	272	229	226	209	193	180	172	167
33,40	x	4,55	3,287	24,30	366	323	304	295	272	253	242	235
33,40	x	6,35	4,301	20,70	510	485	443	424	409	381	364	353
33,40	x	9,09	5,533	15,22	787	730	718	664	618	606	590	572
33,70	x	1,60	1,286	30,50	127	106	101	92	85	79	75	73
33,70	x	2,00	1,588	29,70	159	132	128	116	108	100	96	93
33,70	x	2,30	1,808	29,10	183	152	148	135	125	116	111	108
33,70	x	2,60	2,025	28,50	207	172	170	155	143	133	127	123
33,70	x	2,65	2,060	28,40	211	175	173	158	146	136	130	126
33,70	x	2,90	2,237	27,90	231	192	191	175	161	150	143	139
33,70	x	3,20	2,444	27,30	255	213	212	195	180	167	160	155
33,70	x	3,25	2,478	27,20	259	217	215	198	183	170	163	158
33,70	x	3,60	2,713	26,50	287	244	238	222	205	191	183	177
33,70	x	4,00	2,975	25,70	318	275	264	251	232	216	206	200
33,70	x	4,05	3,007	25,60	322	279	268	255	235	219	209	203
34,00	x	1,00	0,826	32,00	79	66	61	56	51	48	46	44
34,00	x	1,50	1,221	31,00	118	98	93	85	79	73	70	68
34,00	x	2,00	1,603	30,00	158	131	126	115	107	99	95	92
34,00	x	3,50	2,673	27,00	276	234	229	213	197	183	175	170
34,00	x	4,00	3,005	26,00	316	272	262	248	229	214	204	198
34,00	x	5,00	3,631	24,00	395	354	328	323	298	278	265	257
34,00	x	5,50	3,925	23,00	434	397	362	360	335	311	298	288
34,00	x	1,25	1,025	31,50	99	82	77	70	65	60	58	56
35,00	x	1,50	1,258	32,00	115	96	90	82	76	71	68	66
35,00	x	2,00	1,653	31,00	153	127	123	112	103	96	92	89
35,00	x	2,50	2,035	30,00	192	159	156	142	131	122	117	113

UD	x	S	kg/m	ID	20°C	100°C	150°C	200°C	250°C	300°C	350°C	400°C
35,00	x	4,00	3,105	27,00	307	263	255	240	222	207	197	191
35,00	x	5,00	3,756	25,00	383	342	318	312	288	268	256	248
36,00	x	1,00	0,876	34,00	75	62	58	53	49	45	43	42
36,00	x	2,00	1,703	32,00	149	124	119	109	100	93	89	86
36,00	x	3,00	2,479	30,00	224	186	185	168	156	145	138	134
36,00	x	6,00	4,507	24,00	447	412	376	371	347	323	309	299
37,80	x	5,22	4,258	27,36	371	328	308	299	277	258	246	238
38,00	x	1,00	0,926	36,00	71	59	54	50	46	43	41	40
38,00	x	1,25	1,150	35,50	88	73	69	63	58	54	51	50
38,00	x	1,50	1,371	35,00	106	88	83	76	70	65	62	60
38,00	x	2,00	1,803	34,00	141	117	112	102	95	88	84	82
38,00	x	2,50	2,222	33,00	177	147	143	130	120	112	107	104
38,00	x	2,60	2,305	32,80	184	152	149	136	125	117	112	108
38,00	x	3,00	2,629	32,00	212	176	174	159	147	136	130	126
38,00	x	3,60	3,101	30,80	254	213	211	194	179	167	160	155
38,00	x	4,00	3,405	30,00	282	240	235	219	202	188	180	174
38,00	x	5,00	4,132	28,00	353	310	293	283	261	243	232	225
38,00	x	6,00	4,808	26,00	424	385	352	352	325	302	289	280
38,10	x	1,25	1,153	35,60	88	73	68	62	58	54	51	50
38,10	x	1,50	1,375	35,10	106	88	83	75	70	65	62	60
38,10	x	1,60	1,462	34,90	113	94	88	81	75	69	66	64
38,10	x	1,63	1,489	34,84	115	95	90	82	76	71	68	66
38,10	x	2,00	1,808	34,10	141	117	112	102	94	88	84	81
40,00	x	1,00	0,977	38,00	67	56	52	47	44	41	39	38
40,00	x	1,50	1,446	37,00	101	84	79	72	66	62	59	57
40,00	x	2,00	1,903	36,00	134	111	106	97	90	83	80	77
40,00	x	2,50	2,348	35,00	168	139	135	123	114	106	101	98
40,00	x	3,00	2,779	34,00	201	167	164	150	139	129	123	119
40,00	x	4,00	3,606	32,00	268	226	223	206	191	177	170	164
40,00	x	5,00	4,382	30,00	335	292	279	266	246	229	219	212
40,00	x	7,00	5,784	26,00	470	437	399	390	369	343	328	318
41,00	x	1,00	1,002	39,00	65	54	50	46	42	39	38	37
41,00	x	4,00	3,706	33,00	362	220	217	201	185	173	165	160
42,00	x	2,00	2,003	38,00	128	106	101	92	85	79	76	73
42,00	x	3,00	2,930	36,00	192	159	156	142	131	122	117	113
42,00	x	5,00	4,632	32,00	319	276	265	252	233	216	207	200
42,00	x	6,00	5,409	30,00	383	432	318	312	288	268	256	248
42,16	x	1,65	1,674	38,86	105	87	82	75	69	64	62	60
42,16	x	2,11	2,116	37,94	134	112	106	97	90	84	80	77
42,16	x	2,77	2,732	36,62	176	146	142	130	120	112	107	103
42,16	x	3,56	3,441	35,04	227	188	187	171	158	147	140	136
42,16	x	4,85	4,531	32,46	309	265	256	242	224	208	199	193
42,16	x	6,35	5,694	29,46	404	364	336	332	307	286	273	264
42,16	x	9,70	7,884	22,76	623	617	569	525	513	489	467	453
42,40	x	1,60	1,635	39,20	101	84	79	72	67	62	59	57
42,40	x	2,00	2,023	38,40	127	105	100	91	84	78	75	73
42,40	x	2,60	2,591	37,20	165	137	132	121	111	104	99	96

UD	x	S	kg/m	ID	20°C	100°C	150°C	200°C	250°C	300°C	350°C	400°C
42,40	x	2,65	2,638	37,10	168	139	135	123	114	106	101	98
42,40	x	2,90	2,868	36,60	184	152	149	136	125	117	112	108
42,40	x	3,20	3,141	36,00	203	168	165	151	140	130	124	120
42,40	x	3,25	3,186	35,90	206	171	168	154	142	132	126	122
42,40	x	3,60	3,498	35,20	228	189	188	172	159	148	141	137
42,40	x	4,00	3,846	34,40	253	212	210	193	179	166	159	154
42,40	x	4,05	3,889	34,30	256	215	213	196	181	169	161	156
42,40	x	6,30	5,695	29,80	399	358	341	327	302	281	269	260
42,40	x	6,35	5,732	29,70	402	361	334	330	305	284	271	263
43,00	x	1,50	1,559	40,00	94	78	73	67	61	57	55	53
43,00	x	5,50	5,165	32,00	343	300	285	274	253	235	225	218
44,00	x	2,00	2,103	40,00	122	101	96	88	81	75	72	70
44,00	x	3,00	3,080	38,00	183	152	148	135	125	116	111	108
44,50	x	1,50	1,615	41,50	90	75	70	64	59	55	53	51
44,50	x	1,60	1,719	41,30	96	80	75	69	63	59	56	55
44,50	x	2,00	2,128	40,50	121	100	95	87	80	75	71	69
44,50	x	2,30	2,430	39,90	139	115	110	101	93	86	83	80
44,50	x	2,50	2,629	39,50	151	125	120	110	101	94	90	87
44,50	x	2,60	2,728	39,30	157	130	125	115	106	98	94	91
44,50	x	2,65	2,777	39,20	160	133	128	117	108	101	96	93
44,50	x	2,90	3,021	38,70	175	145	141	129	119	111	106	103
44,50	x	3,00	3,117	38,50	181	150	146	134	123	115	110	106
44,50	x	3,20	3,309	38,10	193	160	157	143	132	123	118	114
44,50	x	4,00	4,056	36,50	241	201	200	183	169	158	151	146
44,50	x	5,50	5,371	33,50	332	288	275	263	243	226	216	209
45,00	x	1,00	1,102	43,00	60	50	46	42	39	36	34	33
45,00	x	1,50	1,634	42,00	89	74	69	63	59	55	52	51
45,00	x	2,00	2,153	41,00	119	99	94	86	79	74	70	68
45,00	x	3,50	3,637	38,00	209	173	171	156	144	134	128	124
45,00	x	4,00	4,107	37,00	239	198	198	181	167	156	149	144
45,00	x	5,00	5,008	35,00	298	255	248	233	215	200	191	185
48,00	x	2,50	2,848	43,00	140	116	111	101	94	87	83	81
48,00	x	4,00	4,407	40,00	224	186	185	168	156	145	138	134
48,26	x	1,65	1,926	44,96	92	76	71	65	60	56	54	52
48,26	x	2,77	3,155	42,72	154	128	123	112	104	97	92	89
48,26	x	3,68	4,108	40,90	205	170	167	153	141	131	126	122
48,26	x	5,08	5,493	38,10	282	235	240	219	202	188	180	174
48,26	x	7,14	7,352	33,98	397	330	356	325	300	280	267	259
48,26	x	10,15	9,686	27,96	564	553	505	469	466	434	415	402
48,26	x	10,16	9,693	27,94	565	554	505	469	467	434	415	402
48,30	x	1,50	1,758	45,30	83	69	65	59	54	51	48	47
48,30	x	1,60	1,871	45,10	89	74	69	63	58	54	52	50
48,30	x	1,65	1,927	45,00	92	76	71	65	60	56	53	52
48,30	x	2,00	2,319	44,30	111	92	87	80	73	68	65	63
48,30	x	2,30	2,649	43,70	128	106	101	92	85	79	76	73
48,30	x	2,50	2,867	43,30	139	115	110	101	93	87	83	80
48,30	x	2,60	2,975	43,10	144	120	115	105	97	90	86	84

UD	x	S	kg/m	ID	20°C	100°C	150°C	200°C	250°C	300°C	350°C	400°C
48,30	x	2,65	3,029	43,00	147	122	117	107	99	92	88	85
48,30	x	2,90	3,297	42,50	161	134	129	118	109	101	97	94
48,30	x	3,00	3,403	42,30	167	138	134	122	113	105	101	97
48,30	x	3,20	3,614	41,90	178	148	144	131	121	113	108	104
48,30	x	3,25	3,666	41,80	181	150	146	133	123	115	110	106
48,30	X	3,60	4,029	41,10	200	166	163	149	138	128	122	119
48,30	X	4,05	4,487	40,20	225	187	186	170	157	146	139	135
48,30	X	5,00	5,421	38,30	278	235	231	215	198	185	176	171
48,30	X	6,50	6,803	35,30	361	318	300	290	268	250	239	231
48,30	X	8,00	8,073	32,30	444	408	373	369	344	321	306	297
49,00	X	5,50	5,991	38,00	301	258	250	235	217	202	193	187
50,00	X	1,00	1,227	48,00	67	54	45	41	35	32	31	30
50,00	X	1,50	1,822	47,00	81	67	62	57	53	49	47	45
50,00	X	2,00	2,404	46,00	107	89	84	77	71	66	63	61
50,00	X	2,50	2,974	45,00	134	111	106	97	90	83	80	77
50,00	X	3,00	3,531	44,00	161	134	129	118	109	101	97	94
50,00	X	4,00	4,607	42,00	215	178	176	161	149	138	132	128
50,00	X	5,00	5,634	40,00	268	226	223	206	191	177	170	164
50,00	X	6,00	6,611	38,00	322	278	267	254	235	218	209	202
50,80	X	1,22	1,515	48,36	64	54	50	45	42	39	37	36
50,80	X	1,25	1,551	48,30	66	55	51	46	43	40	38	37
50,80	X	1,50	1,852	47,80	79	66	61	56	52	48	46	45
50,80	X	1,60	1,971	47,60	85	70	66	60	55	51	49	48
50,80	X	2,00	2,444	46,80	106	88	83	75	70	65	62	60
50,80	X	2,50	3,024	45,80	132	110	105	95	88	82	78	76
51,00	X	1,00	1,252	49,00	53	44	40	37	34	32	30	29
51,00	X	1,25	1,557	48,50	66	55	51	46	43	40	38	37
51,00	X	0,50	1,859	48,00	79	66	61	56	51	48	46	44
51,00	X	2,00	2,454	47,00	105	87	82	75	69	65	62	60
51,00	X	2,50	3,036	46,00	132	109	104	95	88	82	78	76
51,00	X	2,60	3,151	45,80	137	114	109	99	91	85	81	79
51,00	X	2,90	3,493	45,20	153	127	122	111	103	96	91	89
51,00	X	3,00	3,606	45,00	158	131	126	115	107	99	95	92
51,00	X	4,00	4,708	43,00	210	175	173	158	146	135	129	125
52,00	X	1,00	1,277	50,00	52	43	39	36	33	31	30	29
52,00	X	1,50	1,897	49,00	77	64	60	55	50	47	45	43
52,00	X	2,00	2,504	48,00	103	86	81	74	68	63	61	59
52,00	X	4,00	4,808	44,00	206	171	169	154	142	133	127	123
53,00	X	1,50	1,934	50,00	76	63	59	54	49	46	44	43
53,00	X	2,50	3,161	48,00	127	105	100	91	84	78	75	73
53,00	X	3,00	3,756	47,00	152	126	121	111	102	95	91	88
53,00	X	4,00	4,908	45,00	203	168	165	151	140	130	124	120
53,00	X	4,50	5,465	44,00	228	189	188	172	159	148	141	137
54,00	X	1,50	1,972	51,00	75	62	58	53	49	45	43	42
54,00	X	1,60	2,099	50,80	80	66	62	56	52	48	46	45
54,00	X	2,00	2,604	50,00	99	83	78	71	65	61	58	56
54,00	X	2,50	3,224	49,00	124	103	98	89	83	77	74	71

UD	x	S	kg/m	ID	20°C	100°C	150°C	200°C	250°C	300°C	350°C	400°C
54,00	X	3,00	3,831	48,00	149	124	119	109	100	93	89	86
54,00	X	6,30	7,525	41,40	313	269	260	246	227	212	202	196
55,00	X	2,00	2,654	51,00	98	81	76	69	64	60	57	55
55,00	X	2,50	3,287	50,00	122	101	96	88	81	75	72	70
55,00	X	5,00	6,260	45,00	244	203	203	185	171	159	152	148
56,00	X	3,00	3,981	50,00	144	119	114	104	96	90	86	83
57,00	X	1,50	2,085	54,00	71	59	54	50	46	43	41	40
57,00	x	2,00	2,754	53,00	94	78	73	67	62	58	55	53
57,00	X	2,30	3,150	52,40	108	90	85	77	72	67	64	62
57,00	X	2,50	3,412	52,00	118	98	93	85	78	73	69	67
57,00	X	2,60	3,542	51,80	122	102	96	88	81	76	72	70
57,00	X	2,90	3,929	51,20	137	113	108	99	91	85	81	79
57,00	X	3,00	4,056	51,00	141	117	112	102	95	88	84	82
57,00	X	3,50	4,689	50,00	165	137	132	121	112	104	99	96
57,00	X	4,00	5,308	49,00	188	156	153	140	129	120	115	111
57,00	X	4,50	5,916	48,00	212	176	174	159	147	136	130	126
57,00	X	5,00	6,510	47,00	235	195	195	178	165	153	146	142
57,00	X	6,30	7,998	44,40	297	253	246	231	214	199	190	184
57,00	X	6,50	8,219	44,00	306	263	254	240	221	206	197	191
57,00	X	8,00	9,816	41,00	377	334	313	305	282	263	251	243
58,00	X	2,60	3,607	52,80	120	100	95	86	80	74	71	69
60,00	X	1,00	1,477	58,00	45	37	34	31	29	27	26	25
60,00	X	2,50	3,600	55,00	112	93	88	80	74	69	66	64
60,00	X	5,00	6,886	50,00	224	186	185	168	156	145	138	134
60,00	X	6,00	8,113	48,00	268	226	223	206	191	177	170	164
60,30	X	1,50	2,209	57,30	67	55	51	47	43	40	39	37
60,30	X	1,60	2,352	57,10	71	59	55	50	46	43	41	40
60,30	x	2,00	2,920	56,30	89	74	69	63	58	54	52	50
60,30	X	2,30	3,340	55,70	102	85	80	73	67	63	60	58
60,30	X	2,50	3,618	55,30	111	92	87	80	74	68	65	63
60,30	X	2,60	3,757	55,10	116	96	91	83	77	71	68	66
60,30	x	2,65	3,825	55,00	118	98	93	85	78	73	70	67
60,30	x	2,90	4,168	54,50	129	107	102	93	86	80	77	74
60,30	x	3,00	4,304	54,30	133	111	106	97	89	83	79	77
60,30	x	3,20	4,575	53,90	142	118	113	103	95	89	85	82
60,30	x	3,25	4,643	53,80	145	120	115	105	97	90	86	84
60,30	x	3,60	5,111	53,10	160	133	128	117	108	101	96	93
60,30	x	3,65	5,178	53,00	162	135	130	119	110	102	98	95
60,30	x	4,00	5,639	52,30	178	148	144	131	121	113	108	105
60,30	x	4,50	6,288	51,30	200	166	163	149	138	128	123	119
60,30	x	5,00	6,924	50,30	222	185	184	168	155	144	138	133
60,30	x	7,10	9,458	46,10	316	272	262	249	230	214	204	198
60,30	x	7,62	10,052	45,06	339	296	282	270	249	232	222	215
60,30	x	8,00	10,477	44,30	356	313	296	286	264	246	235	227
60,30	x	10,00	12,595	40,30	445	409	373	370	345	321	307	297
60,33	x	1,65	2,424	57,03	73	61	57	52	48	44	42	41
60,33	x	2,77	3,992	54,79	123	102	97	89	82	76	73	71

UD	x	S	kg/m	ID	20°C	100°C	150°C	200°C	250°C	300°C	350°C	400°C
60,33	x	3,91	5,524	52,51	174	144	140	128	118	110	105	102
60,33	x	5,54	7,601	49,25	246	205	205	188	173	161	154	149
60,33	x	8,74	11,290	42,85	389	347	323	317	293	273	260	252
60,33	x	11,07	13,655	38,19	492	464	424	409	391	364	348	337
61,00	x	3,00	4,357	55,00	132	110	104	95	88	82	78	76
61,00	x	5,50	7,643	50,00	242	201	201	184	170	158	151	146
63,00	x	1,50	2,310	60,00	64	53	49	45	41	39	37	36
63,00	x	3,50	5,215	56,00	149	124	119	109	100	93	89	86
63,50	x	1,50	2,329	60,50	63	53	49	44	41	38	37	35
63,50	x	1,60	2,480	60,30	68	56	52	47	44	41	39	38
63,50	x	2,00	3,080	59,50	85	70	66	60	55	51	49	48
63,50	x	2,50	3,819	58,50	106	88	83	75	70	65	62	60
63,50	x	2,60	3,965	58,30	110	91	86	79	73	68	65	63
63,50	x	2,65	4,038	58,20	112	93	88	80	74	69	66	64
63,50	x	3,20	4,832	57,10	135	112	107	98	90	84	80	78
63,50	x	3,50	5,258	56,50	148	123	118	108	99	93	88	86
64,00	x	2,00	3,105	60,00	84	70	65	59	55	51	49	47
65,00	x	2,50	3,913	60,00	103	86	81	74	68	63	61	59
65,00	x	3,00	4,657	59,00	124	103	98	89	82	77	73	71
65,00	x	3,50	5,390	58,00	144	120	115	105	97	90	86	84
68,00	x	1,50	2,490	65,00	59	49	45	41	38	36	34	33
68,00	x	4,00	6,410	60,00	158	131	126	115	107	99	95	92
69,00	x	2,00	3,355	65,00	78	65	60	55	51	47	45	44
70,00	x	1,50	2,573	67,00	58	48	44	40	37	35	33	32
70,00	x	2,00	3,405	66,00	77	64	59	54	50	46	44	43
70,00	x	2,50	4,226	65,00	96	80	75	68	63	59	56	54
70,00	x	2,90	4,873	64,20	111	92	87	80	74	68	65	63
70,00	x	3,00	5,033	64,00	115	96	90	82	76	71	68	66
70,00	x	4,00	6,611	62,00	153	127	123	112	103	96	92	89
70,00	x	4,50	7,381	61,00	173	143	139	127	117	109	104	101
70,00	x	5,00	8,138	60,00	192	159	156	142	131	122	117	113
70,00	x	5,50	8,883	59,00	211	175	173	158	146	136	130	126
70,00	x	7,00	11,043	56,00	268	226	223	206	191	177	170	164
72,00	x	5,20	8,698	61,60	194	161	158	144	133	124	118	115
73,00	x	1,50	2,686	70,00	55	46	42	39	36	33	32	31
73,00	x	4,00	6,911	65,00	147	122	117	107	99	92	88	85
73,00	x	5,00	8,514	63,00	184	153	149	136	126	117	112	108
73,03	x	2,11	3,747	68,81	78	64	60	55	51	47	45	44
73,03	x	3,05	5,345	66,93	112	93	88	80	74	69	66	64
73,03	x	5,16	8,769	62,71	190	157	154	141	130	121	116	112
73,03	x	7,01	11,589	59,01	258	216	214	197	182	169	162	157
73,03	x	9,53	15,153	53,97	350	307	291	280	259	241	230	223
74,00	x	4,00	7,011	66,00	145	120	115	105	97	91	87	84
75,00	x	2,50	4,539	70,00	89	74	69	63	59	55	52	51
75,00	x	4,00	7,111	67,00	143	119	114	104	96	89	85	83
76,00	x	4,00	7,212	68,00	141	117	112	102	95	88	84	82
76,00	x	5,00	8,889	66,00	177	147	143	130	120	112	107	104

UD	x	S	kg/m	ID	20°C	100°C	150°C	200°C	250°C	300°C	350°C	400°C
76,00	x	5,50	9,709	65,00	194	161	158	144	133	124	119	115
76,00	x	6,00	10,517	64,00	212	176	174	159	147	136	130	126
76,10	x	1,50	2,802	73,10	53	44	40	37	34	32	30	29
76,10	x	1,60	2,985	72,90	56	47	43	39	36	34	32	31
76,10	x	1,65	3,076	72,80	58	48	45	41	38	35	33	32
76,10	x	2,00	3,711	72,10	71	59	54	50	46	43	41	39
76,10	x	2,30	4,250	71,50	81	67	63	57	53	49	47	46
76,10	x	2,50	4,607	71,10	88	73	68	62	58	54	51	50
76,10	x	2,60	4,785	70,90	92	76	71	65	60	56	53	52
76,10	x	2,65	4,874	70,80	93	78	73	66	61	57	55	53
76,10	x	2,90	5,315	70,30	102	85	80	73	67	63	60	58
76,10	x	3,00	5,491	70,10	106	88	83	76	70	65	62	60
76,10	x	3,20	5,841	69,70	113	94	89	81	75	70	66	64
76,10	x	3,25	5,929	69,60	115	95	90	82	76	71	68	65
76,10	x	3,60	6,535	68,90	127	105	100	92	85	79	75	73
76,10	x	3,65	6,622	68,80	129	107	102	93	86	80	76	74
76,10	x	4,00	7,222	68,10	141	117	112	102	95	88	84	81
76,10	x	4,50	8,068	67,10	159	132	127	116	107	100	95	92
76,10	x	5,00	8,902	66,10	176	146	142	130	120	112	107	103
76,10	x	6,30	11,011	63,50	222	184	183	167	154	144	137	133
76,10	x	10,66	17,468	54,78	376	334	312	305	281	262	250	242
76,20	x	1,63	3,044	72,94	57	48	44	40	37	35	33	32
78,00	x	1,50	2,873	75,00	52	43	39	36	33	31	30	29
79,00	x	2,00	3,856	75,00	68	56	52	48	44	41	39	38
80,00	x	1,50	2,948	77,00	50	42	38	35	32	30	29	28
80,00	x	2,00	3,906	76,00	67	56	52	47	44	41	39	38
80,00	x	2,50	4,852	75,00	84	70	65	59	55	51	49	47
80,00	x	3,00	5,784	74,00	101	84	79	72	66	62	59	57
80,00	x	4,00	7,612	72,00	134	111	106	97	90	83	80	77
80,00	x	5,00	9,390	70,00	168	139	135	123	114	106	101	98
81,00	x	3,00	3,859	75,00	99	83	78	71	65	61	58	56
82,50	x	3,60	7,112	75,30	117	97	92	84	78	72	69	67
83,00	x	1,50	3,061	80,00	48	40	37	34	31	29	28	27
83,00	x	3,50	6,967	76,00	113	94	89	81	75	70	67	65
83,00	x	5,50	10,673	72,00	178	148	144	131	121	113	108	104
84,00	x	2,00	4,107	80,00	64	53	49	45	41	39	37	36
84,00	x	4,00	8,013	76,00	128	106	101	92	85	79	76	73
85,00	x	2,00	4,157	81,00	63	52	48	44	41	38	36	35
85,00	x	2,50	5,165	80,00	79	66	61	56	51	48	46	44
86,00	x	3,00	6,235	80,00	94	78	73	67	61	57	55	53
86,00	x	6,00	12,019	74,00	187	155	152	139	128	119	114	110
86,00	x	7,50	14,742	71,00	234	194	194	177	164	152	146	141
88,90	x	1,50	3,283	85,90	45	38	35	32	29	27	26	25
88,90	x	1,60	3,498	85,70	48	40	37	34	31	29	28	27
88,90	x	2,00	4,352	84,90	60	50	46	42	39	36	35	34
88,90	x	2,11	4,585	84,68	64	53	49	45	41	38	37	36
88,90	x	2,30	4,987	84,30	69	58	53	49	45	42	40	39

UD	x	S	kg/m	ID	20°C	100°C	150°C	200°C	250°C	300°C	350°C	400°C
88,90	x	2,35	5,093	84,20	71	59	55	50	46	43	41	40
88,90	x	2,50	5,409	83,90	75	63	58	53	49	46	44	42
88,90	x	2,60	5,618	83,70	78	65	61	55	51	48	46	44
88,90	x	2,65	5,723	83,60	80	66	62	56	52	49	46	45
88,90	x	2,90	6,245	83,10	88	73	68	62	57	53	51	49
88,90	x	3,00	6,453	82,90	91	75	70	64	59	55	53	51
88,90	x	3,05	6,557	82,80	92	76	72	65	60	56	54	52
88,90	x	3,20	6,867	82,50	97	80	75	69	63	59	56	55
88,90	x	3,25	6,970	82,40	98	81	77	70	64	60	57	56
88,90	x	3,60	7,689	81,70	109	90	85	78	72	67	64	62
88,90	x	4,00	8,504	80,90	121	100	95	87	80	75	71	69
88,90	x	4,05	8,605	80,80	122	102	96	88	81	76	72	70
88,90	x	4,50	9,510	79,90	136	113	108	98	91	85	81	78
88,90	x	5,00	10,504	78,90	151	125	120	110	102	95	90	88
88,90	x	5,49	11,466	77,92	166	138	133	122	112	105	100	97
88,90	x	6,30	13,030	76,30	190	158	155	141	130	121	116	112
88,90	x	7,62	15,509	73,66	230	191	190	174	160	149	143	138
88,90	x	11,13	21,674	66,64	336	292	279	267	247	230	219	213
88,90	x	15,24	28,109	58,42	460	426	389	382	359	335	320	310
88,90	x	17,50	31,287	53,90	528	507	463	439	428	398	381	369
89,00	x	6,50	13,428	76,00	196	163	160	146	135	125	120	116
90,00	x	5,00	10,642	80,00	149	124	119	109	100	93	89	86
90,00	x	6,00	12,620	78,00	179	149	145	132	122	114	108	105
92,00	x	4,00	8,814	84,00	117	97	92	84	77	72	69	67
93,00	x	2,00	4,557	89,00	58	48	44	40	37	35	33	32
95,00	x	2,50	5,791	90,00	71	59	54	50	46	43	41	40
97,00	x	4,00	9,315	89,00	111	92	87	79	73	68	65	63
100,00	x	3,00	7,287	94,00	81	67	62	57	53	49	47	45
100,00	x	5,00	11,894	90,00	134	111	106	97	90	83	80	77
100,00	x	8,00	18,429	84,00	215	178	176	161	149	138	132	128
101,60	x	1,50	3,760	98,60	40	33	30	27	25	24	23	22
101,60	x	2,0	4,988	97,60	53	44	40	37	34	32	30	29
101,60	x	2,11	5,256	97,38	56	46	43	39	36	33	32	31
101,60	x	3,05	7,526	95,50	81	67	62	57	53	49	47	45
101,60	x	3,60	8,834	94,40	95	79	74	68	62	58	56	54
101,60	x	4,00	9,776	93,60	106	88	83	75	70	65	62	60
101,60	x	4,05	9,893	93,50	107	89	84	76	71	66	63	61
101,60	x	4,75	11,519	92,10	125	104	99	90	83	78	74	72
101,60	x	5,00	12,094	91,60	132	110	105	95	88	82	78	76
101,60	x	5,74	13,778	90,12	152	126	121	111	102	95	91	88
101,60	x	7,60	17,889	86,40	201	167	164	150	138	129	123	119
101,60	x	8,08	18,921	85,44	213	177	175	160	148	138	131	127
102,00	x	3,00	7,437	96,00	79	66	61	56	51	48	46	44
102,00	x	3,50	8,633	95,00	92	76	72	65	60	56	54	52
102,00	x	6,50	15,544	89,00	171	142	138	126	116	108	103	100
103,00	x	1,50	3,812	100,00	39	32	30	27	25	23	22	22
104,00	x	2,00	5,108	100,00	52	43	39	36	33	31	30	29

UD	x	S	kg/m	ID	20°C	100°C	150°C	200°C	250°C	300°C	350°C	400°C
104,00	x	6,00	14,724	92,00	155	129	124	113	104	97	93	90
105,00	x	2,50	6,417	100,00	64	53	49	45	41	39	37	36
106,00	x	2,75	7,110	100,50	70	58	54	49	45	42	40	39
106,00	x	2,80	7,236	100,40	71	59	55	50	46	43	41	40
106,00	x	3,00	7,737	100,00	76	63	59	54	49	46	44	43
106,00	x	3,20	8,237	99,60	81	67	63	57	53	49	47	46
108,00	x	2,00	5,308	104,00	50	41	38	35	32	30	28	28
108,00	x	2,60	6,862	102,80	65	54	50	45	42	39	37	36
108,00	x	2,90	7,632	102,20	72	60	56	51	47	44	42	40
108,00	x	3,00	7,888	102,00	75	62	58	53	49	45	43	42
108,00	x	3,20	8,397	101,60	80	66	62	56	52	48	46	45
108,00	x	3,60	9,411	100,80	89	74	69	63	59	55	52	51
108,00	x	4,00	10,417	100,00	99	83	78	71	65	61	58	56
108,00	x	4,05	10,542	99,90	101	84	79	72	66	62	59	57
108,00	x	4,50	11,662	99,00	112	93	88	80	74	69	66	64
108,00	x	5,00	12,896	98,00	124	103	98	89	83	77	74	71
108,00	x	5,40	13,873	97,20	134	111	106	97	90	83	80	77
108,00	x	5,60	14,359	96,80	139	116	110	101	93	87	83	80
108,00	x	6,30	16,043	95,40	157	130	125	114	106	98	94	91
110,00	x	6,00	15,625	98,00	146	122	117	106	98	92	87	85
112,00	x	4,00	10,817	104,00	96	80	75	68	63	59	56	54
112,00	x	6,00	15,925	100,00	144	119	114	104	96	90	86	83
112,00	x	8,00	20,833	96,00	192	159	156	142	131	122	117	113
114,30	x	1,50	4,237	111,30	35	29	27	24	23	21	20	19
114,30	x	1,60	4,515	111,10	38	31	29	26	24	22	21	21
114,30	x	2,00	5,624	110,30	47	39	36	33	30	28	27	26
114,30	x	2,11	5,927	110,08	50	41	38	35	32	30	28	27
114,30	x	2,50	6,999	109,30	59	49	45	41	38	35	34	33
114,30	x	2,60	7,272	109,10	61	51	47	43	39	37	35	34
114,30	x	2,65	7,409	109,00	62	52	48	44	40	37	36	35
114,30	x	2,90	8,089	108,50	68	57	52	48	44	41	39	38
114,30	x	3,00	8,361	108,30	70	58	54	50	46	43	41	39
114,30	x	3,05	8,496	108,20	72	59	55	50	47	43	41	40
114,30	x	3,20	8,902	107,90	75	62	58	53	49	46	44	42
114,30	x	3,25	9,037	107,80	76	63	59	54	50	46	44	43
114,30	x	3,60	9,979	107,10	85	70	66	60	55	51	49	48
114,30	x	4,00	11,048	106,30	94	78	73	67	62	57	55	53
114,30	x	4,05	11,181	106,20	95	79	74	68	62	58	56	54
114,30	x	4,50	12,372	105,30	106	88	83	75	70	65	62	60
114,30	x	5,40	14,725	103,50	127	105	100	91	84	79	75	73
114,30	x	6,02	16,322	102,26	141	117	112	103	95	88	84	82
114,30	x	6,30	17,037	101,70	148	123	118	108	99	93	88	86
114,30	x	7,10	19,058	100,10	167	138	134	122	113	105	101	97
114,30	x	7,11	19,084	100,08	167	139	134	123	113	105	101	98
114,30	x	8,56	22,665	97,18	201	167	164	150	138	129	123	119
114,30	x	11,13	28,753	92,04	261	219	217	200	185	172	165	159
114,30	x	13,49	34,053	87,32	317	273	263	249	230	214	205	198

UD	x	S	kg/m	ID	20°C	100°C	150°C	200°C	250°C	300°C	350°C	400°C
114,30	x	16,00	39,383	82,30	376	333	312	304	281	262	250	242
114,30	x	17,12	41,660	80,06	402	361	334	330	305	284	271	263
121,00	x	4,00	11,719	113,00	89	74	69	63	58	54	52	50
123,00	x	1,50	4,564	120,00	33	27	25	23	21	19	19	18
127,00	x	1,63	5,117	123,74	34	29	26	24	22	21	20	19
127,00	x	4,00	12,320	119,00	85	70	66	60	55	51	49	48
127,00	x	5,00	15,274	117,00	106	88	83	75	70	65	62	60
127,00	x	9,53	28,032	107,94	201	167	164	150	139	129	123	120
127,00	x	10,00	29,297	107,00	211	175	173	158	146	136	130	126
128,00	x	1,50	4,751	125,00	31	26	24	22	20	19	18	17
129,00	x	2,00	6,360	125,00	42	35	32	29	27	25	24	23
130,00	x	2,50	7,982	125,00	52	43	39	36	33	31	30	29
131,00	x	3,00	9,615	125,00	61	51	47	43	40	37	35	34
133,00	x	1,50	4,939	130,00	30	25	23	21	19	18	17	17
133,00	x	2,00	3,530	129,00	40	34	31	28	26	24	23	22
133,00	x	2,50	8,169	128,00	50	42	39	35	32	30	29	28
133,00	x	2,60	8,490	127,80	52	44	40	37	34	31	30	29
133,00	x	2,90	9,447	127,20	59	49	45	41	38	35	34	33
133,00	x	3,00	9,766	127,00	61	50	46	42	39	36	35	34
133,00	x	4,00	12,921	125,00	81	67	62	57	53	49	47	45
133,00	x	5,00	16,026	123,00	101	84	79	72	66	62	59	57
133,00	x	6,30	19,987	120,40	127	106	100	92	85	79	75	73
133,00	x	20,00	56,590	93,00	404	363	335	332	306	285	272	264
135,00	x	5,00	16,276	125,00	99	83	78	71	65	61	58	56
139,70	x	1,50	5,191	136,70	29	24	22	20	18	17	16	16
139,70	x	2,00	6,896	135,70	38	32	29	27	25	23	22	21
139,70	x	2,50	8,589	134,70	48	40	37	33	31	29	27	27
139,70	x	2,60	8,926	134,50	50	41	38	35	32	30	29	28
139,70	x	3,00	10,269	133,70	58	48	44	40	37	35	33	32
139,70	x	4,00	13,592	131,70	77	64	59	54	50	47	45	43
139,70	x	5,00	16,864	129,70	96	80	75	68	63	59	56	54
139,70	x	6,30	21,044	127,10	121	100	95	87	80	75	71	69
139,70	x	7,10	23,574	125,50	136	113	108	99	91	85	81	79
139,70	x	10,00	32,477	119,70	192	160	156	143	132	123	117	114
141,30	x	2,77	9,609	135,76	53	44	40	37	34	32	30	29
141,30	x	3,40	11,740	134,50	65	54	50	45	42	39	37	36
141,30	x	6,55	22,101	128,20	124	103	98	90	83	77	74	71
141,30	x	9,52	31,414	122,26	181	150	146	134	123	115	110	106
141,30	x	9,53	31,444	122,24	181	150	146	134	123	115	110	106
141,30	x	12,50	40,314	116,30	237	197	197	180	166	155	148	143
152,00	x	1,00	3,781	150,00	18	15	13	12	11	10	10	10
152,40	x	7,00	25,486	138,40	123	102	97	89	82	76	73	71
152,40	x	7,50	27,212	137,40	132	110	105	95	88	82	78	76
152,40	x	9,00	32,317	134,40	158	132	127	116	107	100	95	92
153,00	x	1,50	5,690	150,00	26	22	20	18	17	16	15	14
154,00	x	2,00	7,612	150,00	35	29	26	24	22	21	20	19
155,00	x	2,50	9,547	150,00	43	36	33	30	28	26	25	24

UD	x	S	kg/m	ID	20°C	100°C	150°C	200°C	250°C	300°C	350°C	400°C
156,00	x	3,00	11,493	150,00	52	43	39	36	33	31	30	29
158,00	x	4,00	15,425	150,00	68	56	52	48	44	41	39	38
159,00	x	2,00	7,863	155,00	34	28	26	23	22	20	19	19
159,00	x	2,50	9,797	154,00	42	35	32	29	27	25	24	23
159,00	x	2,60	10,182	153,80	44	36	33	31	28	26	25	24
159,00	x	3,00	11,719	153,00	51	42	39	35	33	30	29	28
159,00	x	4,00	15,525	151,00	68	56	52	47	44	41	39	38
159,00	x	4,50	17,409	150,00	76	63	59	54	49	46	44	43
159,00	x	6,30	24,089	146,40	106	88	83	76	70	65	62	60
159,00	x	8,00	30,248	143,00	135	112	107	98	90	84	80	78
159,40	x	8,00	30,328	143,40	135	112	107	97	90	84	80	78
159,40	x	12,50	45,980	134,40	210	175	173	158	145	135	129	125
162,00	x	5,00	19,656	152,00	83	69	64	59	54	50	48	47
168,28	x	2,77	11,480	162,74	44	37	34	31	28	26	25	24
168,28	x	3,40	14,037	161,48	54	45	41	38	35	33	31	30
168,28	x	7,11	28,694	154,06	113	94	89	81	75	70	67	65
168,28	x	8,08	32,412	152,12	129	107	102	93	86	80	76	74
168,28	x	8,74	34,915	150,80	139	116	111	101	93	87	83	80
168,28	x	10,97	43,211	146,34	175	145	141	129	119	111	106	103
168,28	x	14,27	55,031	139,74	228	189	188	172	159	148	141	137
168,28	x	18,24	68,528	131,80	291	248	242	226	209	194	186	180
168,28	x	21,95	80,427	124,38	350	307	291	280	259	241	230	223
168,30	x	1,50	6,265	165,30	24	20	18	16	15	14	14	13
168,30	x	2,00	8,328	164,30	32	26	24	22	20	19	18	18
168,30	x	2,50	10,379	163,30	40	33	30	28	26	24	23	22
168,30	x	2,60	10,788	163,10	41	34	32	29	27	25	24	23
168,30	x	3,00	12,417	162,30	48	40	37	33	31	29	27	27
168,30	x	3,20	13,229	161,90	51	42	39	36	33	31	29	28
168,30	x	3,40	14,039	161,50	54	45	41	38	35	33	31	30
168,30	x	4,00	16,456	160,30	64	53	49	45	41	38	37	36
168,30	x	4,50	18,457	159,30	72	60	55	50	47	43	41	40
168,30	x	5,00	20,445	158,30	80	66	62	56	52	48	46	45
168,30	x	7,10	28,659	154,10	113	94	89	81	75	70	67	65
168,30	x	8,74	34,920	150,82	139	116	111	101	93	87	83	80
168,30	x	12,70	49,482	142,90	202	168	165	151	139	130	124	120
168,30	x	14,20	54,793	139,90	226	188	187	171	158	147	140	136
168,30	x	15,39	58,926	137,52	245	205	204	187	172	161	153	149
168,30	x	17,50	66,081	133,30	279	236	232	216	199	185	177	172
168,30	x	20,00	74,269	128,30	319	275	265	251	232	216	206	200
168,30	x	20,85	76,981	126,60	332	289	276	264	244	227	217	210
168,30	x	22,00	80,594	124,30	351	308	291	281	259	241	231	223
178,00	x	1,50	6,629	175,00	23	19	17	16	14	13	13	12
180,00	x	1,25	5,595	177,50	19	15	14	13	12	11	11	10
181,00	x	3,00	13,371	175,00	44	37	34	31	29	27	25	25
193,70	x	3,00	14,325	187,70	42	35	32	29	27	25	24	23
193,70	x	8,00	37,199	177,70	111	92	87	79	73	68	65	63
203,00	x	1,50	7,568	200,00	20	16	15	14	13	12	11	11

UD	x	S	kg/m	ID	20°C	100°C	150°C	200°C	250°C	300°C	350°C	400°C
204,00	x	2,00	10,116	200,00	26	22	20	18	17	16	15	14
205,00	x	2,50	12,677	200,00	33	27	25	23	21	19	19	18
206,00	x	3,00	15,249	200,00	39	32	30	27	25	23	22	22
207,00	x	3,50	17,835	200,00	45	38	35	32	29	27	26	25
208,00	x	4,00	20,433	200,00	52	43	39	36	33	31	30	29
212,00	x	5,00	25,916	202,00	63	53	49	44	41	38	36	35
215,00	x	2,50	13,303	210,00	31	26	24	22	20	19	18	17
216,00	x	2,00	10,717	212,00	25	21	19	17	16	15	14	14
216,00	x	3,00	16,001	210,00	37	31	28	26	24	22	21	21
219,08	x	2,77	15,003	213,54	34	28	26	23	22	20	19	19
219,08	x	3,76	20,272	211,56	46	38	35	32	30	28	26	26
219,08	x	6,35	33,825	206,38	78	65	60	55	51	47	45	44
219,08	x	8,18	43,198	202,72	100	83	78	71	66	61	59	57
219,08	x	10,30	53,897	198,46	126	105	100	91	84	78	75	72
219,08	x	12,70	65,630	193,68	156	129	124	114	105	98	93	90
219,08	x	15,09	77,078	188,90	185	153	150	137	126	118	112	109
219,08	x	18,24	91,730	182,60	223	186	184	168	155	145	138	134
219,08	x	23,01	112,970	173,06	282	239	234	218	201	188	179	174
219,10	x	2,00	10,872	215,10	24	20	19	17	16	15	14	13
219,10	x	2,50	13,559	214,10	31	25	23	21	20	18	17	17
219,10	x	2,60	14,095	213,90	32	26	24	22	20	19	18	18
219,10	x	2,90	15,700	213,30	36	29	27	25	23	21	20	20
219,10	x	3,00	16,233	213,10	37	31	28	25	24	22	21	20
219,10	x	3,20	17,300	212,70	39	33	30	27	25	23	22	22
219,10	x	3,76	20,274	211,58	46	38	35	32	30	28	26	26
219,10	x	4,00	21,544	211,10	49	41	37	34	32	29	28	27
219,10	x	6,00	32,016	207,10	73	61	57	52	48	45	43	41
219,10	x	6,30	33,570	206,50	77	64	60	54	50	47	45	43
219,10	x	7,10	37,690	204,90	87	72	67	62	57	53	51	49
219,10	x	8,20	43,304	202,70	100	83	78	72	66	62	59	57
219,10	x	10,00	52,359	199,10	122	102	97	88	81	76	72	70
219,10	x	11,13	57,960	196,84	136	113	108	99	91	85	81	79
219,10	x	14,20	72,856	190,70	174	144	140	128	118	110	105	102
219,10	x	18,20	91,556	182,70	223	185	184	168	155	144	138	134
219,10	x	20,00	99,709	179,10	245	204	203	186	172	160	153	148
219,10	x	23,10	113,371	172,90	283	240	235	219	202	188	180	174
228,00	x	1,50	8,507	225,00	18	15	13	12	11	10	10	10
244,50	x	8,00	47,376	228,50	88	73	68	62	57	54	51	50
253,00	x	1,50	9,446	250,00	16	13	12	11	10	9	9	9
254,00	x	2,00	12,620	250,00	21	18	16	15	13	13	12	12
255,00	x	2,50	15,807	250,00	26	22	20	18	17	16	15	14
256,00	x	3,00	19,005	250,00	31	26	24	22	20	19	18	17
257,00	x	3,50	22,217	250,00	37	30	28	25	23	22	21	20
262,00	x	6,00	38,461	250,00	61	51	47	43	40	37	35	34
267,00	x	3,00	19,832	261,00	30	25	23	21	19	18	17	17
267,00	x	8,80	56,895	249,40	88	73	69	63	58	54	52	50
273,00	x	2,00	13,572	269,00	20	16	15	14	12	12	11	11

UD	x	S	kg/m	ID	20°C	100°C	150°C	200°C	250°C	300°C	350°C	400°C
273,00	x	2,50	16,933	268,00	25	20	19	17	16	15	14	13
273,00	x	2,60	17,604	267,80	26	21	19	18	16	15	14	14
273,00	x	2,90	19,614	267,20	29	24	22	20	18	17	16	16
273,00	x	3,00	20,282	267,00	29	24	22	20	19	18	17	16
273,00	x	3,20	21,619	266,60	31	26	24	22	20	19	18	17
273,00	x	4,00	26,943	265,00	39	33	30	27	25	23	22	22
273,00	x	8,20	54,371	256,60	81	67	62	57	53	49	47	45
273,00	x	8,80	58,217	255,40	86	72	67	61	57	53	50	49
273,00	x	9,30	61,408	254,40	91	76	71	65	60	56	53	52
273,00	x	11,00	72,165	251,00	108	90	85	77	71	66	64	62
273,00	x	12,00	78,425	249,00	118	98	93	85	78	73	70	67
273,00	x	22,20	139,417	228,60	218	181	180	164	151	141	135	131
273,05	x	4,19	28,208	264,67	41	34	31	29	26	25	24	23
273,05	x	6,35	42,406	260,35	62	52	48	44	40	38	36	35
273,05	x	9,27	61,229	254,51	91	76	71	65	60	56	53	51
273,05	x	12,70	82,793	247,65	125	104	98	90	83	77	74	72
273,05	x	15,09	97,471	242,87	148	123	118	108	100	93	89	86
273,05	x	21,41	134,906	230,23	210	175	173	158	145	135	129	125
273,05	x	25,40	157,509	222,25	250	208	207	190	176	164	156	152
273,05	x	28,58	174,953	215,89	281	238	233	217	201	187	179	173
298,50	x	10,00	72,240	278,50	90	75	70	64	59	55	52	51
303,00	x	1,50	11,324	300,00	13	11	10	9	8	8	7	7
304,00	x	2,00	15,124	300,00	18	15	13	12	11	10	10	10
305,00	x	2,50	18,937	300,00	22	18	17	15	14	13	12	12
306,00	x	3,00	22,761	300,00	26	22	20	18	17	16	15	14
307,00	x	3,50	26,599	300,00	31	25	23	21	20	18	17	17
323,85	x	3,96	31,720	315,93	33	27	25	23	21	20	19	18
323,85	x	4,57	36,536	314,71	38	31	29	26	24	23	22	21
323,85	x	6,35	50,484	311,15	53	44	40	37	34	32	30	29
323,85	x	8,38	66,197	307,09	69	58	53	49	45	42	40	39
323,85	x	9,53	75,007	304,79	79	66	61	56	51	48	46	44
323,85	x	12,70	98,948	298,45	105	87	82	75	69	65	62	60
323,85	x	17,45	133,881	288,95	145	120	115	105	97	90	86	84
323,85	x	28,58	211,308	266,69	237	197	197	179	166	154	147	143
323,85	x	33,32	242,399	257,21	276	233	229	213	197	183	175	170
323,90	x	2,00	16,121	319,90	17	14	12	11	11	10	9	9
323,90	x	2,50	20,120	318,90	21	17	16	14	13	12	12	11
323,90	x	2,60	20,918	318,70	22	18	16	15	14	13	12	12
323,90	x	3,00	24,106	317,90	25	21	19	17	16	15	14	14
323,90	x	3,20	25,697	317,50	27	22	20	18	17	16	15	15
323,90	x	4,00	32,041	315,90	33	28	25	23	21	20	19	13
323,90	x	8,80	69,433	306,30	73	61	56	51	47	44	42	41
323,90	x	9,53	75,018	304,84	79	66	61	56	51	48	46	44
323,90	x	10,00	78,601	303,90	83	69	64	59	54	50	48	47
323,90	x	10,20	80,121	303,50	85	70	66	60	55	51	49	48
323,90	x	11,70	91,465	300,50	97	80	76	69	64	59	57	55
323,90	x	16,00	123,357	291,90	133	110	105	96	88	82	79	76

UD	x	S	kg/m	ID	20°C	100°C	150°C	200°C	250°C	300°C	350°C	400°C
323,90	x	20,00	152,193	283,90	166	138	133	122	112	105	100	97
353,00	x	1,50	13,202	350,00	11	9	9	8	7	7	6	6
355,00	x	2,50	22,067	350,00	19	16	14	13	12	11	11	10
355,60	x	2,50	22,104	350,60	19	16	14	13	12	11	11	10
355,60	x	3,00	26,487	349,60	23	19	17	16	14	13	13	12
355,60	x	4,00	35,216	347,60	30	25	23	21	19	18	17	17
355,60	x	4,78	41,990	346,04	36	30	27	25	23	21	21	20
355,60	x	9,53	82,583	336,54	72	60	55	51	47	44	42	40
355,60	x	12,70	109,045	330,20	96	80	75	68	63	59	56	54
355,60	x	14,20	121,391	327,20	107	89	84	77	71	66	63	61
355,60	x	19,05	160,538	317,50	144	119	114	104	96	90	86	83
355,60	x	27,80	228,186	300,00	210	174	172	157	145	135	129	125
356,00	x	3,00	26,517	350,00	23	19	17	16	14	13	13	12
357,00	x	3,50	30,981	350,00	26	22	20	18	17	16	15	14
358,00	x	4,00	35,457	350,00	30	25	23	21	19	18	17	17
368,00	x	11,00	98,332	346,00	80	67	62	57	52	49	47	45
368,00	x	14,20	125,800	339,60	104	86	81	74	68	64	61	59
405,00	x	2,50	25,197	400,00	17	14	12	11	11	10	9	9
406,00	x	3,00	30,273	400,00	20	16	15	14	13	12	11	11
406,40	x	3,00	30,303	400,40	20	16	15	14	13	12	11	11
406,40	x	4,00	40,304	398,40	26	22	20	18	17	16	15	15
406,40	x	4,78	48,070	396,84	32	26	24	22	20	19	18	17
406,40	x	8,00	79,807	390,40	53	44	40	37	34	32	30	29
406,40	x	9,53	94,706	387,34	63	52	48	44	41	38	36	35
406,40	x	16,00	156,410	374,40	106	88	83	75	70	65	62	60
406,40	x	22,20	213,572	362,00	147	122	117	107	98	92	88	85
406,40	x	40,46	370,741	325,48	267	225	222	205	190	177	169	163
408,00	x	4,00	40,465	400,00	26	22	22	18	17	16	15	14
410,00	x	5,00	50,706	400,00	33	27	25	23	21	19	19	18
412,00	x	6,00	60,997	400,00	39	32	30	27	25	23	22	22
456,00	x	3,00	34,029	450,00	18	15	13	12	11	10	10	10
457,20	x	3,00	34,120	451,20	18	15	13	12	11	10	10	10
457,20	x	4,00	45,393	449,20	23	19	18	16	15	14	13	13
457,20	x	4,78	54,151	447,64	28	23	21	19	18	17	16	15
457,20	x	9,73	109,021	437,74	57	47	44	40	37	34	33	32
457,20	x	11,13	124,318	434,94	65	54	50	46	42	39	38	37
457,20	x	25,00	270,557	407,20	147	122	117	107	99	92	88	85
457,20	x	34,93	369,337	387,34	205	170	168	153	141	132	126	122
458,00	x	4,00	45,473	450,00	23	19	18	16	15	14	13	13
462,00	x	6,00	68,509	450,00	35	29	26	24	22	21	20	19
506,00	x	3,00	37,785	500,00	16	13	12	11	10	9	9	9
508,00	x	3,00	37,936	502,00	16	13	12	11	10	9	9	9
508,00	x	4,00	50,481	500,00	21	18	16	15	13	13	12	12
508,00	x	5,54	69,702	496,92	29	24	22	20	19	17	17	16
508,00	x	9,53	118,950	488,94	50	42	38	35	32	30	29	28
508,00	x	20,62	251,646	466,76	109	90	85	78	72	67	64	62
508,00	x	33,10	393,609	441,80	175	145	141	129	119	111	106	103

UD	x	S	kg/m	ID	20°C	100°C	150°C	200°C	250°C	300°C	350°C	400°C
508,00	x	50,00	573,416	408,00	264	222	219	203	187	174	167	161
512,00	x	6,00	76,021	500,00	31	26	24	22	20	19	18	17
558,80	x	3,00	41,752	552,80	14	12	11	10	9	9	8	8
606,00	x	3,00	45,297	600,00	13	11	10	9	8	8	7	7
608,00	x	4,00	60,497	600,00	18	15	13	12	11	10	10	10
609,60	x	5,54	83,796	598,52	24	20	18	17	16	14	14	13
609,60	x	3,00	45,568	603,60	13	11	10	9	8	8	7	7
609,60	x	6,35	95,919	596,90	28	23	21	19	18	17	16	15
609,60	x	9,53	143,195	590,54	42	35	32	29	27	25	24	23
708,00	x	4,00	70,513	700,00	15	13	11	10	10	9	9	8
712,00	x	6,00	106,069	700,00	23	19	17	16	14	13	13	12
758,00	x	4,00	75,521	750,00	14	12	11	10	9	8	8	8
810,00	x	5,00	100,786	800,00	17	14	12	11	11	10	9	9
812,00	x	6,00	121,093	800,00	20	16	15	14	13	12	11	11
910,00	x	5,00	113,306	900,00	15	12	11	10	9	9	8	8
910,00	x	6,00	135,817	898,00	18	15	13	12	11	10	10	10

Austenitisch roestvaststaal AISI 304(L) en 316(L)

Austenitic stainless steel AISI 304(L) and 316(L)

Austenitischer, nichtrostender Stahl AISI 304(L) und 316(L)

Acier inoxydable austénitique AISI 304 (L) et 316 (L)

Technische bijlagen

Technical Data

Technischen Daten

Données techniques

Bij de aanwezigheid van circa 12 % chroom wordt staal in zekere mate corrosievast dankzij de vorming van een passieve oxydehuid van chroomoxyde die het materiaal afsluit voor allerlei waterige milieus die normaal gesproken tot corrosie zouden leiden. We spreken bij een dergelijk chroomgehalte over chroomstaal. Indien dit chroomgehalte verder stijgt dan neemt ook de corrosiebestendigheid toe en dat is de reden dat dit in de praktijk veelal 18% en zelfs nog hoger is. Om de austenietstructuur te kunnen bereiken is het ook nodig dat er circa 8% nikkel aan het materiaal wordt toegevoegd waardoor de corrosiebestendigheid in het algemeen verder wordt vergroot. Zo ontstaat de kwaliteit AISI 304 en een bekende variant is de kwaliteit AISI 304L dat een verlaagd koolstofgehalte heeft. Een laag koolstofgehalte heeft het voordeel dat bij thermisch zwaar belaste onderdelen de kans geringer is dat men de gevreesde chroomcarbiden krijgt. Door de toevoeging van 8% nikkel krijgt men significante veranderingen in allerlei kenmerken van het materiaal. We kunnen dan vooral denken aan:

- andere mechanische eigenschappen;
- betere verwerkbaarheid en taaheid;
- hogere temperatuursterkte;
- verbeterde lasbaarheid;
- fysische eigenschappen, zoals een lager warmtegeleidingsvermogen en een hogere uitzettingscoëfficiënt;
- het niet magnetisch zijn.

Het toepassingsgebied van deze legering is veel ruimer dan bij chroomstaal vanwege de unieke en vaak veel betere eigenschappen. Gedacht kan worden aan bijvoorbeeld installaties t.b.v. de zuivel- en voedselindustrie alsmede voor constructies en pijpsystemen voor allerlei milde chemische processen.

Molybdeen bevordert de passiviteit van het austenitische roestvaststaal omdat het de chroomoxidehuid verder versterkt. Bij 2% molybdeen treedt er een significante verbetering op van de corrosiebestendigheid waardoor de AISI 316(L) typen ontstaan. Dit type levert zeer goede corrosieprestaties in vele chemische processen en zelfs onder bepaalde condities in zeewater. Molybdeen heeft hetzelfde effect op de structuur als het chroom.

At chromium contents above about 12%, steel develops a degree of corrosion resistance thanks to the formation of a passive chromium oxide film that seals off the material from all sorts of aqueous environments, which in normal circumstances would lead to corrosion. The term chromium steel is used for these chromium contents. If the chromium content is increased, the corrosion resistance also increases, and this is why in practice the chromium content is usually 18% or even higher. In order to reach an austenitic structure, it is also necessary to add approximately 8% nickel to the material, which generally speaking increases the corrosion resistance further. This is the basis of the AISI 304 grade. A well-known variation on this grade is AISI 304L, which has a reduced carbon content. The advantage of a low carbon content is that there is a smaller chance of the formation of the dreaded chromium carbides in components subjected to heavy thermal loads. The addition of 8% nickel brings about significant changes in all sorts of material characteristics. The most important of these are:

- different mechanical properties;
- better workability and ductility;
- greater strength at high temperature;
- improved weldability;
- physical properties such as lower thermal conductivity and a larger coefficient of thermal expansion;
- not magnetic.

The field of application of this alloy is much greater than for chromium steel because of the unique and often much better properties. Applications include installations in the dairy and food processing industry, and also structures and piping in all kinds of mild chemical processes.

Molybdenum enhances the passivity of austenitic stainless steel because it strengthens the chromium oxide film still further. A significant improvement in corrosion resistance occurs at the 2% molybdenum level, and this has given rise to the AISI 316(L) types. This type has good corrosion performance in many chemical processes and even in sea water under certain conditions. Molybdenum has the same effect on the structure as chromium.

Bei einem Chromgehalt von etwa 12% erreicht Stahl dank der Bildung einer passiven Oxidhaut aus Chromoxid, die das Material vor verschiedenen wäßrigen Umgebungen schützt, die normalerweise Korrosion herbeiführen würden, ein gewisses Maß an Korrosionsbeständigkeit. Bei einem derartigen Chromgehalt sprechen wir von Chromstahl. Steigt dieser Chromgehalt weiter an, nimmt auch die Korrosionsbeständigkeit zu, und deshalb ist der Chromgehalt in der Praxis häufig 18% und höher. Um die Austenitstruktur erreichen zu können, ist es notwendig dem Material etwa 8% Nickel hinzuzufügen, was die Korrosionsbeständigkeit im allgemeinen weiter verbessert. Auf diese Weise entsteht die Qualität AISI 304. Eine bekannte Variante davon ist die Qualität AISI 304L, die einen herabgesetzten Kohlenstoffgehalt hat. Ein niedriger Kohlenstoffgehalt hat den Vorteil, daß die Gefahr der Bildung der gefürchteten Chromkarbide bei thermisch stark belasteten Teilen geringer ist. Die Hinzufügung von 8% Nickel bewirkt signifikante Veränderungen bei verschiedenen Materialmerkmalen. Zu denken ist dabei vor allem an folgendes:

- veränderte mechanische Eigenschaften;
- bessere Verarbeitbarkeit und Duktilität;
- bessere Festigkeit bei hohen Temperaturen;
- verbesserte Schweißbarkeit;
- not physikalische Eigenschaften, wie niedrigeres Wärmeleitvermögen und höherer Wärmeausdehnungskoeffizient;
- nicht magnetisch

Der Anwendungsbereich dieser Legierung ist aufgrund der einzigartigen und häufig viel besseren Eigenschaften wesentlich größer als der von Chromstahl. In Frage kommen beispielsweise Anlagen für die Milchwirtschaft und Nahrungsmittelindustrie sowie Konstruktionen und Rohrsysteme für milde chemische Prozesse unterschiedlicher Art.

Molybdän fördert die Passivität des austenitischen, nichtrostenden Stahls, da es die Chromoxidhaut zusätzlich verstärkt. Ein Molybdänanteil von 2% sorgt für eine signifikante Verbesserung der Korrosionsbeständigkeit, so daß die Typen AISI 316(L) entstehen. Diese Sorte zeigt sehr gute Korrosionsleistungen bei vielen chemischen Prozessen und sogar unter bestimmten Bedingungen in Salzwasser. Molybdän hat die gleiche Wirkung auf die Struktur wie Chrom.

Lorsque la teneur en chrome est supérieure à 12 % environ, l'acier présente un certain niveau de résistance à la corrosion grâce à la formation d'un film passif d'oxyde de chrome qui étanchéifie le matériau dans tous les types d'environnements aqueux qui conduiraient en conditions normales à la corrosion. Le terme d'acier chromifère est utilisé en cas de teneurs en chrome similaires. Si la teneur en chrome augmente, la résistance à la corrosion s'accroît. Dans la pratique, la teneur en chrome est de 18 %, voire davantage. D'obtenir la structure austénitique, il est nécessaire d'ajouter quelque 8 % de nickel à ce matériau, ceci accroît la résistance à la corrosion. Cette composition est à la base de la qualité AISI 304. La qualité AISI 304 L est une variante bien connue, dont la teneur en carbone est réduite. L'avantage d'une teneur peu élevée en carbone réside dans le fait que le risque de voir se former des carbures de chrome dans des composants soumis à de lourdes charges thermiques est réduit. L'ajout de 8 % de nickel provoque une modification significative de toutes les caractéristiques du matériau. Parmi celles-ci, les plus importantes sont les suivantes:

- des propriétés mécaniques différentes;
- une meilleure conductibilité et une meilleure maniabilité;
- une résistance accrue à de hautes températures;
- une soudabilité accrue;
- des propriétés physiques, telles qu'une conductivité thermique plus faible et une dilatation thermique plus importante;
- pas de magnétisme.

Le champ d'application de cet acier est nettement plus grand que celui de l'acier chromifère en raison de ses propriétés et qualités uniques. Parmi les applications, citons l'industrie laitière, le secteur de la transformation alimentaire ainsi que les structures et canalisations de toute une série de processus chimiques modérés.

Le molybdène renforce la passivité de l'acier inoxydable austénitique, car il améliore le film d'oxyde de chrome. Une teneur en molybdène de 2 % améliore considérablement la résistance à la corrosion, ce qui a donné lieu à la généralisation des types AISI 316(L). Ces types présentent une bonne résistance à la corrosion dans de nombreux processus chimiques et même dans des environnements d'eau de mer dans certaines conditions. Le molybdène a le même effet sur la structure que le chrome.

Toepassingsgebieden van diverse roestvaststaaltypen

Technische bijlagen

Technical Data

Technischen Daten

Données techniques

Type AISI 304:

Dit betreft de meest voorkomende Cr-Ni 18/8 kwaliteit die veelvuldig wordt toegepast in de voedsel- en farmaceutische industrie als transportpijpen en opslagunits. Voorts worden er allerlei apparaten van vervaardigd t.b.v. de bierbrouwerijen, margarinefabrieken en slachterijen. Ook vindt de legering toepassing in de papierfabricage als leidingwerk en verdampingsbuissystemen. In de chemische industrie wordt de legering gebruikt in apparaten t.b.v. bijv. salpeterzuur- en nitratenbereiding alsmede kunstmesten op nitraatbasis, explosieven etc.

Type AISI 304L:

Deze legering wordt voornamelijk toegepast in de chemische-, voedsel- en farmaceutische industrie e.d. als reactievaten, opslagtanks en andere apparaten. Ruwweg kan men aan dezelfde toepassingen denken als de kwaliteit AISI 304. Roestvaststaal AISI 304L wordt vooral daar toegepast waar het metaal wordt vervormd of langdurig thermisch wordt belast. Vooral bij het verhitten tot temperaturen tussen 500-900°C is het aan te bevelen dit materiaal te gebruiken.

Type AISI 316:

Vanwege het toevoegen van molybdeen is deze legering zuurbestendig geworden en dat ook in de laszone. Het wordt veelal toegepast in de cellulosefabricage zoals kookpotten, leidingwerk, bleek-units etc. Ook vindt deze legering zijn weg naar de chemische industrie zoals in reactorvaten, leidingwerk en apparaten voor de productie van allerlei zouten, organische- en anorganische zuren. Voorts wordt het gebruikt als tanks t.b.v. zuren en oplosmiddelen. Tevens vindt het zijn weg als materiaal voor verhitingsbuizen in de stoomtechnologie.

Type AISI 316L:

Dit betreft een laag-koolstofuitvoering van het voorgaande materiaal. Het toepassingsgebied komt in grote lijnen overeen met het type AISI 316. Ook hier geldt dat het wordt toegepast vooral op die plaatsen "waar het materiaal wordt blootgesteld aan langdurige thermische belasting; vooral tussen temperaturen van 500-900°C."

Type AISI 321:

Dit betreft een variatie van de AISI 304 kwaliteit die met titaan gestabiliseerd is met als doel de neiging tot chroomcarbidevorming tegen te gaan. Vooral bij het toepassen boven de 300°C komt deze legering in aanmerking hoewel type AISI 304L qua corrosieprestatie niets onder zal doen. De toepassingsgebieden zijn dezelfde als die van type AISI 304/304L.

Duplex roestvaststaal UNS S 31803 (Werkstoffnr. 1.4462):

Duplex roestvaststaal bestaat uit een tweefase structuur t.w. ferriet en austeniet. Het ferriet in de structuur zorgt voor uitstekende mechanische eigenschappen zoals een hoge treksterkte en rekgrens, terwijl het austeniet voor een goede kerftaaiheid zorgt bij lage temperatuur. De chemische samenstelling staat borg voor een goede corrosiebestendigheid met name tegen putcorrosie en spanningscorrosie. De belangrijkste legeringselementen zijn chroom, nikkel, molybdeen en stikstof.

Duplex roestvaststaal wordt o.a. toegepast bij de olie- en gasproductie en in de chemische en petrochemische industrie.

Door de goede mechanische eigenschappen van duplex roestvaststaal ten opzichte van de austenitische roestvast-staalsoorten kan vaak dunner geconstrueerd worden waardoor een gewichtsbesparing ontstaat.

Application areas of different types of stainless steel

AISI 304:

This is the most common Cr-Ni 18/8 quality and it is used widely in the food processing and pharmaceutical industries for piping and storage units. It is also used to manufacture all kinds of equipment for the brewing industry, margarine factories and abattoirs.

This alloy is also used in paper making for piping and evaporator tubing systems.

The alloy is used in the chemical industry to manufacture equipment for processes making such products as nitric acid and nitrates, nitrate fertilizers and explosives.

AISI 304L:

This alloy is used primarily in the chemical, food processing, pharmaceutical and other industries for reactor vessels, storage tanks and other equipment. In broad terms it is used in the same sorts of applications as AISI 304.

Stainless steel AISI 304L is used primarily in cases where the metal is deformed or subjected to thermal loads over extended periods. It is particularly advisable to use this material where there is heating to temperatures between 500 and 900°C.

AISI 316:

The addition of molybdenum makes this alloy oxygen resistant, even in the welding zone. It is widely used in cellulose manufacturing in, for example, digesters, piping and bleaching units.

This alloy is also found in the chemical industry, where it is used in reactor vessels, piping and equipment for the production of all sorts of salts and organic and inorganic acids. Its applications also include tanks for storing acids and solvents. The material is also used for heater tubes in steam generation technology.

AISI 316L:

This is a low-carbon version of AISI 316, and its area of application is largely the same. As is the case for AISI 316, it is used primarily in places 'where the material is exposed to prolonged thermal loads, particularly at temperatures between 500 and 900°C'.

AISI 321:

This is a variation of the AISI 304 grade that has been stabilized with titanium in order to suppress the tendency to form chromium carbides. This alloy is a candidate primarily for applications above 300°C, although AISI 304L is its equal in terms of corrosion performance. The application areas are the same as those of AISI 304/304L.

Duplex stainless steel UNS S 31803 (Material no. 1.4462):

Duplex stainless steel is made up of a two-phase structure of ferrite and austenite. The ferrite gives the structure excellent mechanical properties, such as a high ultimate tensile strength and strain at failure, while the austenite provides good notch toughness at low temperatures. The chemical composition guarantees good corrosion performance, particularly with regard to pitting and stress corrosion. The major alloying elements are chromium, nickel, molybdenum and nitrogen.

Duplex stainless steel is used in oil and gas production, the chemical and petrochemical industries and elsewhere.

The specific mechanical properties of duplex stainless steel, as compared with austenitic stainless steel types, mean that designs can be made with thinner walls, thus saving weight.

Anwendungsbereiche verschiedener nichtrostender Stahlsorten

Technische bijlagen

Technical Data

Technischen Daten

Données techniques

Typ AISI 304:

Dabei handelt es sich um die am häufigsten vorkommende Cr-Ni-18/8-Qualität, die in der Nahrungsmittelindustrie und pharmazeutischen Industrie häufig bei Förderleitungen und Lagereinheiten verwendet wird. Außerdem dient dieser Typ zur Herstellung verschiedener Geräte für Bierbrauereien, Margarinefabriken und Schlachtereien.

Zudem wird die Legierung für Rohrleitungen und Verdampfungsrohrsysteme bei der Papierherstellung eingesetzt.

Die chemische Industrie hat in Geräten für die Herstellung von Salpetersäure, Nitraten, Kunstdünger auf Nitratbasis, Sprengstoff usw. Verwendung für die Legierung.

Typ AISI 304L:

Diese Legierung wird hauptsächlich in der chemischen und pharmazeutischen Industrie sowie in der Nahrungsmittelindustrie und ähnlichen Branchen bei Reaktionsgefäßen, Lagerbehältern und anderen Geräten verwendet. Im Prinzip ist an die gleichen Anwendungen zu denken wie bei der Qualität AISI 304.

Nichtrostender Stahl des Typs AISI 304L wird vor allem dann eingesetzt, wenn das Metall verformt wird oder längere Zeit einer thermischen Belastung ausgesetzt ist. Vor allem beim Erhitzen auf Temperaturen zwischen 500-900 °C ist die Verwendung dieses Materials zu empfehlen.

Typ AISI 316:

Aufgrund des Molybdänzusatzes ist diese Legierung säurebeständig geworden und zwar auch in der Schweißzone. Anwendungsbereich ist vielfach die Zelluloseherstellung, d.h. es ist u.a. in Kochern, Rohrleitungen und Bleichanlagen zu finden.

Auch in der chemischen Industrie wird diese Legierung verwendet, z.B. in Reaktionsgefäßen, Rohrleitungen und Geräten für die Herstellung verschiedener Salze sowie organischer und anorganischer Säuren. Darüber hinaus wird sie bei Säure- und Lösungsmittelbehältern benutzt, und dieser Typ dient als Material für Heizrohre in der Dampftechnologie.

Typ AISI 316L:

Dabei handelt es sich um eine Version des vorangehenden Typs mit niedrigem Kohlenstoffgehalt. Der Anwendungsbereich stimmt im wesentlichen mit dem von AISI 316 überein. Auch hier gilt, daß das Material vor allem dort zum Einsatz kommt, "wo es längere Zeit einer thermischen Belastung ausgesetzt ist, insbesondere bei Temperaturen von 500-900 °C."

Typ AISI 321:

Dabei handelt es sich um eine Variante der Qualität AISI 304, die mit Titan stabilisiert wurde, um dadurch der Gefahr einer Chromkarbidbildung entgegenzuwirken. Vor allem bei der Anwendung über 300 °C kommt diese Legierung in Frage, obwohl der Typ AISI 304L hinsichtlich der Korrosionsleistung gleichwertig ist. Die Anwendungsbereiche entsprechen denen des Typs AISI 304/304L.

Nichtrostender Duplexstahl UNS S 31803 (Werkstoffnr. 1.4462):

Nichtrostender Duplexstahl besteht aus einer Zweiphasenstruktur, in diesem Fall Ferrit und Austenit. Ferrit in der Struktur sorgt für hervorragende mechanische Eigenschaften, wie eine hohe Zugfestigkeit und Dehnungsgrenze, während Austenit bei niedriger Temperatur eine gute Kerbschlagzähigkeit bewirkt. Die chemische Zusammensetzung gewährleistet eine gute Korrosionsbeständigkeit, insbesondere gegen Grübchen- und Spannungskorrosion.

Die wichtigsten Legierungselemente sind Chrom, Nickel, Molybdän und Stickstoff.

Nichtrostender Duplexstahl wird u.a. bei der Öl- und Gasproduktion sowie in der chemischen und petrochemischen Industrie verwendet.

Aufgrund der guten mechanischen Eigenschaften des nichtrostenden Duplexstahls im Vergleich zu den austenitischen nichtrostenden Stahlsorten sind häufig dünnere Konstruktionen möglich.

Champs d'application des différents types d'acier inoxydable

AISI 304:

Il s'agit de la qualité la plus courante de Cr-Ni 18/8. Elle est beaucoup utilisée dans le secteur de la transformation alimentaire et dans l'industrie pharmaceutique dans le cadre des circuits et des unités de stockage. Elle est également largement répandue dans le secteur de la fabrication d'équipements de tout type dans les brasseries, les usines de margarine et les abattoirs.

Cet acier est par ailleurs utilisé dans l'industrie du papier, pour les circuits de canalisations et d'évaporation ainsi que dans l'industrie chimique, pour les équipements de fabrication de produits tels que l'acide nitrique, les nitrates, les engrais à base de nitrate et les explosifs.

AISI 304L:

Cet acier est essentiellement utilisé dans l'industrie chimique et pharmaceutique, dans le secteur de la transformation alimentaire et autre pour la fabrication des cuves de réaction, des réservoirs de stockage et d'autres équipements. Ses champs d'application sont similaires à ceux de l'AISI 304.

L'acier inoxydable AISI 304 L est utilisé principalement dans le cas où le métal est déformé ou soumis à des charges thermiques pendant des périodes prolongées. Il est particulièrement conseillé d'utiliser ce matériau lorsque les températures sont comprises entre 500 et 900°C.

AISI 316:

L'ajout de molybdène rend cet acier résistant à l'acidité, même dans la zone de soudage. Ce matériau est largement utilisé dans la fabrication de cellulose, notamment dans les digesteurs, les circuits et les unités de blanchiment.

Il est également employé dans l'industrie chimique, pour les cuves de réaction, les circuits et les équipements de fabrication d'un grand nombre de sels et d'acides organiques ou non. Parmi ses applications, citons les réservoirs de stockage d'acides et de solvants. Ce matériau est également utilisé dans les tubes de chauffage dans les applications de la technologie de génération de vapeur.

AISI 316L:

Il s'agit d'une version à faible teneur en carbone de l'AISI 316. Son champ d'application est similaire. A l'instar de l'AISI 316, il est utilisé principalement dans le cas où le métal est soumis à des charges thermiques pendant des périodes prolongées. Il est particulièrement conseillé d'utiliser ce matériau lorsque les températures sont comprises entre 500 et 900°C.

AISI 321:

Il s'agit d'une variante de la qualité AISI 304 qui a été stabilisée avec du titane afin de supprimer la tendance à la formation de carbures de chrome. Cet acier est idéal pour des applications soumises à des températures supérieures à 300°C, bien que l'AISI 304 L soit similaire en termes de performance en matière de corrosion. Les applications sont identiques à celles de l'AISI 304/304L.

Acier inoxydable Duplex UNS S 31803 (Matériau n° 1.4462):

L'acier inoxydable Duplex est constitué d'une structure double de ferrite et d'austénite. La ferrite donne à sa structure d'excellentes propriétés mécaniques, un niveau élevé de résistance à la traction et de déformation à la rupture. Sa nature austénitique offre une bonne résistance à l'effet d'entaille à basse température. Sa composition chimique garantit une bonne résistance à la corrosion, en particulier par piqûres et sous tension. Les principaux éléments qui entrent dans sa composition sont le chrome, le nickel, le molybdène et l'azote.

L'acier inoxydable Duplex est utilisé dans le secteur du pétrole et du gaz ainsi que dans l'industrie chimique et pétrochimique.

Les propriétés mécaniques spécifiques de l'acier permettent de concevoir des parois plus fines, par comparaison aux types d'acier inoxydable austénitique, et donc de réduire le poids.

Corrosie is een ongewenste elektrochemische aantasting van een metaal door een agressief medium. We kunnen spreken van een algehele of lokale aantasting van het roestvaststaal. De meeste corrosievormen die voor kunnen komen bij roestvaststaal zijn:

- algemene corrosie
- interkristallijne corrosie
- knife-line attack
- spanningscorrosie
- putcorrosie
- spleetcorrosie
- lasbederf
- besmettingscorrosie
- biologische corrosie

In het kort komen deze corrosievormen op het volgende neer:

Algemene corrosie

Dit is een vorm van corrosie die het oppervlak van het roestvaststaal vrijwel gelijkmatig aantast waardoor de materiaaldikte afneemt. Algemene corrosie, dat ook wel oppervlaktecorrosie wordt genoemd, is vrij ongevaarlijk omdat de levensduur te voorspellen is.

Interkristallijne corrosie

Roestvast-staalsoorten bevatten in leveringstoestand een hoeveelheid koolstof die meestal voor het grootste gedeelte in de austenietstructuur is opgelost. Door verhitting tussen 450 en 850°C kan deze koolstof zich met chroom verbinden tot carbiden die zich in en op de korrelgrenzen gaan uitscheiden. Op deze wijze wordt het chroom aan de matrix onttrokken die daardoor plaatselijk armer aan chroom wordt. Het chroomgehalte kan zelfs lokaal onder de 12% dalen waardoor het roestvaststaal op die plaatsen zijn passiviteit verliest met interkristallijne corrosie als gevolg.

Knife-line attack

Deze vorm van corrosie kan alleen maar voorkomen bij titaan gestabiliseerd roestvaststaal zoals bijvoorbeeld bij AISI 316Ti. De oorzaak moet gevonden worden doordat titaan tijdens het lassen verdampt en verbrandt. Zelfs titaancarbidene kunnen bij de hoge temperatuur uiteenvallen waardoor het titaan ook verdwijnt door oxidatie. Het gevolg is dat het koolstof dan een verbinding aangaat met chroom waardoor net naast de las het materiaal zijn passiviteit verliest met hevige messcherpe corrosie tot gevolg. Om deze gevreesde corrosie te vermijden kan men het beste het type AISI 316L gebruiken dat geheel ongevoelig is voor knife-line attack.

Spanningscorrosie

Deze vorm van corrosie, die ook wel spanningsscheurcorrosie wordt genoemd, treedt vooral op na het koudvervormen waardoor spanningen in het materiaal achterblijven. E.e.a. wordt enorm versterkt door de invloed van halogeen houdende media zoals chloor, fluor, jodium en broom. Bij aantasting van bijvoorbeeld chloriden treden scheuren op die transkristallijn zijn omdat de scheurvorming niet langs doch dwars door de kristallen heenlopen. De hoofdscheurrichting staat bij deze corrosievorm steeds loodrecht op de spanningsrichting. In het algemeen treedt deze gevaarlijke corrosievorm pas op boven de 50° C. Om spanningscorrosie te voorkomen moet men zo spanningsarm mogelijk construeren en het materiaal zo min mogelijk koudvervormen. Indien men hier niet onderuit kan komen, kan men het materiaal voor het in gebruik nemen spanningsarm gloeien op 900°C. Ook geldt dat des te gladder het oppervlak des te geringer de kans op spanningscorrosie is omdat veelal de corrosie begint op oppervlakte-imperfecties zoals kleine scheurtjes of inkepingen.

Putcorrosie

Putvormige corrosie is ook een gevaarlijke vorm van corrosie omdat op kleine plaatsen putten ontstaan die snel dieper kunnen worden vanwege het anodisch gedrag met als gevolg dat het materiaal zelfs geperforeerd kan raken. Vaak begint deze corrosievorm onder een plaatselijk defect in de oxidehuid doch ook onder vuilafzettingen, verfresten, slakresten, slibaanzettingen e.d. De beste remedie is om het materiaal na een bewerking

goed te beitsen en te passiveren. Tijdens het gebruik is het van groot belang dat roestvaststaal schoon wordt gehouden waardoor men kan stellen dat roestvaststaal niet onderhoudsvrij is zoals vaak wordt gedacht.

Spleetcorrosie

Wanneer twee oppervlakken van roestvaststaal in een vloeistof tegen elkaar liggen of wanneer een niet-metallisch voorwerp het staal geheel of gedeeltelijk bedekt, ontstaat er een spleet waarin de vloeistof maar weinig uitwisseling heeft met de zuurstof in de vloeistof daarbuiten. In zulke gevallen treedt vaak ernstige zogenaamde spleetcorrosie op. Voorbeelden vinden we bij pakkingen tussen flenzen, de pijp en pijpplaatverbinding e.d. De oorzaak van spleetcorrosie is dat de zuurstofconcentratie in de spleet lager is dan daarbuiten waardoor de zuurgraad wordt verhoogd met aantasting als gevolg. De beste remedie is het voorkomen van spleten en dit is dus een kwestie van juist construeren.

Lasbederf

Lasbederf is eigenlijk een vorm van interkristallijne corrosie die ontstaan kan in het sensitieve gebied van roestvast-staalsoorten die een relatief hoog koolstofgehalte hebben. Deze vorm van corrosie treedt meestal op tussen 5 en 15 mm van de las bij grotere wanddiktes. De oorzaak is dat men in dit gebied uitscheidingen kan krijgen van chroomcarbiden die weer aanleiding geven voor corrosie zoals beschreven onder het hoofd 'interkristallijne corrosie'. Men kan dit voorkomen door een lage koolstofversie te gebruiken indien men met grote wanddiktes moet werken.

Besmettingscorrosie

Besmettingscorrosie is eigenlijk een variant op putcorrosie omdat vreemde metaaldeeltjes op de een of andere wijze op het roestvast-staaloppervlak zijn gekomen. Op deze wijze ontstaat een potentiaalverschil en meestal een gebrek aan zuurstof onder dit deeltje. Het meest bekende voorbeeld is de besmetting van ijzeren deeltjes die door slijpgereedschappen op het oppervlakte van het roestvaststaal 'gebombardeerd' worden. Het ijzerdeeltje gaat onder invloed van vocht heel snel in oplossing met een bruine vlek als gevolg. Om deze vorm van corrosie te vermijden dient men het verwerken van roestvaststaal gescheiden te houden van koolstofstaal. Ook moet men de juiste gereedschappen gebruiken en in geval van twijfel dient men de oppervlakten te beitsen en te passiveren.

Biologische corrosie

Biologische corrosie ontstaat door micro-organismen die aan het afsterven zijn. Tijdens dit afsterven is zuurstof nodig om deze organische stoffen om te zetten in koolstof en waterstof waardoor verschillen ontstaan in het zuurstofgehalte met mogelijk biologische corrosie als gevolg. Om deze vorm van corrosie te bestrijden dient men altijd zogenaamde dode hoeken te vermijden en moet men de systemen goed schoonhouden.

Corrosion is the unwanted electrochemical attack of a metal by a corrosive medium. Stainless steel can be subject to general or local attack. The most common forms of corrosion that can occur with stainless steel are:

- general corrosion
- intergranular corrosion
- knife-line attack
- stress corrosion
- pitting
- crevice corrosion
- weld decay
- contamination
- biological corrosion

These types of corrosion are described briefly below.

General corrosion

This is a type of corrosion where the surface of the stainless steel is subjected to fairly uniform attack, as a result of which the thickness of the material decreases. General corrosion, which is also referred to as surface corrosion, is not very dangerous because the lifetime can be predicted.

Intergranular corrosion

Stainless steels, as delivered, contain a quantity of carbon, most of which is dissolved in the austenitic structure. When heated to between 450 and 850°C, this carbon can combine with chromium to form carbides, which precipitate at the grain boundaries. This removes chromium from the matrix, and as a consequence this creates a local deficiency in dissolved chromium. The chromium content can even drop below 12% locally, as a result of which the stainless steel loses its passivity in these areas and intergranular corrosion ensues.

Knife-line attack

This form of corrosion can only occur in titanium-stabilized stainless steel, for example AISI 316Ti. The cause has to be sought in the fact that titanium evaporates and combusts during welding. Even titanium carbides can decompose at high temperature, as a result of which titanium disappears through oxidation. The consequence is that the carbon then combines with Cr, and the material immediately adjacent to the weld loses its passivity, and intense knife-line attack follows. The best way to avoid this dreaded form of corrosion is to use AISI 316L, which is totally insensitive to knife-line attack.

Stress corrosion

This type of corrosion, also known as stress corrosion cracking, occurs primarily after cold forming, which leaves behind stresses in the material. This type of corrosion is amplified to a tremendous extent by media containing halogens, such as chlorine, fluorine, iodine and bromine. In the case of attack by chlorides, for example, transgranular cracking occurs, in other words cracks that go across grains rather than around them. In this type of corrosion the main direction of cracks is always perpendicular to the stress direction. Generally speaking this dangerous type of corrosion only occurs above 50°C. Stress corrosion can be prevented by designing and manufacturing in such a way that stress is minimized and by cold working the material as little as possible. If this is unavoidable, the material can be annealed at 900°C in order to relieve stresses before it is used. Here too, the smoother the surface, the smaller the chance of stress corrosion because the corrosion usually starts at surface defects, such as tiny cracks or nicks.

Pitting

Pitting is a dangerous type of corrosion because it leads to the creation of very local pits that can rapidly become deeper because of anodic attack, with the result that the material can even become perforated. This form of corrosion often starts underneath a local defect in the oxide film, or

under fouling deposits, paint residues, slag residues, sludge deposits etc. The best remedy is to pickle and passivate the material after it has been worked. It is very important that the stainless steel is kept clean during use. This means that one cannot assert that stainless steel is maintenance free, as is often assumed.

Crevice corrosion

If two stainless steel surfaces are next to each other in a liquid or if a non-metallic object covers the steel completely or partially, a crevice is created. There is little or no replenishment of the oxygen in the liquid in the crevice by the oxygen in the liquid outside the crevice. Crevice corrosion occurs in such circumstances. We find examples of this in gaskets between flanges, the connection between tube and tube sheet etc. Crevice corrosion is caused because the oxygen concentration in the crevice is lower than outside it, as a result of which acidity increases and attack takes place. The best remedy is to avoid crevices, and so it is a matter of good design practice.

Weld decay

Weld decay is actually a form of intergranular corrosion that can occur in the sensitive area of stainless steels that have a relatively high carbon content. This type of corrosion usually occurs between 5 and 15 mm from the weld at larger wall thicknesses. The reason is that chromium carbide precipitates can occur in this area, which cause corrosion as described above under 'intergranular corrosion'. This type of corrosion can be prevented by using a low carbon content version if it is necessary to work with large wall thicknesses.

Contamination

Contamination corrosion is actually a type of pitting caused through foreign metal particles that arrive one way or another on the surface of the stainless steel. This creates a potential difference and usually an oxygen deficiency underneath such a particle. The best known example is contamination by iron particles that are 'shot' onto the surface of the stainless steel by grinders. Moisture soon dissolves the iron particle, to leave a brown spot. The way to avoid this type of corrosion is to separate the working of stainless steel from carbon steel. It is also important to use the right sort of tools, and in the event of doubt the surfaces should be pickled and passivated.

Biological corrosion

Biological corrosion is caused by micro-organisms that are dying off. During this process oxygen is necessary to convert these organic substances to carbon and hydrogen. This creates differences in oxygen concentration, with possible biological corrosion as a consequence. This type of corrosion can be avoided by always avoiding dead corners and by keeping systems clean.

Korrosion ist eine unerwünschte elektrochemische Zersetzung eines Metalls durch ein aggressives Medium. Nichtrostender Stahl kann einer allgemeinen oder lokalen Form der Zersetzung ausgesetzt sein. Die häufigsten, bei nichtrostendem Stahl vorkommenden Korrosionsformen sind:

- allgemeine Korrosion
- interkristalline Korrosion
- Messerschnittkorrosion
- Spannungskorrosion
- Grübchenkorrosion (Lochfraß)
- Spaltkorrosion
- Schweißkorrosion
- Kontaktkorrosion
- Mikrobiologische Korrosion

Diese Korrosionsformen werden im folgenden kurz erläutert.

Allgemeine Korrosion

Dies ist eine Korrosionsform, bei der die Oberfläche nichtrostenden Stahls ziemlich gleichmäßig zersetzt wird, was zu einer Abnahme der Materialdicke führt. Allgemeine Korrosion, die auch Oberflächenkorrosion genannt wird, ist eigentlich ungefährlich, da die Lebensdauer vorherzusagen ist.

Interkristalline Korrosion

Nichtrostende Stahlsorten enthalten bei der Lieferung eine gewisse Menge an Kohlenstoff, der in den meisten Fällen zum größten Teil in der Austenitstruktur gelöst ist. Durch Erhitzen auf 450 bis 850 °C kann sich dieser Kohlenstoff mit Chrom zu Karbiden verbinden, die sich in und auf den Korngrenzen abscheiden. Auf diese Weise wird der Matrix Chrom entzogen, die somit lokal Chrom einbüßt. An bestimmten Stellen kann der Chromgehalt sogar unter 12% sinken, wodurch der nichtrostende Stahl dort seine Passivität verliert. Die Folge ist interkristalline Korrosion.

Messerschnittkorrosion

Diese Korrosionsform kann nur bei durch Titan stabilisiertem nichtrostendem Stahl auftreten, etwa bei AISI 316Ti. Die Ursache ist darin zu suchen, daß Titan während des Schweißens verdampft und verbrennt. Selbst Titankarbide können bei der hohen Temperatur zerfallen, so daß Titan auch durch Oxidation verschwindet. Die Folge ist, daß Kohlenstoff dann eine Verbindung mit Chrom eingeht, wodurch das Material direkt neben der Schweißnaht seine Passivität verliert. Dadurch entsteht eine starke, messerscharfe Korrosion. Um diese gefürchtete Form der Korrosion zu verhindern, verwendet man am besten den Typ AISI 316L, der völlig unempfindlich ist gegenüber dem "Knife-line attack".

Spannungskorrosion

Diese Korrosionsform, die auch Spannungsrißkorrosion genannt wird, tritt vor allem nach dem Kaltverformen auf, wobei Spannungen im Material zurückbleiben. Sie wird enorm verstärkt durch den Einfluß halogenhaltiger Medien, wie Chlor, Fluor, Jod und Brom. Sorgen beispielsweise Chloride für den Zerfall, treten transkristalline Risse auf, da die Rißbildung nicht längs, sondern quer durch die Kristalle verläuft. Die Hauptrißrichtung befindet sich bei dieser Korrosionsform immer lotrecht zu der Spannungsrichtung. Im allgemeinen tritt diese gefährliche Korrosionsform erst bei über 50 °C auf. Um Spannungskorrosion zu verhindern, sollte möglichst spannungsarm konstruiert und das Material möglichst nicht kaltverformt werden. Ist ein solches Vorgehen nicht möglich, kann das Material vor der Benutzung durch Spannungsarmglühen bei 900 °C behandelt werden. Außerdem gilt, je glatter die Oberfläche, desto geringer das Risiko einer Spannungskorrosion, da Korrosion häufig dort auftritt, wo Oberflächenunebenheiten, wie kleine Risse oder Einkerbungen, zu finden sind.

Grübchenkorrosion

Grübchenförmige Korrosion ist auch eine gefährliche Korrosionsform, da an kleinen Stellen Grübchen entstehen, die aufgrund des anodischen Verhaltens schnell tiefer werden können. Das kann letztendlich zur Perforation des Materials führen. Häufig beginnt diese Korrosionsform unter

einer lokalen Beschädigung in der Oxidhaut oder unter Schmutzablagerungen, Farbresten, Schlackeresten, Schlammablagerungen u.ä. Die beste Methode, derartiges zu verhindern, ist das Beizen und Passivieren des Materials nach einer Bearbeitung. Während der Verwendung sollte nichtrostender Stahl unbedingt saubergehalten werden. Somit kann man durchaus behaupten, daß nichtrostender Stahl - anders als häufig angenommen wird - einer gewissen Pflegebehandlung bedarf.

Spaltkorrosion

Wenn zwei Oberflächen aus nichtrostendem Stahl in einer Flüssigkeit nebeneinanderliegen oder wenn ein nicht-metallisches Objekt den Stahl ganz oder teilweise bedeckt, entsteht ein Riß, wobei kaum Austausch zwischen der Flüssigkeit im Riß mit dem Sauerstoff in der Flüssigkeit außerhalb des Risses stattfindet. In solchen Fällen tritt häufig eine starke Rißkorrosion auf. Beispiele dafür sind etwa Dichtungen zwischen Flanschen, Rohr-Platte-Verbindungen usw. Rißkorrosion wird verursacht, wenn die Sauerstoffkonzentration im Riß geringer ist als außerhalb des Risses, wodurch der Säuregrad erhöht wird und eine Zersetzung eintritt. Um diese Korrosionsform zu verhindern, sollten Risse vermieden werden, d.h. es geht darum, korrekt zu konstruieren.

Schweißkorrosion

Schweißkorrosion ist eigentlich eine Form der interkristallinen Korrosion, die in dem empfindlichen Bereich nichtrostender Stahlsorten mit relativ hohem Kohlenstoffgehalt entstehen kann. Diese Korrosionsform tritt meistens 5 bis 15 mm von der Schweißnaht bei größeren Wandstärken auf. Die Ursache sind Abscheidungen von Chromkarbiden in diesem Bereich, die eine Korrosion bewirken können, wie unter der Unterschrift "interkristalline Korrosion" beschrieben wurde. Dies kann verhindert werden, indem man einen Typ mit niedrigem Kohlenstoffgehalt verwendet, wenn mit großen Wandstärken zu arbeiten ist.

Kontaktkorrosion

Kontaktkorrosion ist eigentlich eine Form der Grübchenkorrosion, weil auf irgendeine Weise fremde Metallteilchen auf die Oberfläche aus nichtrostendem Stahl gelangt sind. Dadurch entsteht ein Potentialunterschied und meistens auch Sauerstoffmangel unter diesen Teilchen. Das wohl bekannteste Beispiel ist die Kontamination von Eisenteilchen, die durch Schleifwerkzeuge auf die Oberfläche des nichtrostenden Stahls "geschossen" werden. Unter Einfluß von Feuchtigkeit löst sich das Eisenteilchen schnell auf und hinterläßt einen braunen Fleck. Um diese Korrosionsform zu verhindern, sollte bei der Verarbeitung von rostfreiem Stahl kein Kohlenstoffstahl zum Einsatz kommen. Außerdem ist das richtige Werkzeug zu benutzen, und im Zweifelsfall sollten die Oberflächen gebeizt und passiviert werden.

Mikrobiologische Korrosion

Mikrobiologische Korrosion entsteht durch Mikro-organismen, die sich im Zustand des Absterbens befinden. Für diesen Vorgang wird Sauerstoff benötigt, um diese organischen Stoffe in Kohlenstoff und Wasserstoff zu verwandeln. Dadurch entstehen Unterschiede beim Sauerstoffgehalt, so daß eine eventuelle mikrobiologische Korrosion die Folge sein kann. Diese Korrosionsform ist zu vermeiden, wenn sogenannte tote Winkel vermieden und die Systeme saubergehalten werden.

Corrosion de l'acier inoxydable

La corrosion désigne l'attaque électrochimique d'un métal par un agent corrosif. L'acier inoxydable peut être victime de corrosion générale ou locale. Les formes les plus courantes de la corrosion de l'acier inoxydable sont les suivantes:

- la corrosion générale,
- la corrosion intergranulaire,
- la corrosion en lame de couteau,
- la corrosion sous tension,
- la corrosion par piqûres,
- la corrosion par fissure,
- la désintégration de la soudure,
- la contamination,
- la corrosion biologique.

Ces types de corrosion sont brièvement décrits ci-dessous.

Corrosion générale

Dans ce type de corrosion, la surface de l'acier inoxydable est soumise à une attaque pratiquement uniforme, ce qui provoque une réduction de l'épaisseur du matériau. La corrosion générale, également appelée corrosion de surface, n'est pas très dangereuse étant donné que l'on peut définir la durée de vie du matériau.

Corrosion intergranulaire

Les aciers inoxydables contiennent une certaine quantité de carbone, dont la majeure partie est dissoute dans la structure austénitique. A des températures comprises entre 450 et 8850°C, ce carbone peut se combiner au chrome pour former des carbures qui se précipitent au niveau des joints de grain. Ce processus provoque l'élimination du chrome de la matrice, et donc une déficience locale en chrome dissout. La teneur en chrome peut même chuter localement sous les 12 %, amenant ainsi l'acier inoxydable à perdre sa passivité dans ces zones et la corrosion intergranulaire à s'installer.

Corrosion en lame de couteau

Cette forme de corrosion ne se produit que sur l'acier inoxydable stabilisé au titane, l'AISI 316Ti, par exemple. Elle est due au fait que le titane s'évapore et se consume pendant le soudage. Même les carbures de titane peuvent se décomposer à haute température, ce qui provoque l'élimination du titane par oxydation. Le carbone se combine alors au chrome, ce qui provoque une perte de la passivité du matériau situé à proximité immédiate de la soudure et, par là, une corrosion en lame de couteau. Le meilleur moyen pour éviter cette forme dangereuse de corrosion est d'utiliser de l'acier AISI 316 L qui est totalement invulnérable à cette forme de corrosion.

Corrosion sous tension

Ce type de corrosion, également connu sous le nom de « fissuration par corrosion sous contrainte » se produit principalement après le formage à froid qui génère des contraintes dans le matériau. Cette forme de corrosion est considérablement amplifiée par les milieux contenant des halogènes, tels que le chlore, l'iode et le brome. Dans le cas d'attaques dues au chlore, la fissuration transgranulaire se produit, c'est-à-dire que les fissures se manifestent entre les grains et non autour d'eux. La fissuration s'opère systématiquement à la perpendiculaire du sens des contraintes. Cette forme dangereuse de corrosion ne se produit qu'à des températures supérieures à 50°C. L'adoption de modes de conception et de fabrication spécifiques peut permettre d'éviter cette forme dangereuse de corrosion : il convient de minimiser les contraintes et de réduire au minimum le formage à froid du matériau. S'il est impossible de pratiquer de la sorte, le matériau peut être recuit à 900°C afin d'en éliminer les contraintes avant son utilisation. Dans ce cas également, plus la surface est fine, moins il y a de risques de voir la corrosion sous tension se produire, car cette forme de corrosion se développe au niveau des défauts de la surface, tels que des fissures ou des entailles peu importantes.

Corrosion par piqûres

Cette forme de corrosion est dangereuse, car elle conduit à la création de petites piqûres qui peuvent rapidement s'approfondir sous l'effet d'une attaque anodisée. Le matériau peut même être perforé dans des cas extrêmes. Cette forme de corrosion se développe souvent sous un défaut localisée dans le film d'oxyde, un encrassement, des résidus de peinture, de laitier, etc. Le meilleur remède à cette forme de corrosion consiste à passer le matériau dans une solution aqueuse de sel pour le passiver une fois travaillé. Il est très important de veiller à la propreté du matériau pendant son utilisation. Il est donc faux de croire que l'acier inoxydable ne demande pas d'entretien, contrairement à ce que l'on entend souvent.

Corrosion par fissure

Si deux surfaces d'acier inoxydable sont proches l'une de l'autre dans un liquide ou si un objet non métallique recouvre le métal partiellement ou totalement, une fissure se crée. L'oxygène présent dans le liquide n'est renouvelé pas dans la fissure par l'oxygène présent dans le liquide à l'extérieur de la fissure. Cette forme de corrosion se produit dans ces circonstances. Elle se manifeste dans les joints entre flasques, dans les raccords entre tubes et plaques tubulaires, etc. La corrosion par fissure est provoquée par le fait que la concentration d'oxygène à l'intérieur de la fissure est supérieure à celle à l'extérieur de la fissure. Dans ce cas, l'acidité augmente et la corrosion se produit. Le meilleur remède est d'éviter les fissures, ce qui demande l'adoption de bonnes pratiques dans le domaine de la conception.

Désintégration de la soudure

La désintégration de la soudure est une forme de corrosion intergranulaire qui se produit dans les zones sensibles de l'acier inoxydable à haute teneur en carbone. Ce type de corrosion se manifeste à une distance comprise entre 5 et 15 mm de la soudure en cas d'épaisseur plus importante des parois. Elle s'explique par la précipitation des carbures de chrome qui peuvent avoir lieu dans ces zones. Le processus est décrit ci-dessus dans la présentation de la corrosion intergranulaire. On peut y remédier en utilisant une qualité d'acier à faible teneur en carbone, quand on travaille avec des épaisseurs de parois importante.

Contamination

La corrosion par contamination se présente sous la forme de piqûres provoquées par des corps étrangers qui entrent en contact avec la surface de l'acier inoxydable. Cela provoque une différence potentielle et, généralement, une déficience en oxygène sous les particules. L'exemple le plus connu est la contamination par des particules de fer qui sont « propulsées » sur la surface de l'acier inoxydable par des rectifieuses. L'humidité dissout rapidement les particules de fer, ce qui laisse un point marron. Le meilleur moyen pour éviter cette forme de corrosion est de séparer les opérations liées à l'acier inoxydable et celles liées à l'acier au carbone. Il est également important d'utiliser les outils prévus à cet effet. En cas de doute, les surfaces doivent être passées dans une solution aqueuse de sel et passivées.

Corrosion biologique

La corrosion biologique est provoquée par des microorganismes qui dépérissent. Au cours de ce processus, l'oxygène est indispensable pour convertir ces substances organiques en carbone et en hydrogène. Cela provoque des différences dans les concentrations d'oxygène, et une éventuelle corrosion biologique. Pour éviter que cette forme de corrosion ne se produise, il convient de ne pas prévoir d'angles inutiles et de veiller à la propreté des systèmes.

Roestvaststaal kan op verschillende manieren worden beproefd en in de regel geven de onderstaande onderzoeken de meest relevante informatie teneinde de prestaties van het betreffende materiaal te kunnen bepalen:

- Mechanische beproevingen (ook wel destructief onderzoek genoemd);
- Technologische beproevingen;
- Metallografisch onderzoek;
- Fysisch onderzoek;
- Analytisch onderzoek;
- Elektrochemisch onderzoek;
- Non-destructief onderzoek.

Het doel van het mechanisch onderzoek is om de grootte van diverse eigenschappen van het metaal vast te stellen. We kunnen daarbij denken aan de rekgrens, de rek, de trekvastheid, de insnoering, de hardheid, de kruipsterkte, de kerfslagwaarde e.d.

Technologische beproevingen zijn in de regel de buigproef, de ringbuigproef, de opdoornproef e.d. die allemaal het doel hebben om de vervormbaarheid van het metaal te bepalen.

Metallografisch onderzoek is erop gericht informatie te krijgen over de microstructuur van het materiaal, de korrelgrootte en de effecten van een warmtebehandeling. Ook wordt dit onderzoek gebruikt voor het macro-onderzoek van de laszone.

Het fysisch onderzoek richt zich op de bepaling van fysische grootheden zoals het warmte- en elektrisch geleidingsvermogen, de specifieke warmte e.d.

M.b.v. het analytisch of chemisch onderzoek kan men de chemische samenstelling van het betreffende metaal bepalen.

Met het elektrochemische onderzoek krijgt men inzicht in het gedrag van het metaal in allerlei corrosieve processen en dat veelal in combinatie met andere metalen.

Een zeer vriendelijke beproevingsmethode is het non-destructieve onderzoek dat namelijk het betreffende metaal niet beschadigt waardoor het in principe ondanks de beproevingen inzetbaar blijft. Men kan dan denken aan het oppervlakteonderzoek (penetrant), de maatcontrole, US-onderzoek om mogelijk inwendige fouten te kunnen vaststellen, wervelstroomonderzoek, materiaalverwisselingsproef (PMI), lekdetectie, röntgenonderzoek, enz.

Testing

Stainless steel can be tested in a number of different ways and generally speaking the types of testing listed below provide the most relevant information for determining the performance of the material concerned.

- Mechanical (also referred to as destructive);
- Technological;
- Metallographic;
- Physical;
- Analytical;
- Electrochemical;
- Non-destructive.

The aim of mechanical testing is to establish the magnitude of different properties of the metal. Examples of these are the elastic limit, the strain, the ultimate tensile strength, the necking, the hardness, the creep strength, the notch toughness etc.

As a rule the technological tests are the bending test, the ring bending test etc., which are all intended to measure the deformability of the metal.

Metallographic examination is intended to obtain information about the microstructure of the material, the grain size and the effects of heat treatment. This type of examination is also used for the macro-investigation of the welding zone.

Physical testing is concerned with determining physical properties such as thermal and electrical conductivity, specific heat etc.

Analytical and chemical tests can be used to determine the chemical composition of the metal concerned.

Electrochemical testing provides information about the behaviour of the metal in all sorts of corrosive processes, usually in combination with other metals.

Non-destructive testing is a very friendly test method that does not damage the metal concerned, which can therefore continue to be used despite the tests. Examples of such tests are surface examination (penetrant), dimensional checks, ultrasonic measurements to identify possible internal flaws, eddy current testing, material interchange test (PMI), dye penetrant test, X-ray examination etc.

Nichtrostender Stahl kann auf verschiedene Art und Weise geprüft werden. In der Regel gehen aus den folgenden Prüfverfahren die wichtigsten Informationen hervor, um die Leistungen des betreffenden Materials bestimmen zu können.

- Mechanische Prüfung (wird auch Zerstörungsprüfung genannt)
- Technologische Prüfung
- Metallographische Prüfung
- Physikalische Prüfung
- Analytische Untersuchung
- Elektrochemische Untersuchung
- Zerstörungsfreie Prüfung

Ziel der mechanischen Prüfung ist die Feststellung der Größenordnung verschiedener Eigenschaften des Metalls. Beispiele sind u.a. Dehnungsgrenze, Dehnung, Zugfestigkeit, Einschnürung, Härte, Kriechfestigkeit und Kerbschlagzähigkeit.

Die technologische Prüfung beinhaltet im allgemeinen die Biegeprüfung, die Ringbiegeprüfung, den Aufdornversuch usw., die allesamt dazu dienen, die Verformbarkeit des Metalls zu bestimmen.

Die metallographische Prüfung soll Informationen über die Mikrostruktur des Materials, die Korngröße und die Einflüsse einer Wärmebehandlung liefern. Zudem dient diese Prüfung zur Makrountersuchung der Schweißzone.

Die physikalische Prüfung ist auf die Bestimmung physikalischer Größen, wie etwa Wärmeleitfähigkeit, elektrische Leitfähigkeit und spezifische Wärme ausgerichtet.

Mittels analytischer oder chemischer Untersuchung läßt sich die chemische Zusammensetzung des betreffenden Metalls bestimmen.

Mittels elektrochemischer Untersuchung erhält man Einsicht in das Verhalten des Metalls bei verschiedenen korrosiven Prozessen, und zwar meistens in Verbindung mit anderen Metallen.

Die zerstörungsfreie Prüfung ist ein sehr objektfreundliches Verfahren, weil das betreffende Metall nämlich nicht beschädigt wird und im Prinzip trotz der Versuche verwendbar bleibt. Beispiele sind u.a. Oberflächenprüfung (penetrant), Maßhaltigkeitsprüfung, Ultraschallprüfung zur Aufspürung möglicher Fehler im Inneren, Wirbelstromprüfung, Materialaustauschversuch (PMI), Leckortung und Röntgenprüfung.

Tests

L'acier inoxydable peut être testé de différentes manières. En général, les tests énumérés ci-dessous permettent de réunir les informations les plus pertinentes concernant la qualité des matériaux testés :

- les tests mécaniques (également appelés « épreuves de rupture »);
- les tests technologiques;
- les tests métallographiques;
- les tests physiques;
- les tests analytiques;
- les tests électrochimiques;
- les tests non destructifs.

Les tests mécaniques ont pour objectif d'établir les différentes propriétés du métal, notamment la limite d'élasticité, la contrainte, la résistance à la traction, la striction, la dureté, la résistance au fluage, la résistance à l'effet d'entaille, etc.

Les tests technologiques renvoient au test de pliage, au test de pliage par retournement, etc. Tous ces tests visent à mesurer la déformabilité du métal.

Les tests métallographiques servent à réunir des informations sur la microstructure du matériau, sur la dimension du grain et sur les effets du traitement thermique. Ce type de test est également utilisé dans le cadre de la macro-étude de la zone de soudage.

Les tests physiques visent à identifier les propriétés physiques, telles que la conductivité thermique et électrique, la chaleur massique, etc.

Les tests analytiques et chimiques sont utilisés pour déterminer la composition chimique du métal étudié.

Les tests électrochimiques permettent de réunir des informations sur le comportement du métal dans toute une série de processus corrosifs, généralement en combinaison avec d'autres métaux.

Les tests non destructifs est une méthode de test qui n'endommage pas le métal étudié. Dès lors, le métal peut continuer à être utilisé malgré les tests. Parmi ceux-ci, citons les essais de surface (liquide d'imprégnation), les contrôles dimensionnels, les mesures ultrasoniques (qui servent à identifier d'éventuelles failles internes), le test par courant de Foucault, le test PMI (« material interchange »), les essais par ressuage, les tests radiographiques, etc.

EN 10204 Soorten keuringsdocumenten
EN 10204 Types of inspection documents
EN 10204 Arten von Prüfbescheinigungen
EN 10204 Types de documents de contrôle

EN 10204 Reference	Designation of the document type			Document content	Document validated by
	English version	German version	French version		
Type 2.1	Declaration of compliance with the order	Werksbescheinigung	Attestation de conformité a la commande	Statement of compliance with the order	The manufacturer
Type 2.2	Test report	Werkzeugnis	Relevé de contrôle	Statement of compliance with the order, with indication of results of non-specific inspection	The manufacturer
Type 3.1	Inspection certificate 3.1	Abnahmeprüfzeugnis 3.1	Certificat de réception 3.1	Statement of compliance with the order, with indication of results of specific inspection	The manufacturer's authorized inspection representative independent of the manufacturing department
Type 3.2	Inspection certificate 3.2	Abnahmeprüfzeugnis 3.2	Certificat de réception 3.2	Statement of compliance with the order, with indication of results of specific inspection	The manufacturer's authorized inspection representative independent of the manufacturing department and either the purchaser's authorized inspection representative or the inspector designated by the official regulations